

Pearl®

MARCHING & CONCERT

2014



Pearl®

MARCHING & CONCERT | 2014

4-5 Experience the Pearl Difference

6-7 A Standard of Excellence

MARCHING PERCUSSION

8-9 Championship CarbonPly

10-11 Championship CarbonCore

12-15 Championship Maple

16-19 Competitor Series

20-23 Championship Pipe

24-25 CX AirFrame Carriers

26-27 MX T-Frame Carriers

28-29 Advanced Marching Hardware

30-31 Accessories

CONCERT PERCUSSION

32-35 Philharmonic Series Drums

36-37 Symphonic Series Drums

38-39 Concert Series Drums

40-41 Educational Kits

42-45 Advanced Concert Hardware

ACCESSORIES & SETS

46-47 Congas, Bongos, Cajons, Timbales

48-49 Concert Accessories

50-51 Drum Sets

52 Color Chart



BLUE DEVILS CONCORD, CA • 15-TIME DCI WORLD CHAMPIONS



RIVERSIDE CITY COLLEGE RIVERSIDE, CA



UNIVERSITY OF CINCINNATI CINCINNATI, OH



UNIVERSITY OF AUBURN AUBURN, AL



UNIVERSITY OF SOUTH CAROLINA COLUMBIA, SC



SPIRIT OF ATLANTA ATLANTA, GA



BROOKWOOD INDEPENDENT BROOKWOOD, AL • 2013 WGI INDEPENDENT A CLASS GOLD MEDALISTS



MUSIC CITY MYSTIQUE NASHVILLE, TN



RHYTHM X COLUMBUS, OH • 2013 WGI INDEPENDENT WORLD CLASS GOLD MEDALISTS



UPPER DARBY HIGH SCHOOL UPPER DARBY, PA • 2013 WGI SCHOLASTIC OPEN GOLD MEDALISTS



UNIVERSITY OF GEORGIA ATHENS, GA



OHIO STATE UNIVERSITY COLUMBUS, OH

For more info, please visit any of our sites listed below:



HALL OF CHAMPIONS

Join the excitement of gameday and experience the **Sound of Saturday!** Featuring collegiate athletic bands from across the country who choose Pearl / Adams for their percussion needs.

www.PearlHallofChampions.com



PEARL RUDIMENTS

Learn the 40 PAS Sanctioned Rudiments with **over 100+ videos** from Legendary Pearl Artists such as Thom Hannum, Scott Johnson, Mike Mangini, and Grant Collins.

www.PearlDrumRudiments.com



PEARL / ADAMS DCI

Complete coverage throughout the Drum Corps International season of your favorite Pearl / Adams drum corps. Photo galleries, lot videos, and more!

www.PearlAdamsDCI.com



PEARL / ADAMS WGI

Featuring coverage of your favorite Pearl / Adams indoor percussion ensembles throughout the WGI season. Featuring videos, pictures, and rehearsal footage of the world's top ensembles!

www.PearlAdamsWGI.com

THE FFX LEGACY



No other snare drum has changed the face of marching competition like the FFX Championship Series. No matter which of our premium shell designs are used, the truly Free-Floating design of the FFX sets the industry standard for dynamic range, sensitivity, and unsurpassed projection.

The FFX Aluminum Edge Ring frame gives you a top bearing edge that can take all of the pressure necessary for today's high tension heads. Without any mounting devices attached, the shell is free to enhance the tonal response, and focus the drum's maximum sensitivity and volume.

All Pearl Marching Shells are made using Pearl's Exclusive SST Superior Shell Technology.



Extreme Strength | Optimal Resonance | Superior Tone

EXPERIENCE THE PEARL DIFFERENCE IN MARCHING PERCUSSION



CarbonPly Snare and Tenor shells features 6 plies of exotic African Mahogany sandwiched between an inner and outer ply of Carbon Fiber. This distinctive combination perfectly balances the warm low frequency of African Mahogany and the exuberant mid to high range tendencies of Carbon Fiber - an aural blend frequently chosen by Pearl's most elite Drum Corps and University Marching Bands.



CarbonCore Snares and Tenors feature a 100% Maple Shell, with an added inner ply of ultra light Carbon Fiber. The added "CarbonCore" material takes these higher-frequency voices to their most expressive limits - clear and articulate at low volumes, crisp and powerful at high volumes. The warmth of tone given by 6 plies of Maple, married with the boosted highs of the CarbonCore creates a brand new maximized Snare and Tenor sound. CarbonCore is the newest Pearl sound on the field, and an instant Championship Sound.



Championship Maple is the industry standard in marching drums due to its range of frequency response and warmth in sound quality. Maple shells have a smooth, even texture that remains durable under a wide range of conditions and accepts a variety of rich lustrous finishes. Maple is the choice of champions- a full, articulate sound chosen by world class Marching Ensembles year after year.



	CARBONPLY SD	CARBONPLY BD	CARBONPLY TD	CARBONCORE SD	CARBONCORE TD
SHELL MATERIAL	African Mahogany*	Maple*	African Mahogany*	Maple**	Maple**
NUMBER OF PLYS	6	6	6	6	6
THICKNESS (mm)	7.5	7.5	7.5	7.5	7.5
R. RING	Yes (Bottom Only)	-	Yes (Top Only)	Yes (Bottom Only)	Yes (Top Only)
BEARING EDGE	45°	45°	Fully Rounded (Top) Flat (Bottom)	45°	Fully Rounded (Top) Flat (Bottom)

*with inner & outer Carbon **with inner Carbon



JIM WUNDERLICH
Blue Devils, Riverside City College



JOHN WOOTON
University of Southern Mississippi



JAMES SPARLING
Infinity / Madison Scouts



JULIE DAVILA
Caixa Trio / Middle TN State University

TENORS BY THE NUMBERS

Tenor Sets are arranged in 7 different sized arrays to suit your physical and musical needs. Find your set, and match the configuration in the model number code.

SONIC & SHALLOW CUT TENORS
Pearl offers 2 shell depth options for tonal and weight considerations:



Sonic Cut tenors are the full-length shells of the legendary Pearl sound. Best suited for outdoor playing and large ensembles - Sonic Cut gives you the maximum power and punch you need on the field.



Shallow-Cut tenors have shorter shell depths for reduced weight, and a naturally brighter upper-overtone response. Available in all diameters and configurations.

CONFIGURATIONS	
A 8023	D 0234
B 68023	E 60234
C 668023	F 660234
	G 680234

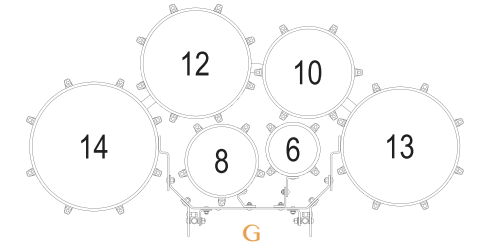
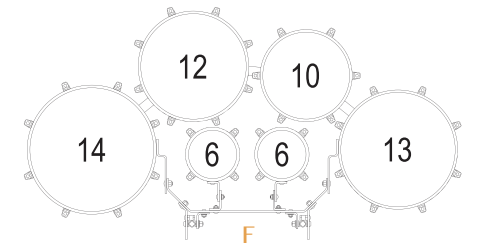
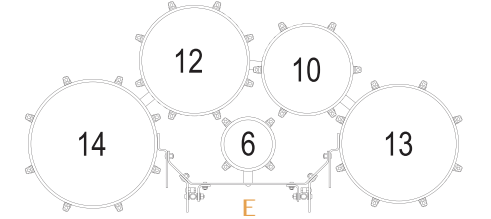
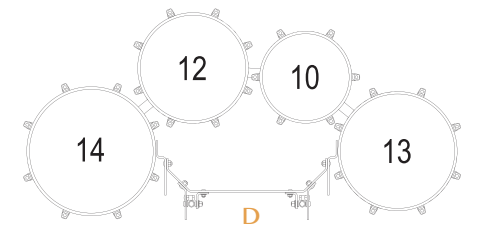
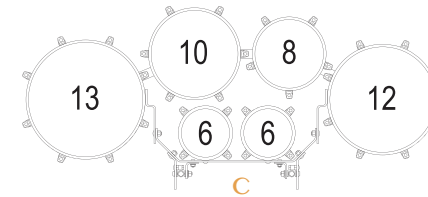
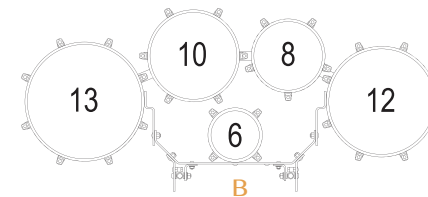
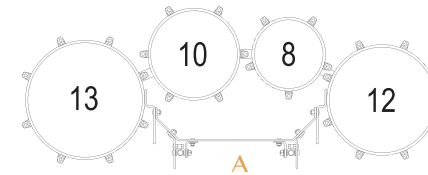

CHAMPIONSHIP SD	CHAMPIONSHIP BD	CHAMPIONSHIP TD	COMPETITOR CMSXSD	COMPETITOR CMSXSD	COMPETITOR BD	COMPETITOR TD	FFXPMD PIPEBAND SD	PIPEBAND BD / TD	TRADITIONAL TENOR
Maple	Maple	Maple	Poplar / Kapur	Poplar / Kapur	Poplar / Kapur	Poplar / Kapur	Birch	Maple	Maple
6	6	6	6	6	6	6	4	4	6
7.5	7.5	7.5	7.5	7.5	7.5	7.5	5	5	7.5
Yes (Bottom Only)	-	Yes (Top Only)	-	-	-	-	Yes	Yes (Top & Bottom)	Yes (Top & Bottom)
45°	45°	Fully Rounded (Top) Flat (Bottom)	45°	Fully Rounded (Top) 45° (Bottom)	45°	Fully Rounded (Top) Flat (Bottom)	45°	45°	Fully Rounded (Top & Bottom)



SHANE GWALTNEY
Music City Mystique



SCOTT JOHNSON
Blue Devils Drum & Bugle Corps
DCI & WGI Hall of Fame



RALPH HARDIMON
DCI Hall of Fame / The Blue Knights



JEFF QUEEN
Clinician / DCI & PASIC Solo Champion



THOM HANNUM
Univ. of Massachusetts / DCI Hall of Fame /
Carolina Crown



TIM FAIRBANKS
Rhythm X / Blue Stars

A STANDARD OF EXCELLENCE

BEFORE THE BADGE GOES ON

Superior Shell Technology And Premium Materials Make all the Difference

Pearl Concert Drums have set the standard of world class symphonic performance for over 30 years. Working with some of the world's greatest performers and orchestras, we have developed a collection of instruments that are unmatched in quality and dependability. The Philharmonic snare drums are the most successful concert drum series in history, with nearly every professional orchestra in the world boasting at least one drum in its inventory. The combination of clean design and simple operation, along with Pearl's SST shell technology, players are able to choose from a family of instruments that deliver on tone, projection, expression, color, and dynamics to suit any musical or environmental need.

Three complete lines of drums including the Concert, Symphonic, and Philharmonic Series, each offer a distinctly refined combination of material, configuration, and function. Whether you play in the finest concert halls in the world, the band room at your school, or even on the marching field of competition - there is a Pearl concert drum to perform at the highest level.



Maple - Maple is the ideal choice for concert drums due to its range of frequency response and warmth in sound quality. It has a smooth, even texture that remains durable under a wide range of conditions. Maple accepts a variety of rich lustrous finishes, making it the choice of professionals and ensembles around the world.

Poplar / Kapur - The new blended Poplar and Kapur shells of the Concert and Competitor Series bring the economy and durability of Poplar together with the lush, full tonal response of Kapur - a material usually reserved for only high end instruments. The result is a drum with a strong attack and projection with outstanding lows and punch for any environment.

African Mahogany - African Mahogany delivers a dramatic boost in lower frequencies. This makes it the ideal choice for concert toms, bass drums and larger snare drums that need to deliver a dark, forceful tone that can be heard over an ensemble.

Kapur - The 100% Kapur shell of the PBE bass drum is the best sounding drum of its kind. Darker and fuller sounding than regular mahogany, the 6 plies of Kapur are ideal for bass drums in any ensemble.



Aluminum - At 3mm thick, our exclusive precision-milled PHA cast Aluminum shell snare drum has a full bodied tone, with a higher overall pitch response than traditional maple. Aluminum provides the warm, round, full-bodied resonance of a wood shell snare, but also possesses the snap, volume and projection provided by a metal snare.



Brass - PHB Philharmonic Brass offers the highest frequency response in the Philharmonic Series with bright cutting clarity and finesse. 1.5mm thick brass Philharmonic shells have a bright, highly focused, well balanced tone perfect for situations needing more volume and clarity.

LIMITED LIFETIME WARRANTY

Pearl Drums are designed and manufactured to provide the highest standards in quality, style, appearance and playing performance. Pearl takes pride in its products and takes great care to utilize the best materials and the highest standard of craftsmanship in their manufacture.

Pearl Concert Drum Shells are guaranteed against material failure, ply separation or going out of round for life. Pearl is proud to be one of the few drum companies in the world to offer a Limited Lifetime Warranty on our drum shells.



ERIC WARD
Greater Glasgow Police Scotland Pipe Band



JEFF PROSPERIE
Hellcats United States Military Academy



DREW DUTHART
Scottish-Lion 78th Fraser Highlanders



JIM KILPATRICK
Independent / Pipe Drumming Legend



SUPERIOR SHELL TECHNOLOGY ASSURES MANUFACTURING EXCELLENCE. EVERY TIME.

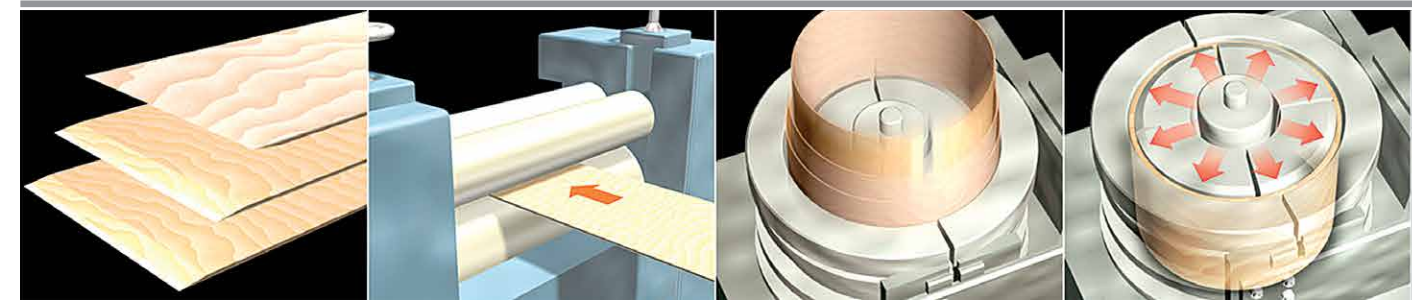

No inferior butt seams here. These tapered scarf joints seamlessly overlap for perfect shell resonance and consistency.

Our proprietary "AcoustiGlue" permeates the wood and hardens to the same consistency as the wood.

The scarf joints are carefully staggered upon insertion of the specially designed mold.

Extreme heat and over 1000 PSI pressure are simultaneously applied to the shell during formation.

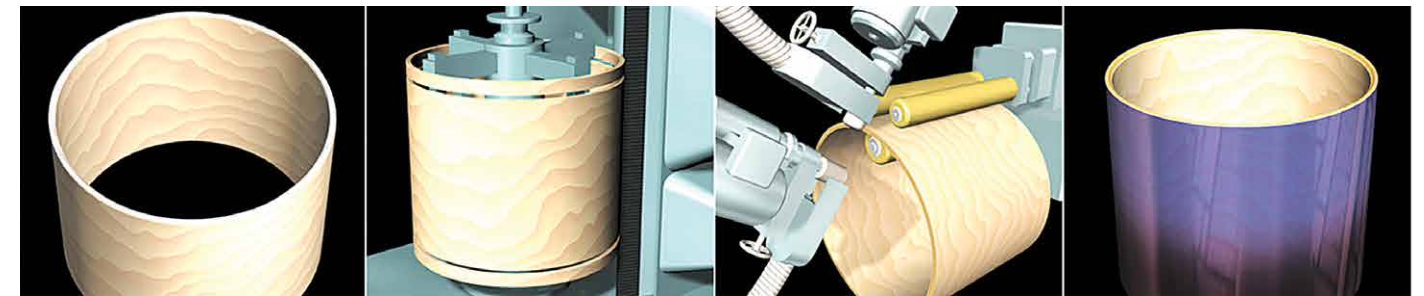

A perfect, gapless air chamber.

The shell is then trimmed and the ends squared to assure overall tuning consistency and head seal.

Our exclusive bearing edge incorporates a 45° out and 45° in, slightly inset from the exterior to optimize contact with the flat portion of the drum head.

Pearl's finishes are the industry state-of-the-art. Your choice of finish is encased in layers of highly durable urethane and polished to a high luster. Truly a work of art.

	PHILHARMONIC PHM	PHILHARMONIC PHP, PHF	PHILHARMONIC PBA	SYMPHONIC PBM, SVP, PTM	CONCERT PBE	PHILHARMONIC PHA	PHILHARMONIC PBA	PHILHARMONIC PTA	SYMPHONIC PTM	CONCERT PTE
SHELL MATERIAL:	Maple	Maple	African Mahogany	Maple	Kapur	Aluminum	Beaded Brass	African Mahogany	Maple	Poplar / Kapur
NUMBER OF PLYS:	1	6	6	6	6	1	1	6	6	6
THICKNESS (mm):	7.5	7.5	7.5	7.5	7.5	3.0	1.5	7.5	7.5	7.5
BEARING EDGE:	45°	45°	45°	45°	45°	45°	45°	45°	45°	45°



JAMES ANCONA
University of Delaware



JOSHUA TORRES
Center Grove High School, IN



SEAN VEGA
Riverside City College



JIM CASELLA
Independent / Tapspace Publications



NICK ANGELIS
University of Cincinnati



NEAL FLUM
University of Alabama

INNOVATION

PROJECTION. POWER.

CHAMPIONSHIP CARBONPLY SNARES



FFXC-1412/C301
(Chrome)

Pearl Championship CarbonPly drums bring power and innovation to the field of Marching Percussion, combining natural and synthetic shell materials for a new sonic experience. CarbonPly shells combine 6 plies of warm, resonant African Mahogany with surrounding single-ply of light-weight Carbon Fiber. The inner ply of Carbon Fiber adds crisp high frequencies into the mix with mahogany's warm qualities, while the outermost ply of Carbon Fiber provides a strong, durable, and attractive finish - #301 Carbon Fiber Matte. The resulting drums bring a completely unique Marching Battery sound that sets new standards of projection and power for marching ensembles of all sizes. Available in standard sizes and configurations by Special Order.

FEATURES

- 6 ply African Mahogany Shell
- Inner and Outer Carbon Fiber Plies
- 2 ply Snare Side Reinforcement Ring for Added Strength
- Fully Free-Floating Design
- Built to Withstand Hi Tension Usage
- 16 Strand Synthetic Gut Snares, Individually-Tunable
- #301 Carbon Fiber Matte Lacquer Finish

SIZES

- FFXC-1412/A 14" x 12"
• The Standard. Full-sized sound and projection.
- FFXC-1410/A 14" x 10"
• Same tuning range and response as 14"x12" counterpart, but lighter in projection and weight.
- FFXC-1311/A 13" x 11"
• Higher pitch range than 14" counterparts, but lighter in projection and weight.

CHAMPIONSHIP CARBONPLY TENORS



PMTC-60234N/A

The perfect complement to your CarbonPly snares, these tenors offer superior projection with enhanced frequency response for clear cutting highs and warm resonant lows. Fully rounded bearing edges for the renowned Pearl tenor voice, with the power and projection of the Sonic Cut sizes.

FEATURES

- 6 ply African Mahogany shell
- Inner and Outer Carbon Fiber plies
- 2 ply reinforcement rings for added strength
- Fully Rounded Bearing Edges for Superior Tone
- 2.3 mm solid steel SuperHoop II rims
- #301 Carbon Fiber Matte Lacquer Finish

SIZES

CarbonPly Tenor Sets Available - Sonic Cut			
PMTC-8023N/A	QUAD	8" / 10" / 12" / 13"	
PMTC-0234N/A	QUAD	10" / 12" / 13" / 14"	
PMTC-68023N/A	QUINT	6" / 8" / 10" / 12" / 13"	
PMTC-60234N/A	QUINT	6" / 10" / 12" / 13" / 14"	
PMTC-668023N/A	SEXTET	6" / 6" / 8" / 10" / 12" / 13"	
PMTC-660234N/A	SEXTET	6" / 6" / 10" / 12" / 13" / 14"	
PMTC-680234N/A	SEXTET	6" / 8" / 10" / 12" / 13" / 14"	

Shallow cut configurations also available by Special Order

CHAMPIONSHIP CARBONPLY BASS



PBDC-2814/A

PBDC-2014/A

Our Championship Series CarbonPly Bass Drums offer up Bass technology like you have never experienced. Space age technology merges with 60 years of drum-making craftsmanship to form the ultimate high volume, low frequency generator.

FEATURES

- 6 ply Maple Shell
- Inner and Outer Carbon Fiber Plies
- Superior Volume and Projection
- 100% Maple 2" Wide Black Matte Hoops
- 3 year Warranty on Shell
- 1 year Warranty on Hardware
- #301 Carbon Fiber Matte Lacquer Finish

HARDWARE OPTIONS

- Polished Aluminum (standard)
 - Chrome*
 - Powder Coat*
- * Hardware upgrade by Special Order only. Additional Charge.

SIZES

PBDC-1414/A	14" x 14"	PBDC-2414/A	24" x 14"
PBDC-1614/A	16" x 14"	PBDC-2614/A	26" x 14"
PBDC-1814/A	18" x 14"	PBDC-2814/A	28" x 14"
PBDC-2014/A	20" x 14"	PBDC-3016/A	30" x 16"
PBDC-2214/A	22" x 14"	PBDC-3216/A	32" x 16"

UNIVERSITY OF CINCINNATI
CINCINNATI, OH



CARBONPLY SHELL

Perfectly balances the warm low frequency of African Mahogany and the exuberant mid to high range tendencies of Carbon Fiber.

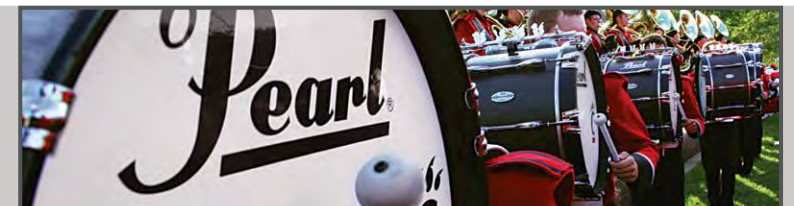



UNIVERSITY OF GEORGIA
ATHENS, GA



CARBONCORE® SHELL

100% Maple Shell with an added inner ply of ultra light Carbon Fiber. The added "CarbonCore" material takes these higher-frequency voices to their most expressive limits.

CHAMPIONSHIP CARBONCORE SNARE DRUMS



FFXIC-1412/A368

A Marching Battery produces a broad range of frequencies, from the lows in the Bass Drums all the way up to the highs in the Snare Drums and smallest Tenor Drums. Championship CarbonCore maximizes the clarity and projection of the Marching Battery across this entire range.

CarbonCore Snare Drums feature a 100% Maple Shell, with an added inner ply of ultra-light Carbon Fiber. The added "CarbonCore" enhances the expressive capability of the Snare Drum across its full dynamic range – clear and articulate at low volumes, crisp and powerful at high volumes. The warmth of tone given by 6 plies of Maple married with the boosted high frequencies given by the CarbonCore, together create a newly maximized Snare Drum for the Marching Arts.

FEATURES

- 6 plies of 100% Maple
- 1 Inside ply of light weight Carbon Fiber
- 2 ply Snare Side Reinforcement Rings for Added Strength
- Fully Free-Floating design
- Built to withstand High Tension usage
- 16 strand synthetic gut snares, individually-tunable
- Stock Finish: #368 Black Silver Burst lacquer

SIZES

- FFXIC-1412/A 14" x 12"
• The Standard. Full-sized sound and projection.
- FFXIC-1410/A 14" x 10"
• Same tuning range and response as 14"x12" counterpart, but lighter in projection and weight.
- FFXIC-1311/A 13" x 11"
• Higher pitch range than 14" counterparts, but lighter in projection and weight.



FFXIC-1311/A368



FFXIC-1410/A368

CHAMPIONSHIP CARBONCORE TENOR DRUMS



PTIC-680234N/A368
Black Silver Burst

HARDWARE OPTIONS

- Polished Aluminum (standard)
 - Chrome*
 - Powder Coat*
- * Available by Special Order

FEATURES

- 6 plies of 100% Maple
- 1 Inside ply of light weight Carbon Fiber
- 2 ply Reinforcement Rings for added strength
- Fully Rounded Bearing Edges for Superior Tone
- Available in Sonic or Shallow Cut Options
- 2.3 mm solid steel SuperHoop II rims
- 3 year Warranty on Shell / 1 year Warranty on Hardware
- Stock Finish: #368 Black Silver Burst lacquer
- Available in 62 wrap and hi-gloss lacquer finishes by Special Order

CarbonCore Tenors are made with 100% Maple Shells, each having an added inner ply of ultra-light Carbon Fiber. The added "CarbonCore" gives the Tenor section a unique EQ'ed place in the sonic mix of the Battery, which holds its own ground for expression between the Bass Drums and Snare Drums. Each drum in a CarbonCore Tenor set comes to vibrant life with an even-clearer articulation and more confident projection than ever before. On all drum sizes and across the full dynamic range, Championship CarbonCore Tenors are audible and beautiful.

CarbonCore Sonic Cut Sets Available

SIZES

PTIC-8023N/A	QUAD	8"/ 10"/ 12"/ 13"
PTIC-0234N/A	QUAD	10"/ 12"/ 13"/ 14"
PTIC-68023N/A	QUINT	6"/ 8"/ 10"/ 12"/ 13"
PTIC-60234N/A	QUINT	6"/ 10"/ 12"/ 13"/ 14"
PTIC-668023N/A	SEXTET	6"/ 6"/ 8"/ 10"/ 12"/ 13"
PTIC-660234N/A	SEXTET	6"/ 6"/ 10"/ 12"/ 13"/ 14"
PTIC-680234N/A	SEXTET	6"/ 8"/ 10"/ 12"/ 13"/ 14"

CarbonCore Shallow Cut Sets Available

PSIC-8023N/A	QUAD	8"/ 10"/ 12"/ 13"
PSIC-0234N/A	QUAD	10"/ 12"/ 13"/ 14"
PSIC-68023N/A	QUINT	6"/ 8"/ 10"/ 12"/ 13"
PSIC-60234N/A	QUINT	6"/ 10"/ 12"/ 13"/ 14"
PSIC-668023N/A	SEXTET	6"/ 6"/ 8"/ 10"/ 12"/ 13"
PSIC-660234N/A	SEXTET	6"/ 6"/ 10"/ 12"/ 13"/ 14"
PSIC-680234N/A	SEXTET	6"/ 8"/ 10"/ 12"/ 13"/ 14"

Drum Size	Sonic Cut Depth	Shallow Cut Depth
6	8	8
8	8	8
10	10	9
12	12	10
13	12	10
14	13	11

CHAMPIONSHIP MAPLE BASS DRUMS

BLUE DEVILS, Concord, CA • 15-Time DCI World Champions

Maple Basses are the perfect complement to CarbonCore Snare and Tenors. Unparalleled warmth, depth, tone, and full projection characteristic of these 100% Maple shell Bass Drums complete the CarbonCore sound and give your Marching Battery the ultimate foundation. Stocked in #368 Black Silver Burst lacquer to match.



For available sizes, features, and more information on Championship Maple Bass Drums, turn to page 14.

#1 IN TONE

FUNCTION & PROJECTION

Pearl is proud to offer absolutely stunning Artisan II Lacquer Finishes on a select series of products. Artisan II Lacquer is Pearl's proprietary process that simulates the look of real wood veneer without endangering rare and precious forests, achieving an exotic look with an environmentally friendly approach!

Artisan II is the industry standard for cutting edge styling and provides the finishing touch that compliments the superb quality and sound of Pearl drums. The Artisan II finish also acts as a protective layer to extend longevity in your drums and ensure the best possible sound.

Pearl's sound quality meets its visual counterpart with Artisan II Lacquer finishes!



#818 BURL WALNUT FADE

THE TROOPERS
CASPER, WY
WITH #805 MOCHA TAMO



50 SPECIAL ORDER LACQUER FINISHES:

Pearl Super High Gloss Finishes feature a 31 step process where successive layers of premium polyurethane are hand applied and allowed to cure over a two week span to create the "mile-deep" and super-durable finishes that Pearl is famous for.

Choose from 50 high gloss lacquer finishes, 3 standard wraps and 12 special order wrap finishes to customize your line. See back cover for complete color chart.



CHAMPIONSHIP MAPLE FFX SNARE DRUMS



It's called Championship Series for a reason. Untouchable by its competitors, absolutely committed to Being the Best. Championship Maple drums stand out as #1 in tone, physical function, and projection. Every drum in the series is designed to its lightest possible weight so performers can push the envelope of visual performance while producing the very best sounds.

Pearl's FFX Snare Drums are the crown jewels of the Championship Series. They are the total package: lightweight mobility, clear projection, and complete richness of sound. A fully Free-Floating design allows unhindered shell response from the 6 ply 100% Maple shell that "floats" in a super lightweight aircraft aluminum frame. The FFX is the best in its class and is competitively proven having contributed to more than a few High Percussion Awards.

Championship Maple Series - *Proven trophy magnets year after year.*



FFXL-1311/C377
Scarlet Sparkle Burst

FEATURES

- 6 ply 100% Maple Shell
- Free-Floating Design
- Lightweight Aircraft Aluminum Frame
- Aluminum Alloy Edge Ring and Hoops to Withstand the Highest Tensions
- Individually Tunable Snares
- One Knob Quick Release Strainer Allows Fast Head Changes
- 6 Acoustically Located Air Vents
- 3 Year Warranty on Shells / 1 Year Warranty on All Hardware
- Chrome or Powder Coated Hardware Available

SIZES

- | | |
|--|-----------|
| FFX-1412/A | 14" x 12" |
| • The Standard. Full-sized sound and projection. | |
| FFX-1410/A | 14" x 10" |
| • Same tuning range and response as 14"x12" counterpart, but lighter in projection and weight. | |
| FFX-1311/A | 13" x 11" |
| • Higher pitch range than 14" counterparts, but lighter in projection and weight. | |



6-Ply 100% Maple Shell
Clear projection and complete richness of sound



Aluminum Alloy Edge Ring and Hoops to Withstand the Highest Tensions



S-115BA Strainer (butt side)
16 strand synthetic gut snares Individually tunable
S-115RA Strainer (release side)



PHANTOM REGIMENT
ROCKFORD, IL

CHAMPIONSHIP BASS DRUMS



PBD-241426
Brushed Silver

6 ply 100% Maple shells offer maximum resonance and huge sub-frequency projection. To compliment the Maple shells, 2" wide Maple Hoops are secured by extra wide claws that disperse tension over a larger area for consistent tuning. Lightweight high strength one piece cast aluminum casings and 6 mm case hardened tension bolts provide uncompromising strength while still keeping you light on your feet.

FEATURES

- 6 ply 100% Maple Shell
- 2" Wide Maple Hoops
- Remo Smooth White Ambassador® Heads w/Logo
- Die-Cast Aluminum Alloy Casings
- Oversized Triple Reinforced Claws
- 100% Maple 2" Wide Matte Black Hoops
- 6 Acoustically Located Air Vents
- 6 mm Case-Hardened Tension Bolts
- 3 Standard Covered Finishes
- Available in 50 High Gloss Lacquer Finishes*
- Available in 12 Custom Wrap Finishes*
- 1 Year Hardware Warranty / 3 Year Shell Warranty

*Special Order Only

SIZES

PBD-1414	14" x 14"
PBD-1614	16" x 14"
PBD-1814	18" x 14"
PBD-2014	20" x 14"
PBD-2214	22" x 14"
PBD-2414	24" x 14"
PBD-2614	26" x 14"
PBD-2814	28" x 14"
PBD-3016	30" x 16"
PBD-3216	32" x 16"

CHAMPIONSHIP TRADITIONAL TENOR

PTD-1412N/A26
Brushed Silver



The PTD Traditional Tenor Series is the answer for all drumlines using single drums in either vertical sling, or fully horizontal bass-style positions. 100% 6-ply Maple Shells and Die-Cast Aluminum lug casings provide the sound and durability to match the FFX snares, PMT tenors and PBD Bases of the Championship Maple Series.

FEATURES

- 6 ply 100% Maple Shell
- 2 ply Maple Reinforcement Ring
- Fully Rounded Bearing Edges
- 8 Aluminum Die Cast Lugs
- 2.3 mm SuperHoop II
- Stock Wrap Colors #33, #46, #26

SIZES

PTD-1412N/A	14" x 12"
PTD-1512N/A	15" x 12"
PTD-1614N/A	16" x 14"

CHAMPIONSHIP TENORS SHALLOW CUT



PSMT-680234N/A33
Pure White

Championship Shallow Cut Marching Toms shell design provides tight focus while reducing overall mass for fast moving high energy performances. Maple Shells deliver rich, robust sound while the rounded bearing edges deliver that distinctive Pearl sound. Case-hardened Aluminum tension casings offer improved tuning accuracy and even dispersion of tension while 6 mm case hardened tension bolts permit the highest tunings without failure.

FEATURES

- 6 ply 100% Maple Shells for Strength & Richness
- Shells with Shallow Cut Provides Extreme Focus & Articulate Response
- Rounded Bearing Edges Deliver Classic Pearl Tone
- Lightweight = Increased Mobility
- 2 ply Reinforcement Rings

SIZES

Model	Configuration	Drum Sizes
PSMT-8023N/A	QUAD	8" / 10" / 12" / 13"
PSMT-0234N/A	QUAD	10" / 12" / 13" / 14"
PSMT-68023N/A	QUINT	6" / 8" / 10" / 12" / 13"
PSMT-60234N/A	QUINT	6" / 10" / 12" / 13" / 14"
PSMT-668023N/A	SEXTET	6" / 6" / 8" / 10" / 12" / 13"
PSMT-660234N/A	SEXTET	6" / 6" / 10" / 12" / 13" / 14"
PSMT-680234N/A	SEXTET	6" / 8" / 10" / 12" / 13" / 14"

Championship Maple Shallow Cut Sets Available

CHAMPIONSHIP TENORS SONIC CUT



PMT-680234N/A26
Brushed Silver

FEATURES

- 6 ply 100% Maple Shell
- 2 ply Maple Reinforcement Rings
- Fully Rounded Bearing Edges for Optimal Tone
- Features Pearl's Sonic Cut for Volume & Projection
- 2.3 mm Solid Steel SuperHoop II Rims
- Rubber Tom Trim for Shell Protection
- 6 mm Case Hardened Tension Bolts
- Available in 3 Standard Covered Finishes
- Available in 50 High Gloss Lacquer Finishes*
- Available in 12 Custom Wrap Finishes*
- 1 Year Hardware Warranty / 3 Year Shell Warranty

*Special Order Only

SIZES

PMT-8023N/A	QUAD	8" / 10" / 12" / 13"
PMT-0234N/A	QUAD	10" / 12" / 13" / 14"
PMT-68023N/A	QUINT	6" / 8" / 10" / 12" / 13"
PMT-60234N/A	QUINT	6" / 10" / 12" / 13" / 14"
PMT-668023N/A	SEXTET	6" / 6" / 8" / 10" / 12" / 13"
PMT-660234N/A	SEXTET	6" / 6" / 10" / 12" / 13" / 14"
PMT-680234N/A	SEXTET	6" / 8" / 10" / 12" / 13" / 14"

Championship Maple Sonic Cut Sets Available

Drum Size	Sonic Cut Depth	Shallow Cut Depth
6	8	8
8	8	8
10	10	9
12	12	10
13	12	10
14	13	11

Pearl Championship Sonic Cut is renowned for its exceptionally full tenor sound. Fully rounded bearing edges give a focused character to the sound, while the Sonic Cut of each shell provides outstanding projection and volume. 2.3mm SuperHoop II rims and case-hardened tension bolts are made to be exceptionally strong and handle the rigors of even the most aggressive tuning schemes.



SLG-100
Triple Function Sling is designed for use with all snare and traditional tenor drums



LR-40
Locking Leg Rest for Snare and Tenors up to 20"



HIGH VALUE

AFFORDABLE PRICE

Competitor Series offers high value results at an affordable price. New features include upgraded construction on the entire Series with composite shells of durable Poplar and full sounding Kapur. Competitor Series is also tremendously light weight for Marching Drums, a sure benefit for any band who has smaller players or needs to be extra light on their feet. Take the field with a Marching Battery of incredible quality, without incredible weight!



FATHER RYAN HIGH SCHOOL
NASHVILLE, TN



COMPETITOR SNARE DRUM CMSX



CMSX-1412/C33
Pure White

The CMSX Snare Drum offers many features of the FFX Series Snare Drums, such as a free-floating shell with an aluminum edge ring, which relieves all batter head tension from the 6-ply shell, and polished aluminum tension posts for a classy, sleek look.

FEATURES

- 6 ply Poplar / Kapur Shells
- Lightweight Construction
- 2.3 mm Triple Flanged SuperHoop II
- Available in 13" and 14" Sizes
- CMSX Aluminum Edge Ring Relieves Shell Tension
- CMSX Compatible with CXS and MXS carriers
- Ultra Sensitive 12 Strand Synthetic Snares
- Lever Activated Snare Strainer
- Standard Covered Finishes: #33 Pure White, #46 Midnight Black

SIZES

- CMSX-1412/C 14" x 12"
- CMSX-1311/C 13" x 11"



6-Ply Poplar / Kapur Shell
Durability of Poplar with lush, full tonal response of Kapur



Lever Activated Snare Strainer

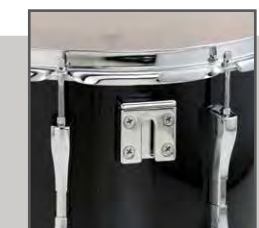

CT-1216 Clip Mount

COMPETITOR SNARE DRUM CMS



CMS-1309/C46
Midnight Black

The CMS Snare Drum offers Pearl quality at the lightest weight of any Marching Drum available. Constructed using the same Superior Shell Technology (SST) as Pearl's Championship Series, you can be sure that CMS Snare Drums will deliver crisp response reliably through years of use. Chrome 3-part full-length Die Cast lugs and triple-flanged steel hoops make tuning a breeze, and built in snare guards on each side of the bottom hoop add built in protection to CMS Snare Drums. The perfect choice for any band wanting to use Mylar drumheads for that classic Marching Battery sound.

FEATURES

- 6 ply Poplar / Kapur Shells
- Lightweight Construction
- 1.6 mm Triple Flanged Steel Hoops
- Available in 13" and 14" Sizes
- Ultra Sensitive 12 Strand Synthetic Snares
- Lever activated snare strainer
- Standard Covered Finishes: #33 Pure White, #46 Midnight Black

SIZES

- CMS-1412/C 14" x 12"
- CMS-1309/C 13" x 9"

COMPETITOR BASS DRUMS



CMB-1814N/C33
Pure White

CMB-2814N/C33
Pure White

Pearl's Competitor Series Bass drums offer tremendous value and performance. Upgraded construction with composite shells of durable Poplar and full sounding Kapur featuring 6 strategically placed air vents make these drums highly efficient low frequency projectors. Durable 6 ply maple hoops, triple-reinforced claws, and high-strength marching lugs assure perfect tuning season after season.

FEATURES

- 6 ply Poplar/ Kapur Shells
- 6 ply Matte Black Maple Hoops for a Classic Finish
- 6 Acoustically Located Air Vents
- Lightweight for Increased Mobility
- Chrome 3-Part Full-Length Marching lugs
- 8 Sizes Available
- Standard Covered Finishes:
#33 Pure White, #46 Midnight Black

SIZES

CMB-1414N/C	14" x 14"
CMB-1614N/C	16" x 14"
CMB-1814N/C	18" x 14"
CMB-2014N/C	20" x 14"
CMB-2214N/C	22" x 14"
CMB-2414N/C	24" x 14"
CMB-2614N/C	26" x 14"
CMB-2814N/C	28" x 14"

COMPETITOR TENORS



CMT-8023N/C46
Midnight Black



CMT-8023N/C46
with MX4BB-1

Competitor Tenors offer extreme value and performance to put your Band in the Winner's Circle. New additions include upgraded construction with composite shells of durable Poplar and full sounding Kapur feature a rounded bearing edge like Championship Drums for a robust yet projecting tone. Pearl's sonic cut on the shell bottoms project that big sound right to your audience. The lightweight zinc lug casings provide precise even tuning. The bottoms of the shells are protected by rubber Tom trim, and lightweight aluminum Tom spacers keep positioning perfect.

MX QUAD & TRIO BACK BAR

Tenor rails are available in Quad or Trio configurations. Both feature precise level mounting of toms and provide tilt up function & detach quickly from the carrier J rods.



MX4BB-1 Quad Back Bar

MX3BB-1 Trio Back Bar

FEATURES

- 6 ply Poplar/ Kapur Shells
- Aluminum Tom Spacers
- Fully Rounded Bearing Edges
- Pearl's Sonic Cut for Amazing Projection
- Includes Rubber Tom Trim for Shell Protection
- Lightweight Construction
- Chromed Zinc Lug Casings
- Steel Triple Flanged Hoops
- CMT Tenors Compatible with MXT carriers
- Drum & Carrier Packages Available
- Standard Covered Finishes: #33 Pure White, #46 Midnight Black

SIZES

CMT-802N/C	TRIO	8/10/12
CMT-8023N/C	QUAD	8/10/12/13



FATHER RYAN HIGH SCHOOL
NASHVILLE, TN

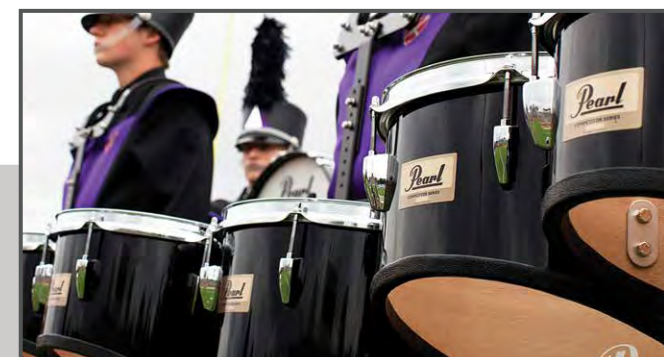

INSTRUMENTS
OF CHAMPIONS

Championship Pipe Drums combine the ultimate in build quality, tunability, and appearance. The free-floating Birch shells of Championship Pipe Snare Drums deliver the "crack" and "snap" that make your tunes groove, while also providing the most expressive canvas for low-dynamic playing. Paired with the warmth of Maple Tenors and Maple Bass Drums, the Championship Pipe Battery gives a fantastic sonority across the entire frequency range. Walk onto the competition field with full confidence. Pearl Championship Pipe Series... *the chosen Instruments of Champions.*



GREATER GLASGOW POLICE
SCOTLAND PIPE BAND
GLASGOW, SCOTLAND



MEDALIST
CHAMPIONSHIP PIPE SNARE DRUM



The new Championship "Medalist" Snare Drum is the lightest in its class, just 6.25Kg / 13.8lbs. The reduction in weight has been reached by looking into every detail of the snare. Firstly the shell construction; it's a 100% Birch 5.0mm even 4 ply shell which resulted in a huge weight reduction. Secondly, the top and bottom strainer have been redesigned which resulted in a 35% weight reduction compared to our previous model.

Next to the reduction in weight other improvements have been made. Pearl have created new Snare Wires which are meticulously soldered, placed and even tensioned. All the Aluminum hardware including the aluminum alloy edge rings and rims are now fitted with our new Shiny Anodized finish, which give the drums a brilliant finish at the same time a durable and easy to maintain finish; to withstand all weather conditions.



FFXPMD-1412 126
Emerald Mist



U.S. Patent #7671261

FEATURES

- 100% Birch 4 ply + 2 ply Reinforcement Rings
- New "Lightest Pipe Band Snare Drum, Ever!" Just 6.25Kg/13.8lbs
- New Design Top & Bottom Strainers, Weight Reduction Over 35%
- Chrome Snare Wires for Increased Brightness
- New Shiny Anodized Hardware Finish
- High Tension Aluminum Alloy Edge Rings and Counter Hoops
- 45 Degree Bearing Edge for a Great Cutting Sound
- Remo Cybermax Kevlar® Head
- Compatible with Pearl MX T-Frame and CX Airframe Carriers

SIZES

- FFXPMD-1412 14" x 12"
Birch Shell, Polished Aluminum Hardware
- Standard Lacquer Finishes:
#109 Arctic White
#110 Sequoia Red
#122 Black Mist
#126 Emerald Mist



CHAMPIONSHIP PIPE TENOR



TDP-1412 110
Sequoia Red

Championship Pipe Band Tenor shells are comprised of 4 plies of Maple with 4 ply Maple Reinforcement Ring, 1" Maple hoops, and Aluminum Tube Lugs for great tone and lighter weight. Extended range and sizes are now available to meet the tonal range required in contemporary pieces. The case-hardened tension rods provide consistent head tensioning and the top and bottom heads are independently adjustable. Includes a carrying hook and is compatible with our SLG-100 Triple Function Sling and LR-40 Leg Rest.

FEATURES

- 4 ply Maple Shells with 4 ply Maple Reinforcement Ring
 - 1" Maple Hoops
 - Die Cast Rubber Insulated Claws
 - Compatible with SLG-100 Sling and LR-40 Leg rest
 - High-Gloss Lacquer Finishes
- #109 Arctic White, #110 Sequoia Red
#122 Black Mist, #126 Emerald Mist

SIZES

TDP-1412	14" x 12"
TDP-1512	15" x 12"
TDP-1612	16" x 12"
TDP-1812	18" x 12"
TDP-2012	20" x 12"
TDP-2014	20" x 14"
TDP-2212	22" x 12"
TDP-2214	22" x 14"

Greater Glasgow Police Scotland Pipe Band, Glasgow, Scotland



CHAMPIONSHIP PIPE BASS PB & BDP

Championship Pipe Band Bass drums give you full low frequencies with resounding warmth. The 4 ply Maple shells with 4 ply Maple Reinforcement Ring with 1.5" Maple hoops are meticulously finished in high gloss lacquers in both series of Pipe Bass drums. BDP Series basses have Aluminum Tube Lugs for maximum resonance and reduced weight. PB Series Drums have a 3 part cast lug that runs the full length of the shell for a more economical choice. Both Series are compatible with either CX or MX Series Carriers.



Oran Mor Pipe Band, Albany, NY



BDP-2814 122
Black Mist



PB-2814N/C 126
Emerald Mist

BDP FEATURES

- 4 ply Maple shells with 4 ply Maple Reinforcement Ring
- 1.5" Maple Hoops
- Full Length Aluminum Tube Lugs
- Die Cast Rubber-Lined Claws
- 3 Acoustically Placed Air Vents
- Carrying Hook
- Compatible with CXB or MXB Carriers
- High Gloss Lacquer Finishes

SIZES

BDP-2612	26" x 12"
BDP-2812	28" x 12"
BDP-2814	28" x 14"
BDP-2816	28" x 16"
BDP-3016	30" x 16"

PB FEATURES

- 4 ply Maple shells with 4 ply Maple Reinforcement Ring
- 1.5" Maple Hoops
- Oversized Triple Reinforcement Claws
- Full Length 3-part Die Cast Lugs
- 45 Angle-Cut Bearing Edges
- Compatible with CXB or MXB Carriers
- High Gloss Lacquer Finishes

SIZES

PB-2812N/C	28" x 12"
PB-2814N/C	28" x 14"
PB-2816N/C	28" x 16"



Die Cast Rubber-Lined Claws



Full Length Aluminum Tube Lugs



Oversized Triple Reinforcement Claws



Full Length 3-part Die Cast Lugs



SLG-100 Triple Function Sling

LR-40 Leg Rest

LR-40 (Attached)





CX AIRFRAME CARRIER CORPS EXTREME



Finally! A carrier that combines lightweight simple design with rugged durability: CX Airframe by Pearl. A revolutionary breakthrough in carrier design featuring a solid rod form-fitting upper body frame attached to a lightweight aluminum belly plate.

The plush shoulder and belly pads are removable for cleaning and are built with a "Stealth" design that allows CX Carriers to practically disappear under uniforms.

The ACS Agility Control System Belt (pictured above) performs two important functions: 1) it reduces back strain by transferring the weight of the instrument to the players hips, thereby reducing fatigue and the chance of injury by lowering the center of gravity; and 2) it unites the player to the instrument for unencumbered performance, allowing players to more easily meet the movement demands of contemporary drill design.

Highly adjustable, with minimal moving parts make this the carrier for players of all sizes and skill levels.

CXT-1 TENOR CARRIER INCLUDES CXBB-1

CXT-1 with CXBB-1



CXBB-1 can be adjusted into 4 different positions to allow both 6" and 8" drums.

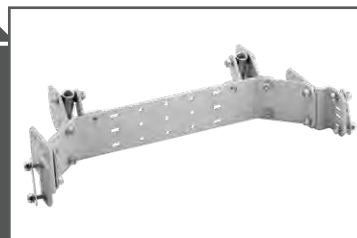

CXBB-1 TENOR BACK BAR

Pearl's CXBB-1 Tenor back bar provides absolute level positioning of all your toms. It permits pinpoint placement and perfect height adjustment with full ease of movement due to its lightweight aluminum construction.

CXB-1 BASS CARRIER

CXB-1



CXS-1 SNARE CARRIER INCLUDES CXSA-1

CXS-1 with CXSA-1



Pearl's CXSA-1 snare attachment provides rigid mounting stability for all free floating snares. The attachment has the ability to angle drums with full tilt up function, and lifts quickly off the J-rods when at rest.

CXSA-1



UPGRADED: New additions include Tenor Agility J-rods (patent pending) that increase upper leg range of motion for tenor players by reducing the J-rod profile between the belly plate and the back bar. Modern body movement is no longer a fight between the drum and the player. The simple and efficient construction unites the drum and player in a common purpose, and looks good under a uniform at the same time.



BOISE STATE UNIVERSITY
BOISE, ID

MX T-FRAME CARRIER

Every part has a purpose. Nothing left to take away for pure performance. Explore the range of capabilities the MX T-Frame offers.



- Superior comfort
- Easy to conceal under uniform
- Lightweight, sleek form-fitting design
- Adjusts to fit any player

- Rugged durability
- Optimal positioning for instruments

MXSA-1 Snare mount with tilt up function

MXS-1 Snare Carrier

MXSA-1 Tilting Snare Mount
Compatible with FFX, CMSX, CMS Snare Drums



MXSA-1 SNARE MOUNT

MXSA-1 Snare mount allows secure mounting of both Free Floating FFX and CMSX drums and Spade mounts like the CMS Competitor Snares. The Tilting attachment provides a quick flip up function and allows for tilt positioning.

MX T-FRAME MARCHING EXTREME CARRIER

The Pearl MX T-Frame carriers offer elegant simplicity combined with solid dependability. These super light frames provide sleek comfort with a wide range of adjustability to fit every size player. A straight forward adjustment with minimal hardware make these carriers the clear choice for any band, and is ideal for smaller players.



PIPE SNARE CARRIER

MXSP-1
with CXSA-1



BASS CARRIER

MXB-1



TENOR CARRIER

MXT4-1
with MX4BB-1



MX4BB-1 Quad Back Bar



MX3BB-1 Trio Back Bar

MX QUAD & TRIO BACK BAR

Tenor rails are available in Quad or Trio configurations. Both feature precise level mounting of toms and provide tilt up function & detach quickly from the carrier J rods.



BLUE DEVILS B
CONCORD, CA

MARCHING BASS STAND

Pearl's MXB-1 Marching Bass Drum Stand keeps even the largest tonal bass drums stable and secure. Its 4-arm adjustable basket and extreme range of height adjustment make it a perfect fit with perfect feel for any sized player on any sized drum.

Easy to use -
Rock Solid, any place, any time.

FEATURES

- 4-Arm Adjustable Basket
- Height/Range Adjustable Double-Braced Front Leg
- Oversized No-Slip Rubber Feet
- Wide Open-Stance Rear Legs Allows Standing Room
- Easy To Operate Height Adjustment

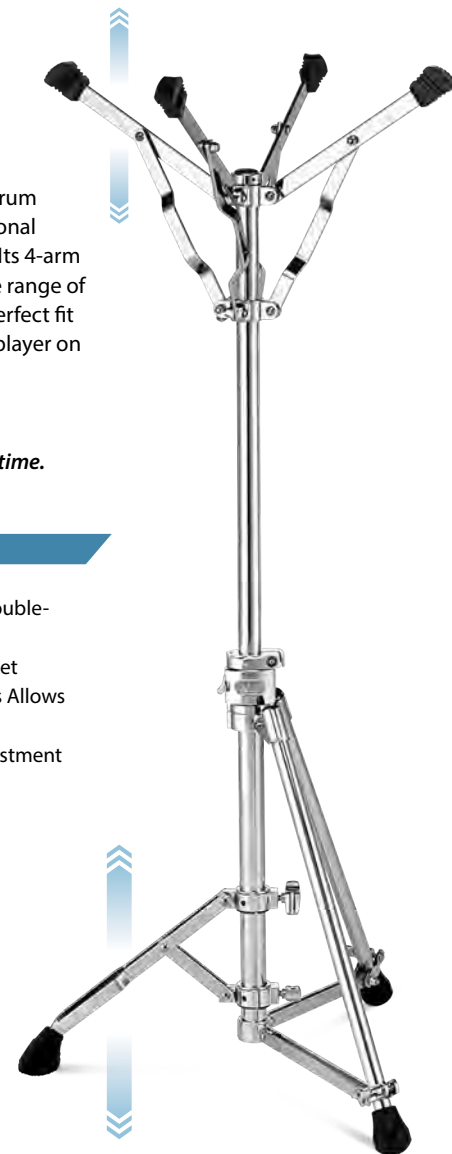

MBS-3000



13.5" Adjustment Range

STADIUM FUNCTIONALITY

Pearl Advanced Marching Hardware Snare, Tenor, and Bass Drum Stands include a height/range adjustable front leg to facilitate drumline performances on level ground and in stadium bleachers. The sturdy double-braced front leg adjusts over a 13.5" range on the center post via two ergonomic Ultragrip wing bolts. The leg can be adjusted from a narrow closed position to a high extended position virtually parallel to the ground.

MARCHING SNARE STAND

Pearl's Advanced Marching Snare Stand is designed to deliver Rock Solid Stability and Long-Life Performance from rehearsal, to stadium bleachers, to the field, and everywhere else your playing takes you. The MSS-3000 is compatible with CX Airframe and MX T-Frame Carrier Systems and only requires a drum key for adjustment.



MSS-3000

FEATURES

- 13.5" Height/Range Adjustable Double-Braced Front Leg
- Oversized No-Slip Rubber Feet
- Wide Open-Stance Rear Legs
- Stability Arm
- Easy To Operate Height Adjustment



MARCHING TENOR STAND

The MTS-3000 Advanced Marching Tenor Stand provides an optimal experience and feel for Tenor players. The low-profile Stability Arm is easy to use and super strong to keep the drums level and evenly supported no matter how much power the music requires. The MTS-3000 is compatible with CX Airframe and MX T-Frame Carrier Systems and requires no tools other than a drum key to make adjustments.



MTS-3000

FEATURES

- Stability Arm for a Solid Playing Surface
- Height/Range Adjustable Double-Braced Front Leg
- Oversized No-Slip Rubber Feet
- Wide Open-Stance Rear Legs Allows Standing Room
- Easy To Operate Height Adjustment



UNIV. OF MASS.
AMHERST, MA

MARCHING SOUND ACCESSORIES



PBL-30 Low
PBL-20 Medium
PBL-10 High



HH-5X / HH-4X Marybell / Isabell
PAR-100 Anarchy Crasher
PTB-60CS Brazilian Tamborim & Mount

DRUM CASES AND COVERS



PD-1412 Snare Case (Fits 13" & 14" Snare Drums)
PD-2414 Bass Case
PD-8004 Tenor Case (Quad / Quint / Sextet)

DRUM CASES	
14" x 12"	PD-1412
14" x 14"	PD-1414
16" x 14"	PD-1614
18" x 14"	PD-1814
20" x 14"	PD-2014
22" x 14"	PD-2214
24" x 14"	PD-2414
26" x 14"	PD-2614
28" x 14"	PD-2814
30" x 16"	PD-3016
32" x 16"	PD-3216
Tenor	PD-8004

DRUM COVERS	
13"	MDCG-13
14"	MDCG-14
14"	MDCG-14B
16"	MDCG-16
18"	MDCG-18
20"	MDCG-20
22"	MDCG-22
24"	MDCG-24
26"	MDCG-26
28"	MDCG-28
30"	MDCG-30
32"	MDCG-32

TENOR COVERS	
10-12-13-14"	MDCG-0234
8-10-12-13" or 8-10-12-14"	MDCG-8023

Protect your equipment while in transit or long term storage with Pearl custom-molded cases. Protect your equipment while playing with custom-fit covers.



MDCG-24
MDCG-14 / MDCG-13
MDCG-0234 / MDCG-8023

MARCHING ACCESSORIES



BMH-100 Pearl Bass Drum Mallet Holder with Built-in Rim Shooters
BDR-1 Bass Drum Rim Shooter
BMH-1 Bass Drum Mallet Holder
MUH-10 Multi Use Holder
MUH-10T Multi Use Holder



MUH-20 FFX Snare Accessory Mount
PCS-11 Bass Drum Accessory Mount
MSB-1 Single Stick Bag
MMB-1 Mallet Holder with Velcro Straps
MSB-2 Double Stick Bag
14" Sound Projector with Velcro Tape Mounting



TS-14 Bass Drum Tone Strips Self adhesive and mounts directly to the bass head for easy muffling
LR-40 Leg Rest
SLG-100 Sling
K-030 High Tension Drum Key

University of Washington, Seattle, WA





SR-500 TRIAD SILENT STRAINER

At the heart of the World Famous Philharmonic snare drum is the revolutionary SR-500 strainer system. The Triad Silent Strainer System provides three individual adjustment knobs allowing you to fine tune the optimum tension for each type of snare material mounted on the drum, and a single global adjustment knob on the butt side for quick overall tension adjustments. An easy to reach single throw lever quickly and silently engages or releases all snare assemblies.



PHILHARMONIC SOLID PLY MAPLE



PHM-1450
#204 High Gloss Walnut Bordeaux

PHM-1465
#204 High Gloss Walnut Bordeaux

Each PHM Philharmonic Snare Drum is hand-formed from a single ply of fully aged prime Maple to achieve the pinnacle of concert snare drum attack, response, dynamic capability, and tonal color in one instrument. Truly professional quality. Truly amazing performance.

FEATURES

- Solid 7.5mm 100% Maple Shell
- Die Cast Hoops & Tube Lugs
- High-Gloss Walnut Bordeaux Finish
- SR-500 Triad Silent Strainer System
- Graduated Tension Snares
- Vintage Style Snare Bed
- Remo Renaissance Heads

SIZES

- | | |
|----------|------------|
| PHM-1450 | 14" x 5" |
| PHM-1465 | 14" x 6.5" |

**Available in #204 High Gloss Walnut Bordeaux.
#103 Piano Black can be special ordered.
(Extra delivery time may be required.)*

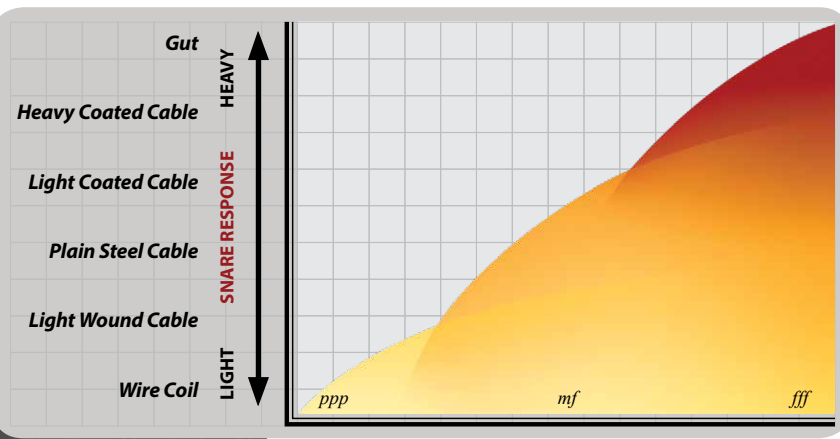

VOLUME / DYNAMIC



CHRISTOPHER DEVINEY
PHILADELPHIA ORCHESTRA

SNARE ASSEMBLY TYPES

The snare assembly material itself can have a major impact on sensitivity, dynamic range, projection and response. In addition, the way the snares are attached and function with the snare throw will equally affect the musicality of the instrument.



PHP-1440
#101 High Gloss Walnut



PHP-1450
#101 High Gloss Walnut



PHP-1465
#101 High Gloss Walnut



PHP-1480
#103 Piano Black

PHILHARMONIC 6-PLY MAPLE

PHP Philharmonic 6ply 100% Maple shell delivers the power to be heard, with dark, full tonal response that has become the preferred sound of orchestras and artists around the world. From the lightest touch to the thickest roll, these drums have the warm response every player searches for.

FEATURES

- 6ply 100% Maple Shell
- Die Cast Hoops & Tube Lugs
- Single Flange Rims on 13" x 4" & 14" x 4" drums
- Triad Silent Strainer System
- Graduated Tension Snares
- Vintage Style Snare Bed
- Remo Renaissance Heads

SIZES

- | | |
|----------|------------|
| PHP-1340 | 13" x 4" |
| PHP-1440 | 14" x 4" |
| PHP-1450 | 14" x 5" |
| PHP-1465 | 14" x 6.5" |
| PHP-1480 | 14" x 8" |

**Available in #101 High Gloss Walnut & #103 Piano Black*



PHB-1440



PHB-1450



PHB-1465



PHB-1480

PHILHARMONIC BEADED BRASS

Pearl's line of Brass Philharmonic drums offers a bright, highly focused, well balanced tone perfect for situations needing more volume and projection. These beautiful drums feature a 1.5mm Black Nickel plated Brass shell.

FEATURES

- 1.5mm Brass Shell
- Triad Silent Strainer System
- Graduated Tension Snares
- Vintage Style Snare Bed
- Single Flange Rims & Tube Lugs
- Remo Renaissance Heads

SIZES

- | | |
|----------|------------|
| PHB-1440 | 14" x 4" |
| PHB-1450 | 14" x 5" |
| PHB-1465 | 14" x 6.5" |
| PHB-1480 | 14" x 8" |



PHA-1440



PHA-1450



PHA-1465

PHILHARMONIC CAST ALUMINUM

The Philharmonic Cast Aluminum Snare Drum offers a warmth and richness similar to wood, but with the increased brightness and attack characteristic of metal shell snare drums. These incredible drums represent state-of-the-art design and craftsmanship, allowing the player unprecedented control over the tone, dynamics and performance of the instrument.

FEATURES

- 3mm Cast Aluminum Shell
- Die Cast Hoops & Tube Lugs
- Single Flange Rims on 14" x 4"
- Triad Silent Strainer System
- Graduated Tension Snares
- Vintage Style Snare Bed
- Remo Renaissance Heads

SIZES

- | | |
|----------|------------|
| PHA-1465 | 14" x 6.5" |
| PHA-1450 | 14" x 5" |
| PHA-1440 | 14" x 4" |

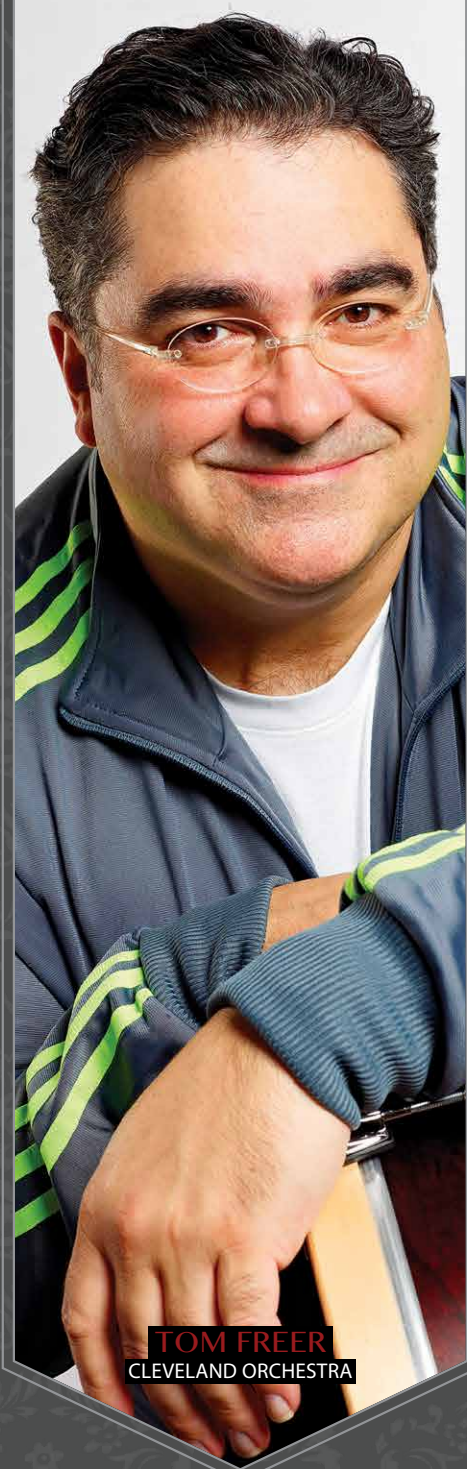

TOM FREER
CLEVELAND ORCHESTRA

PHILHARMONIC FIELD DRUMS

PHX African Mahogany Concert • The Philharmonic PHX-1580 African Mahogany concert snare drum adds a Classic American sound to the Philharmonic line up. The 15" x 8" shell size and unique synthetic gut snares recall a true "concert march" sound that John Phillip Sousa himself would recognize, while still providing complete tonal control from the SR-500 Triad Strainer and Snare System. Wood hoops, Slim-line Chrome lugs, and a High gloss finish make this model a beautiful collector's drum with instant tonal appeal for players and music directors alike across a wide range of musical styles and genres.

FEATURES

- 15" x 8" #210 Matte Walnut
- 4-Ply African Mahogany Shell with 4-ply Maple Reinforcement Rings
- 6Ply 100% Maple Rims
- 8 Slim-line Chrome Tube Lugs with Insulated Low Profile Chrome Claws
- SR-500 Triad Strainer with 2 Synthetic Gut and 1 Heavy Coated Cable Assemblies
- Renaissance Diplomat Batter and Renaissance Snare Side Heads by Remo



PHX-1580
#210 Matte Walnut

PHF Philharmonic Series Field Drums • PHF Philharmonic Series Field Drums offer the emotion and power of traditional rope marching drums, combined with all the technologically advanced features common with our other Philharmonic Snare. This is without a doubt the finest traditional style Field Drum on the market.



PHF-1412
#101 High Gloss Walnut



PHF-1616
#101 High Gloss Walnut

FEATURES

- 6 ply 100% Maple Shell
- SuperHoop II & Tube Lugs
- Triad Silent Strainer System
- Graduated Tension Snare
- Vintage Style Snare Bed
- Remo Renaissance Heads

SIZES

PHF-1412	14" x 12"
PHF-1616	16" x 16"

* Available in #101 High Gloss Walnut & #103 Piano Black

LIMITED LIFETIME WARRANTY



Pearl Concert Drum Shells are guaranteed against material failure, ply separation or going out of round for life. Pearl is proud to be one of the few drum companies in the world to offer a Limited Lifetime Warranty on our drum shells.

PHILHARMONIC SERIES TOMS

Pearl's Philharmonic Series Toms offer the ultimate in uncompromising sound and craftsmanship with their 6 ply African Mahogany shell construction.



PTA Concert Toms
with T-2000 Tom Stands

FEATURES

- 6 ply African Mahogany
- 2.3 mm SuperHoop II Rims
- Single or Double Headed Models Available
- OptiMount Mounting System on Double Head Series
- I.S.S. Mounting System on Single Headed Series
- Renaissance Ambassador Heads
- Stands Sold Separately
- Lifetime Warranty
- * Available in #210 Matte Walnut Lacquer

SIZES

	Dbl Headed	Sgl Headed	Size
	PTA-0608D	PTA-0608S	6" x 8"
	PTA-0808D	PTA-0808S	8" x 8"
	PTA-1010D	PTA-1010S	10" x 10"
	PTA-1210D	PTA-1210S	12" x 10"
	PTA-1311D	PTA-1311S	13" x 11"
	PTA-1412D	PTA-1412S	14" x 12"
	PTA-1514D	PTA-1514S	15" x 14"
	PTA-1614D	PTA-1614S	16" x 14"



OptiMount



I.S.S. Mount
U.S. Patent #5544561

PHILHARMONIC CONCERT BASS

Philharmonic Concert Bass Drums offer unprecedented bass response. The naturally warm frequency response of the 6 ply African Mahogany shells provide a deep warm resonance ideal for concert use. Strong 2" maple hoops and completely insulated die-cast claws provide optimal tuning with the Silent Tension Lug system. This series of bass drums features Remo Nuskyn® heads designed to promote a dark, warm sound with extended sustain.

FEATURES

- 6 ply African Mahogany
- Remo Nuskyn® Heads
- Silent Tension System
- Low Mass Lugs
- 12 8mm T-Handle Tuning Bolts
- 2" Wide Maple Hoops
- Lifetime Warranty
- * Available in #210 Matte Walnut Lacquer

SIZES

PBA-2814	28" x 14"
PBA-3216	32" x 16"
PBA-3616	36" x 16"
PBA-3618	36" x 18"



Silent Tensioning

Pearl's Silent Tensioning System utilizes low mass quiet lugs and ergonomically designed tuning keys featuring 8mm T-Handle Tuning Bolts for optimal leverage and tuning ease.



PBA-3618
Shown on STBD-36 Stand



SYMPHONIC SNARE DRUMS



SYP-1465
#138 Antique Sunburst

SYP-1455
#138 Antique Sunburst

Symphonic Snare Drums are a highly versatile instrument for the modern performer. Developed exclusively for the concert hall these drums feature shell construction of 6 ply Maple in a choice of 2 shell depths, 6.5" and 5.5".

The SR-300 Multi-Timbre Snare Strainer System functions as 3 individually controlled throw-offs, allowing for 7 snare combinations to fine tune your sound to the music. The Multi-Timbre strainer allows individual control over tension and positioning of each snare strand material stainless, coated cable, and wire.

FEATURES

- 6 Ply 7.5mm Maple Shell
- Multi-Timbre Snare Strainer
- 3 Snare Materials:
Coated Cable, Stainless, & Wire
- Die Cast Hoops & Tube Lugs
- Remo Renaissance Diplomat Heads
- Lifetime Warranty

SIZES

SYP-1455	14" x 5.5"
SYP-1465	14" x 6.5"

* Available in #138 Antique Sunburst



SYMPHONIC SERIES TOMS

Today's music requires instruments with power, projection, and fullness of sound. Today's percussionist demands instruments that have a tonal quality that can be used in the studio for the most delicate passages, powerful enough to be heard at the back of the stadium if needed, and durable enough to last on the road. Pearl Symphonic concert toms do all that with the best hardware on the market to back it up.



PTM Concert Toms
Single Headed Version

FEATURES

- 6 ply Maple
- 2.3 mm SuperHoop II Rims
- Single or Double Headed Models Available
- OptiMount on Double Headed Toms
- I.S.S. Mounting on Single Headed Toms
- Renaissance Ambassador Heads
- Lifetime Warranty
- * Available in #201 Matte Walnut Lacquer Finish

SIZES

DbI Headed	Sgl Headed	Size
PTM-0608D	PTM-0608S	6" x 8"
PTM-0808D	PTM-0808S	8" x 8"
PTM-1010D	PTM-1010S	10" x 10"
PTM-1210D	PTM-1210S	12" x 10"
PTM-1311D	PTM-1311S	13" x 11"
PTM-1412D	PTM-1412S	14" x 12"
PTM-1514D	PTM-1514S	15" x 14"
PTM-1614D	PTM-1614S	16" x 14"



OptiMount



I.S.S. Mount
U.S. Patent #5544561

SYMPHONIC BASS DRUM

Symphonic Series Concert Bass drums provide a solid resounding bass tone with size options that will expand your understanding of what a bass drum can do. 100% Maple shells are the primary material used in concert percussion because of its well balanced tonal response and sustain.

FEATURES

- 6 ply Maple
- Silent Tension System
- Remo FiberSkyn II Heads
- Low Mass Lugs
- 12 8mm T-Handle Tuning Bolts
- Lifetime Warranty
- * Available in #201 Matte Walnut Lacquer Finish

SIZES

PBM-2814	28" x 14"
PBM-3216	32" x 16"
PBM-3218	32" x 18"
PBM-3616	36" x 16"
PBM-3618	36" x 18"
PBM-3620	36" x 20"
PBM-3626	36" x 26"

PBM-3626
Shown on CBS-80M Stand



TOM SHERWOOD
ATLANTA SYMPHONY
ORCHESTRA

SR-300 SNARE STRAINER

The Multi-Timbre Snare Strainer provides quick access to each of the three separately adjustable throw-offs. Each lever controls separate snare assemblies providing seven possible snare combinations. Complete snare tension adjustment is fine tunable via the three individual knobs for a vast range of aural coloring.



JAMES BABOR
LOS ANGELES
PHILHARMONIC

CONCERT SNARE DRUMS



CRP-1455
#102 Natural Maple



CRP-1465
#103 Piano Black

Pearl's Concert Snare Drums are packed with high-end features at a price that makes them an outstanding value. Available in 2 sizes, these drums offer many of the features of our flagship models but at a cost any drummer can afford. These drums feature 6 ply all Maple construction, Tube lugs, SuperHoop II rims and Pearl's time proven SR-017 strainer that utilizes special Duo-Wire Snare with 7 Strands of Thin Yellow Cable and 7 Strands of Stainless Steel Cable.

FEATURES

- 6 ply Maple Shell Construction
- Vintage Tube Lugs
- SR-017 Strainer
- 2 Snare Materials:
7 Strands of Thin Yellow Cable
& 7 Strands of Stainless Steel Cable
- SuperHoop II Rims
- Remo Renaissance Heads
- Lifetime Warranty

SIZES

CRP-1455	14" x 5.5"
CRP-1465	14" x 6.5"

* Available in #102 Natural Maple
or #103 Piano Black



SR-017 DUO WIRE

Coated Snare Cable and Stainless Steel Snare Cable are uniquely angle mounted together on a single SR-017 Snare Strainer to emulate graduated tension, and to provide both excellent volume and extreme sensitivity while maintaining a constant, full-bodied orchestral snare timbre.

CONCERT SERIES TOMS

Pearl's Concert Series Concert Toms offer a wide range of tuning and performance possibilities. From Concert Hall to Stadium, superb tone and excellent projection can be achieved from our new 6 ply composite shells of durable Poplar and full sounding Kapur cut in full size depths.



PTE Concert Toms

FEATURES

- 6 ply Poplar / Kapur
- 1.6 mm Steel Hoops
- Available in 4 Sets or 8 Individual Sizes
- Sets include T-890 Double Tom Stand
- Lifetime Warranty
- * Available in #46 Midnight Black Covering

SIZES

PTE-0608	6" & 8" Toms w/ Dbl Tom Stand
PTE-1012	10" & 12" Toms w/ Dbl Tom Stand
PTE-1314	13" & 14" Toms w/ Dbl Tom Stand
PTE-1516	15" & 16" Toms w/ Dbl Tom Stand



Steel Hoops

T-890

CONCERT BASS DRUM

Concert Series Bass Drums have the dynamic projection and extreme volume needed for general concert use, and the perfect choice for field or stadium performances. The PBE shell construction has been upgraded to 6 plies of full sounding Kapur, a hardwood generally reserved for only high end products. Available in 4 sizes and finished in #46 Midnight Black covering with matte black Maple hoops.

FEATURES

- 6 ply 7.5mm Kapur shells
- Key Bolt Tension Rods
- Steel Claws
- Matte Black Maple Hoops
- * Available in #46 Midnight Black Covering

SIZES

PBE-2814	28" x 14"
PBE-3216	32" x 16"
PBE-3616	36" x 16"
PBE-3618	36" x 18"



PBE-361646
Shown with STBD-36F Stand



ACADEMY SERIES XYLOPHONE & MARIMBA



The Academy Series instruments feature a patent pending Integrated Resonator Rail System that provides not only a quality bar suspension and box resonator format, but also the rigid Aluminum Beam structure that makes these instruments the most durable in this class. Academy series keyboards can be used on a table-top, or with the double leg X-style stand. A carry handle is provided to make transport easy and soft cases are available separately. Academy Series keyboards feature the same hand-adjusted bar tuning methods as the top of the line Artist Series instruments and include a pair of mallets and drop cover.



CSMBSA30
MARIMBA SOFT CASE
W/ WHEELS

CSXFSA35
XYLOPHONE SOFT CASE
W/ WHEELS

New form fitting padded bags with wheels are now available separately for each Academy model.



The Xstand adjusts to 3 playing heights and locks securely into place to safely cradle the instrument.



Aluminum rail construction.



Carry handle.

ADAMS ACADEMY SERIES KEYBOARD INSTRUMENTS

The Academy series instruments bring a new level of accessibility and quality to the playing experience of young players. Now everyone can have a high quality wooden bar instrument at an affordable price to maximize the learning experience at an early level.

EDUCATIONAL KITS

The perfect start to a career in percussion begins with high quality instruments. Pearl Educational Kits contain superior components that are fast and easy to assemble. The components of each kit store away for easy transport in their own custom made carrying case. The 900 Series Cases have been made more durable with reinforced handles, added pouches, and more compact size.

PERCUSSION LEARNING CENTER

- PL-900C**
- 13" x 3.5" Wood Snare Drum
 - Wheeled, Rolling Nylon Case
 - 2.5 Octave Bells (F5-C8)
 - 8" Tunable Practice Pad
 - Quick Release On/Off Bell and Practice Pad Stand
 - Includes Snare Basket
 - Music Rack
 - Bell Mallets
 - Snare Drum Sticks
 - Retractable Handle



PL-900C

SNARE KIT

- SK-900C**
- Wheeled, Rolling Nylon Case
 - 14"x5.5" Steel Snare Drum
 - 14" Gladstone Style Practice Pad
 - Heavy Duty Snare Stand
 - Snare Drum Sticks
 - Also available as SK-900 with a Backpack Style Case



SK-900C

PERCUSSION KIT

- PK-900C**
- Wheeled, Rolling Nylon Case
 - 2.5 Octave Bells (F5-C8)
 - 8" Tunable Practice Pad
 - Quick Release On/Off Bell and Practice Pad Stand
 - Music Rack
 - Bell Mallets
 - Snare Drum Sticks
 - Also available as PK-900 with a Backpack Style Case

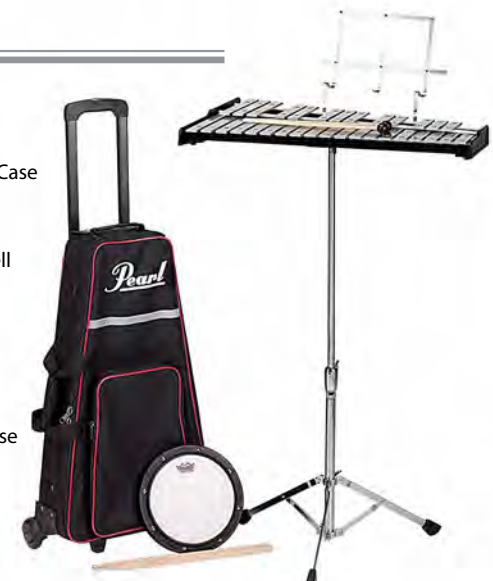

PK-900C

SNARE STANDS

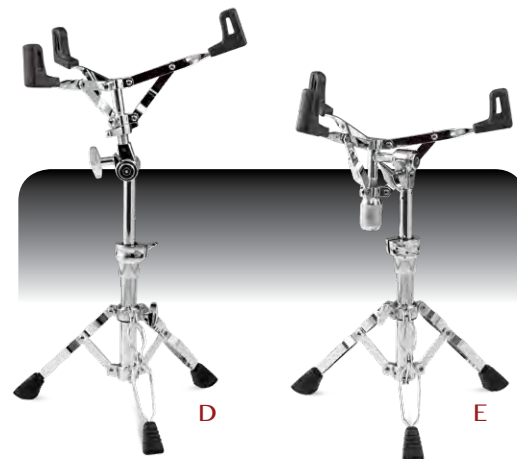
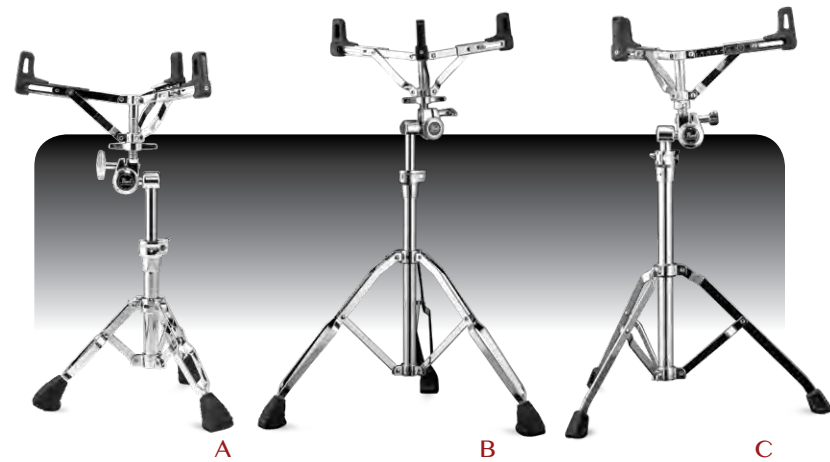

S-1030 Snare Stand GyroLock
Infinitely Adjustable Drum Positioning



S-1030 Snare Stand Basket
Fits 10" - 16" Snare Drums

Our premier S-1030 model features Pearl's 360 degree infinitely adjustable GyroLock tilter for ease-of-use and pinpoint positioning. The basket arms adjust to fit snares from 10" to 16" while promoting optimal resonance with Pearl's patented (U.S. Pat. #6710236) Air Suspension Tips. The S-930 and S-930D (with drop basket) offers similar features but uses our legendary Uni-Lock infinitely adjustable tilter.

	A S-1030	B S-1030L	C S-1030LS	D S-930	E S-930D
BASKET	10" - 16" Drums	10" - 16" Drums	10" - 16" Drums	13" - 14" Drums	13" - 14" Drums
TILTER	GyroLock	GyroLock	GyroLock	Uni-Lock	Uni-Lock
ARM TIPS	Air Suspension Rubber Tips	Air Suspension Rubber Tips	Air Suspension Rubber Tips	Air Suspension Rubber Tips	Air Suspension Rubber Tips
LEGS	Double Braced Legs*	Double Braced Legs	Single Braced Legs	Double Braced Legs	Double Braced Legs
LEG TIPS	18.5" - 25.98"	27.32" - 34.84"	26.38" - 33.85"	18.11" - 25.59"	14.57" - 21.65"

*CVT-300 /3 Spike Feet Ready

TOM STANDS

Pearl's Advanced Hardware offers positioning possibilities never before attainable. Our 1030 Series features our GyroLock tilter for an infinite 360 degree range of movement. The 930 Series use our Uni-Lock tilter for 180 degrees of motion. Our 830 Series use our dependable gear tilter.



T-1030 Hinged Collar on the Trident Tripod

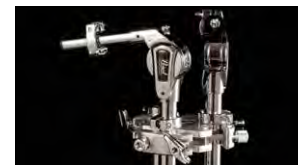

T-930 Uni-Lock Tom Holders



	T-1030	T-930	T-830
TILTER	GyroLock	Uni-Lock	Gear
PIPE JOINT	Hinged w/ Stop-Lock	Hinged	Direct Pressure
TUBES	No Rattle Tubes	Standard	Standard
FASTENERS	UltraGrip Wingnuts & Wingbolts	UltraGrip Wingnuts & Wingbolts	UltraGrip Wingnuts & Wingbolts
FEET	Extra-Large No-Slip	Large No-Slip	Standard No-Slip

CYMBAL STANDS

Pearl is the choice of the serious working drummer. We've been advancing drum hardware since 1946 so if you're serious about drumming, get serious about your hardware. Our C-1030 features top-shelf features like a GyroLock tilter, patented (U.S. Patent #7176368) WingLoc Quick Release Wing Nut, patented (U.S. #6940006) Reversible Seat Cup, and Trident Tripod for the ultimate in professional grade performance.

The C-930's Clamshell design provides superhuman clamping force. Set your position, lock it down and wail away.

The C-830 offers lighter weight while incorporating many of the 1030 series designs. Large, easy-to-use wingnuts and lateral struts ensure optimal stability.



	C-1030	C-930	C-830
CYMBAL TILTER	GyroLock w/ Wing-Loc	Uni-Lock	Uni-Lock
PIPE JOINT	Hinged	Hinged	Direct Pressure
TRIPOD	Hinged Trident Tripod	Trident-Design Tripod	Double Braced Tripod
PIPES	1-1/8", 7/8", 5/8"	1-1/8", 7/8", 5/8"	1", 7/8", 5/8"



JEREMY BRANSON
Pittsburgh Symphony Orchestra



RICHARD WEINER
Cleveland Institute of Music



ANDY HARNBERGER
Lee University



JONATHAN OVALLE
University of Michigan



JULIE HILL
University of Tennessee at Martin



ROGER SCHUPP
Bowling Green State University



WILLIAM HUDGINS
Boston Symphony Orchestra



JOHN KINZIE
Colorado Symphony



DAVID FISHLOCK
Cincinnati Symphony Orchestra



MICHAEL WERNER
Seattle Symphony



TIMOTHY ADAMS
University of Georgia



JIM ATWOOD
Louisiana Philharmonic



CYNTHIA YEH
CHICAGO SYMPHONY ORCHESTRA

TIMPANI THRONE

Pearl's Timpani Throne provides a new standard of stability and adjustability. Featuring a hydraulic adjustable seat, the throne can be positioned between heights of 23"-33". In combination with the seat, the D-3000TC also has an adjustable leg rest to ensure comfort. The throne also has extendable feet that can adapt to uneven floors.

D-3000TC



CONCERT CYMBAL STANDS

The C-1000SC Goose Neck Cymbal Stand allows the suspension of any cymbal ready for striking. The stand adjusts for height and has single braced legs. The C-1000AC Orchestral Cymbal Cradle holds 2 cymbals with quick access. Rubber coated cradles maintain quiet during retrieval and replacement.

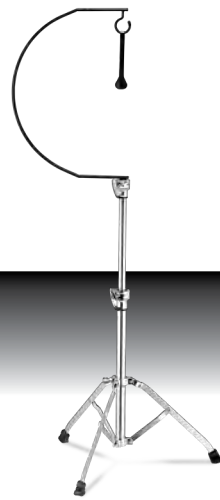

C-1000SC



C-1000AC

BASS STANDS

Pearl offers the most complete selection of Bass Drum Stands on the market. Ranging from an adjustable cradle, to a direct mount, to the professional standard suspended stand, there is a solution for any need.

CBS-15

Folding Bass Stand

- Lightweight
- Adjustable to Drum Size
- Multi Position Braces
- Rubber Pads on Frame Cross Bars



STBD

STBD Suspended Bass Stand

- Steel Frame Construction
- 360 Degree Angle Adjustment
- Rubber Web Suspension
- Full Length Foot Rest Bar
- Angle Adjustment Locking Handle
- 3" Double Locking Casters
- 4 Sizes (28", 32", 36", 40")

STBD-32	32"
STBD-36	36"
STBD-36F	36" w/ Field Wheels
STBD-40	40"



STBD-36F • Field 8" Pneumatic Double Locking Casters



CBS-80

Tilting Bass Stand

- Isolated Suspension Mounting System
- Super Sturdy, yet Lightweight Tube Frame
- Locking Swivel Adjustment for Drum Angle Positioning
- Four Large Easy Rolling, Lockable Wheels
- CBS-80M - for 36"
- CBS-80S - for 32"



CBS-38C

Tilting Bass Stand

- Gently Cradles Drum on Four Small Rubber Cushions
- Width Adjustable, with Foot Rest
- Angle is Adjustable with the Front Mounting Bracket
- CBS-38C Locking Casters



WILLIAM MOERSCH
University of Illinois



MARC DAMOULAKIS
Cleveland Orchestra



JAMES LEE WYATT III
San Francisco Symphony



BRAHAM DEMBAR
Indianapolis Symphony Orchestra



MATTHEW STRAUSS
Houston Symphony



CHRISTOPHER MCLAURIN
Kansas City Symphony Orchestra



CHRISTOPHER HANNING
West Chester University



GREGORY BEYER
Northern Illinois University



JULIA GAINES
University of Missouri



NEXUS

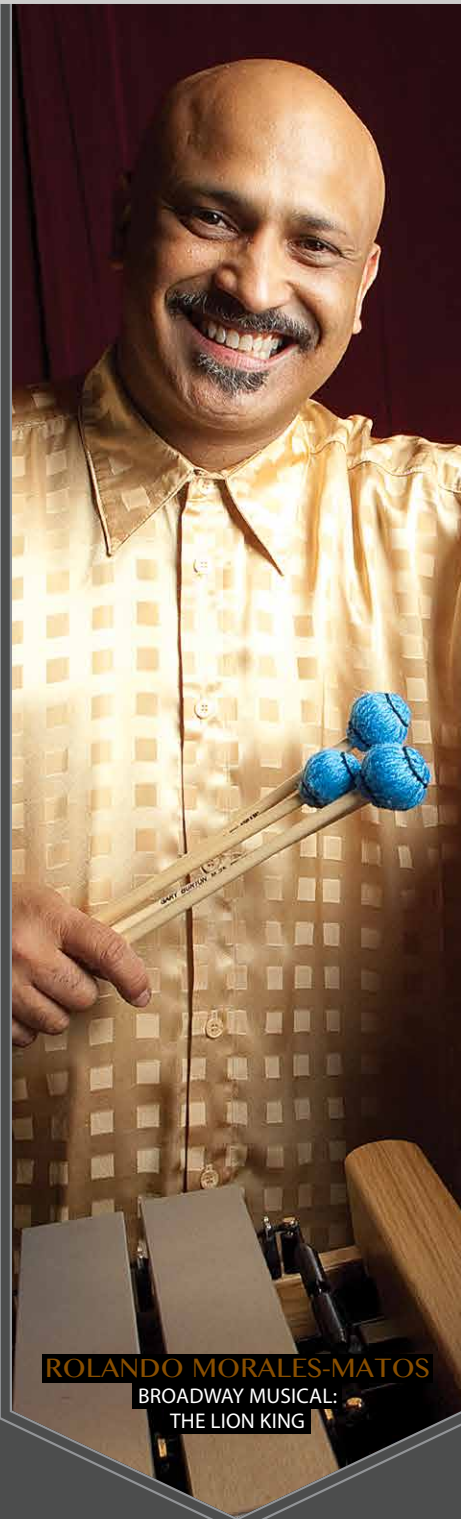

ROLANDO MORALES-MATOS
BROADWAY MUSICAL:
THE LION KING

MEEHAN PERKINS DUO

CAJONS

A Jingle Cajon
Designed by Pete Korpela, this Fiberglass Cajon features built in Platinela and tambourine jingles that can be engaged for incredible sound with fixed snares.



PCJ-629
#629 Carubinga Finish



PBC-512TF
#512 Sheer Black

B 2 Faced Cajon
This professional wood Cajon with fixed snares has a 3mm thick face for a traditional low pitch and a 5mm thick face for a distinct higher pitch.

C Boom Box Cajon
This Fiberglass Cajon with fixed snares features a built in bass port that magnifies subsonic frequencies for never-before-heard lows.
*Artisan Red Mahogany finish also available.



PCJ-633BB630
#630 Red Sparkle Finish



PBC-507
#507 Gypsy Brown Finish

D Primero Cajon
Get started with Primero. Constructed from Asiatic Pine with adjustable snares, this model has the right pitch and price.

CAJON ACCESSORIES

Pearl's line of cajon accessories allow you to enhance your performance by adding dynamic new sounds. Jingle Cups can be added to the face of any Cajon or even to acoustic guitars and other drums. The new Cajon Clave and Wood Blocks attach to your cajon using the provided 3M Dual-Lock Tape or can be played hand-held or stand mounted. The new Cajon seat cushion adds comfort for long sessions.



E PBCW-100 Wood Block w/ Dual-Lock Tape & Mounting Bracket (PPS-37 Not Included)
F PJCP-1/6 Jingle Cups Two Pack
G PBCC-100 Clave Block w/ Dual-Lock Tape & Mounting Bracket (PPS-37 Not Included)
H PSC-BC Seat Cushion w/ Thick Foam for Comfort

CONGAS, BONGOS & TIMBALES



PTC-1100 11" x 3.5"
PTC-1175 11.75" x 3.5"
PTC-1250 12.5" x 3.5"

Folkloric Elite Bongos
PWB-300FC
(7" and 8.5")



Folkloric Elite Congas
PCW-125FC Tumbadora (12.5")
PCW-110FC Quinto (11")
PCW-117FC Segundo (11.75")
#526 Crimson Sunrise

Travel Congas
3.5" Deep and Available in Three Sizes:
11", 11.75" & 12.5" • Includes Tuning Wrench • Cases & Stands Sold Separately



Richie Flores Primero Model
PWC-203RF 10"/11" Oak Conga Set
#534 Tiburon Blue
Includes PC-300W Stand



Bobby Allende Primero Model
PFC-203BA 10"/11" Fiberglass Conga Set
#642 Harbor Gray • Includes PC-300W Stand w/ Remo FiberSlyn Heads

PWB-100RF 7" / 8.5" Fiberglass Bongos
#534 Tiburon Blue

PFB-100BA 7" / 8.5" Fiberglass Bongos
#642 Harbor Gray

Timbales

Pearl's Primero Pro Steel timbales are a budget conscious timbale set packed with professional features. The heavy-duty double braced tilting stand securely supports the 14 & 15-inch steel shells that are 7 inches deep for added projection and greater cascara surface area. The cowbell mount is based off our PT-900W Timbale stand making set-up and teardown possible in seconds. Tuning wrench and sticks are included.



Elite Timbales PTB-5145
14"/15" Brass w/ Tilting Stand



Primero Pro Timbales
PTE-1415DX 14"/15" Steel w/ Tilting Stand (Cowbell Not Included)



Primero Timbales
PTS-5134 13"/14" Steel w/ Tilting Stand, Sticks & Cowbell Included



Primero Flat Timbs PTE-3131
Flat Timbale w/ L.S.S. (Steel)



Primero 13" Steel
PTE-1336 w/ PPS-36 Mount



Surdo 18" PBS-1822
Surdo 20" PBS-2018
Surdo 22" PBS-2222 (not pictured)



Legs & BD Adapter Kit for Surdo
PBS-30BD



Caixa 12" x 6.5" PBCX-1265
Caixa 12" x 4" PBCX-1204 (not pictured)



Cuica
PBC-80SS



Tamborim Stick PBT-70S
Surdo Mallet PBSM-20



Pandanza
PDZ-510 w/ Agogo Bell

Pandeiro 10"
PBP-510 (5 Sets Platinelas & Goatskin Head) w/ Bag

Pandeiro 12"
PBP-612 (6 Sets Platinelas & Plastic Head) w/ Bag



Tamborim
PBT-60C



Repinique 10"
PBR-10S w/ Strap

Repinique 12"
PBR-12S w/ Strap



HAND PERCUSSION



PERCUSSION TOY BOX

Case and Trap Tray in one! Aluminum frame mounted in lid attaches to music or cymbal stand to hold small percussion.

(Instruments sold separately)



PTYB-1212 Percussion Toy Box

CONCERT PERCUSSION



TRAP TABLE & RACK



Our popular PTT-1824 Trap Table can be easily converted into a two-level folding rack without drilling or modifications by simply adding Pearl's PTR-1824 Add-On Rack. The PTR-1824 installs in seconds using clamps and folds flush with the table for easy pack-up. A unique clamping system allows the included (4) straight and (4) angled 3/8" knurled posts to clamp anywhere onto horizontal or vertical areas of the rack. Also included is a retractable three-legged stabilizer bar for optimum stability.



PERCUSSION CASES

Pearl's padded carrying cases include features like ergonomic carrying straps, rubber protective bottoms, top-mounted carrying handles, tuning wrench pouches, and heavy duty double zippers. The PPB-100 is made from heavy weight nylon and will fit all Conga sizes.



SO PERCUSSION



WILL KENNEDY
THE YELLOWJACKETS



EXPORT FINISHES:

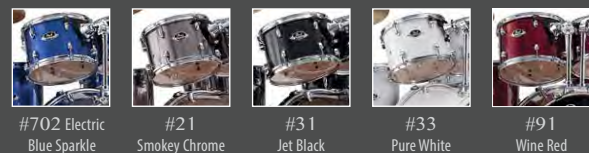

RHYTHM TRAVELER



RT-705HBCM31

Easy to transport and easy to practice, the ground breaking concept kit Rhythm Traveler is a compact gigging and practice kit all in one. This complete 5pc kit includes professional quality 2 ply "ProTone" heads and 13" and 16" cymbals for live performance, and silent mesh heads and plastic cymbals for quiet practicing. Whether you are a beginner just starting out, or a gigging drummer who needs a convenient practice set, the Rhythm Traveler is the perfect solution.

EXPORT



EXX-705/C702
#702 Electric Blue Sparkle

The #1 Selling drum set in the world is back and better than ever. Export Series is the name every drummer knows. These value packed kits jump-started thousands of drummers by bringing quality and value together. Now, 30 years later, Export does it again. Big features like Reference-inspired shell composition, P-930 drum pedal, Opti-Loc Tom Mounts, and our all new hardware package make Export the biggest value in drums today... again.

MASTERS MCX SHELL PACK

The classic, natural sound of Masters MCX Maple can best be described by one word... resonant. Our exclusively manufactured 6 ply 100% Maple shells produce the perfect blend of stunning attack, smooth midrange and low end punch that has made these drums so popular with top players in every style of music. There is simply no better choice than Masters MCX. Shell packs available in 3 stock configurations and 5 high-gloss lacquer finishes.

Configurations:

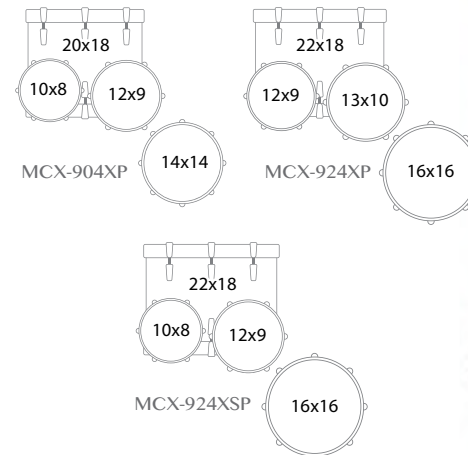

* Shown with optional Snare, Throne, Hardware and Cymbals.

MCX-924XSP/C800
#800 Quilted Bubinga Sunburst

e-PRO LIVE



EPLX-205P/B464
#464 Quilted Maple Fade















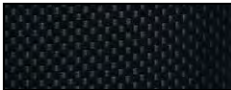

e-Pro Live is a revolutionary electronic drumset that looks, feels and sounds like real drums. The secret of the e-Pro's FEEL is its Tru-Trac Electronic Drumheads that have the same size and response as real heads which allows drummers to transition from acoustic to electronic drums with absolutely no alteration to their playing style.

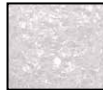

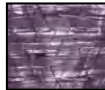



















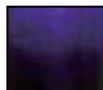

*Kit includes everything shown except drum throne

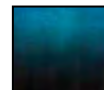
TRU TRAC ACOUSTIC TO ELECTRIC CONVERSION







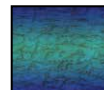









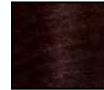



Convert any acoustic drum set to an electronic drum set as easy as changing a head with Pearl's Tru-Trac Pack and Tru-Trac Conversion Kits. Tru-Trac Packs are available in two preconfigured kits that include 4 Dual Zone Electronic Drumheads, Electronic Bass Drumhead, 5 No-Drill Adapters that port the cables through the air vents, 5 TRS Cables to connect the drums to the module and extra-long Tension Rods. Tru-Trac Conversion Kits are available in 4 configurations and each includes everything in the Tru-Trac Pack plus a r.e.d.Box Module, Cymbals, Hi-hat Controller, and Holders.

		COMPETITOR SERIES CARBONPLY SERIES Special Order Only CARBONCORE SERIES Standard Lacquer PLUS All Special Order Lacquers		CHAMPIONSHIP MAPLE Standard Wrap CHAMPIONSHIP MAPLE Special Order Wrap PLUS All Special Order Lacquers				
								
								

										
										
										
										
						50 SPECIAL ORDER LACQUERS #100 - #818 CarbonCore and Championship Maple Series Only				

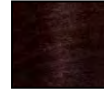
ORCHESTRAL PERCUSSION

CONCERT SNARE DRUMS						CONCERT TOMS				 pearldrumsfan  PearlDrumCorp  PearlDrumCorp  pearldrumsforum.com
										

PEARL MARCHING & CONCERT CATALOG 2014

Colors shown in this catalog are for representation only and may not be exactly the same as the original due to the printing processes involved.

Products and specifications are subject to change without notice.
 Printed in USA MCC2014



DOWNLOAD THIS CATALOG

<http://pearldrums.com/support/product-catalogs>

For more information on these and other Pearl products, visit your local authorized Pearl dealer.

