



Pearl®

2 0 2 3
GENERAL CATALOG



INSPIRATION AWAITS!

With nearly eight decades of legendary crafting history firmly cemented in the lives of countless drummers, 2023 sees Pearl advancing the drum set to unsurpassed heights. Our goal was to make the complete selection and performance aspect of drumming effortless and fuel the current of rhythmic creativity in a new generation of players. This would include an odyssey into the very foundations of drum making, from shell formation to mounting platforms, to eliminate stress and let each drum truly sing. The solution lies in reimagining the benefits of tom suspension systems on a new era of professionally catered percussion items, to showcase the sonic and visual identity of each drummer and bridge the gap between Player and Instrument.



MASTERWORKS
p. 3 - 4, 7 - 12

Custom made in your personal selection of woods, edges, sizes, and veneers.
SHELL RECIPE
Individually tailored combination of Birch, Maple, Gumwood, and/or Mahogany.
SOUND
The tonal reality of your ultimate ideal, Masterworks literally sounds like every drum set you've ever dreamed of.



REFERENCE ONE
p. 13 - 14

The ultimate ideal of the modern hybrid drum concept, all components are independently engineered for the best tonality in every quadrant of the kit.
SHELL RECIPE
EvenPly Birch, Maple, and Mahogany hybrid.
SOUND
Expressive, wide range sonic boost with enhanced bottom-end.



CRYSTAL BEAT
p. 29 - 30

The original seamless Acrylic drum shell creates a striking visual and sonic showcase.
SHELL RECIPE
Seamless molded Acrylic (Tom and Floor Tom: 6mm / Bass Drum: 7mm)
SOUND
Loud and immediate, delivers pummeling straight tone and yielding feel.



DECADE MAPLE
p. 31 - 32

Premium gear for the evolving drummer, featuring lacquered all Maple shells and pro-level elements.
SHELL RECIPE
EvenPly-Six, 5.4mm Maple
SOUND
Full maple tone with lively midrange and smooth sustain.



EXPORT
p. 33 - 34

The Best-Selling Drum Set of All Time gives the student drummer a strong beginning.
SHELL RECIPE
6-ply 7.5mm Poplar and Asian Mahogany hybrid
SOUND
Crisp attack with dark, formidable bottom-end vibrance.



MASTERS MAPLE / GUM
p. 17 - 18

Optimized for the recording studio; vital tone derived from the Masterworks: Studio shell recipe.
SHELL RECIPE
EvenPly-Six Maple (4-ply outer) and Gumwood (2-ply inner)
SOUND
Explosive midrange tonality with full low-end and precise decay.



MASTERS MAPLE
p. 19 - 20

Three decades of Masters excellence is reimagined with our history-making 6-ply Maple shell and a host of massive upgrades.
SHELL RECIPE
7.5mm 6-ply Premium Maple.
SOUND
Attack and projection with smooth, full-bodied resonant attack.



MASTERS MAPLE PURE
p. 21 - 22

Pearl's original premium MMX shell formula delivers near-field resonance and sharp top-end attack for varied pro environments.
SHELL RECIPE
5mm 4-ply Premium Maple w/4-ply Reinforcement Rings.
SOUND
Balance of powerful midrange and smooth resonant attack.



MIDTOWN
p. 35

An ultra-portable shell pack for full-sized play and powerful grooves in a small footprint.
SHELL RECIPE
6-ply 7.5mm Poplar
SOUND
Tight, responsive tonal bite with enough bottom to fill the pocket.



ROADSHOW
p. 36

A drum set package complete with everything needed to kickstart your rhythmic journey.
SHELL RECIPE
9-ply 7mm Poplar
SOUND
Piercing, open cut with the right amount of sub-bass rumble to keep you inspired.



PROFESSIONAL SERIES
p. 23 - 24

A gig-friendly workhorse derived from our classic MLX Series that's excellent for independent touring.
SHELL RECIPE
EvenPly-Six, 5.4mm North American Maple
SOUND
Equal parts Low/Mid/High frequency punch with smooth, extended decay.



SESSION STUDIO SELECT
p. 25 - 26

Radically unique Studio blend with pre-EQ'd warmth and cutting, articulate strike.
SHELL RECIPE
EvenPly-Six Birch (4-ply outer) and African Mahogany (2-ply inner)
SOUND
Deep, rich bass frequencies combined with top-end tonal drive.



PRESIDENT SERIES DELUXE
p. 27 - 28

Dark, dry vintage spread with the classically controlled "MJ Sound".
SHELL RECIPE
6-ply, 7.5mm Lauan.
SOUND
A slick, sonic locomotive of subdued, vintage punch with singular low-range overtone.

2023 GENERAL CATALOG

| | | | |
|-------------------------------|-----------------------------|--------------------------------|---|
| DRUM SETS | SNARE DRUMS | HARDWARE | PERCUSSION |
| 3-4,7-12 Masterworks | 37-38 Music City Custom | 55-56 Demon XR | 75 Percussion Artists |
| 5-6 R2 Air Suspension System | 39-41 Series Component | 57 Demon Drive | 76 Signature Series |
| 13-14 Reference One | 42 Free Floating | 58 Demon Chain | 77-78 Congas & Bongos |
| 15-16 Masters Introduction | 43 SensiTone Heritage Alloy | 59-60 Eliminator Redline | 79-80 Travel (Congas, Bongos, Timbales) |
| 17-18 Masters Maple/Gum | 44-46 Signature | 61-62 Eliminator Solo | 79 Timbales |
| 19-20 Masters Maple | 47 Hybrid Exotic | 63-64 P930 / P932 | 80 Cowbells |
| 21-22 Masters Maple Pure | 47 UltraCast | 64 P530 / P830 | 81 Djembes |
| 23-24 Professional Series | 47 Duoluxe | 65-66 Hi-Hat Stands | 82 Folkloric / Brazilian |
| 25-26 Session Studio Select | 48 StaveCraft | 67 Snare Stands | 83-84 Cajons & Cajon Accessories |
| 27-28 President Series Deluxe | 49 Modern Utility | 68 Drum Thrones | 85 Handpans |
| 29-30 Crystal Beat | 50 Effects | 69-70 Cymbal Stands | 86 Tongue Drums |
| 31-32 Decade Maple | ELECTRONIC SERIES | 71-72 Racks | 87 Rainsticks / Nut Shakers |
| 33-34 Export | 51-52 e/MERGE | 73 Rack Accessories | 88 Concert Percussion |
| 35 Midtown | 53 MIMIC PRO | 74 Tom Stands | 89-90 Hand Percussion |
| 35 Rocket Toms | 54 malletSTATION | 74 Tom Arms | 91 Percussion Stands |
| 35 Compact Traveler | | | 92 Bags & Holders |
| 36 Roadshow / Roadshow Jr. | | | |
| 93-96 Replacement Parts | 97-100 Pearl Artists | 101-BACK Config. & Color Chart | 104 Warranty Info |



Completely Custom, Totally Handmade

HANDCRAFTED FOR GREATNESS

Masterworks is the realization of your ultimate drum set vision. Every aspect of the kit is curated by you and built to your exacting specifications.



EXPLORE. CREATE. INSPIRE.

Masterworks begins with your choice of our finest hand selected shell veneers and precision engineered premium hardware appointments. Choose your own combination or one of our Sonic-Select Shell recipes to customize a sound and look that is completely your own.

MASTERWORKS SONIC-SELECT URBAN RECIPE
NATURAL WALNUT BURST BUBINGA AND ROSETTE INLAY

DRUM SHELL TONE WOODS

Choose one or a combination of our premium shell materials to sculpt the sound of each drum.



MAPLE
Tonally equal in highs, mids, and lows for prime, full bodied attack and sustain.

BIRCH
Boosted attack with "Built-in EQ" for articulate and evenly reduced decay.

AFRICAN MAHOGANY
Dark, elegant tone with powerful bottom-end emphasis.

GUMWOOD
As a core or interior ply, Gum enhances tone in surrounding plies.

CUSTOM INTERIOR
Choose any of Pearl's Artisan Exotic veneers, carbon fiber, or hand applied fiberglass for boutique tones and visuals.

SHELL SIZE AND THICKNESS

For precise tonal character, sustain, and projection.



THIN (4-ply, 5mm w/ 4-ply Reinforcement Rings) Increased sustain and low-end.

MEDIUM (Even 6-Ply, 5.4mm) Expanded tonal purity and resonant punch.

STANDARD (6-ply, 7.5mm) Full-bodied tonal projection ideal for general purpose.

THICK (8-ply, 10mm and 10-ply, 12.5mm) Maximum projection and quick decay.

FINISHES

Craft an inspired visual statement with drums hand finished and configured to your specifications.

LUXURY
Includes a choice of High Gloss, Satin Stain, and Sparkle Lacquer.

CUSTOM
Includes Pinstriping, Banding, Artisan II Custom Graphics.

ARTISAN
Choose from a selection of Exotic veneers (below) or hand applied Carbonply.

CUSTOM INLAY
Accentuate the natural beauty of the outer shell finish with inlay bands inserted by hand.



CAMEROON BLACK LIMBA

FLAME MAPLE

AFRICAN ZEBRA WOOD

TAMO ASH

BUBINGA

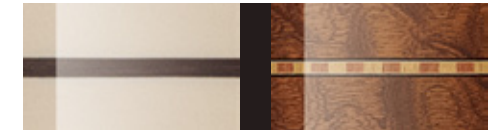

BARNWOOD

MOSAIC

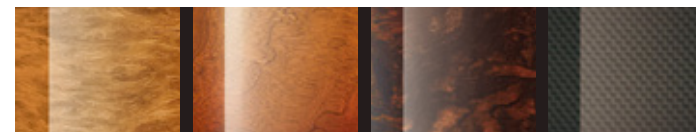

EUCALYPTUS

BURL MAHOGANY

IMBUIA

CARBONPLY

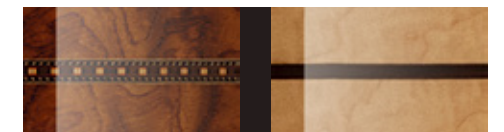

ROSETTE

EBONY

BEARING EDGE

Masterworks offers a choice of five sonically tested edges - configurable by drum, application, and shell side.



STANDARD 45°
Provides the perfect blend of attack and warmth.

OUTER 60°
Pulls brighter overtones and increases punch.

INNER 45°
Edge apex focused to inner shell plies for controlled sustain.

ROUNDED 45°
Increased head-to-shell contact boosts mids and highs.

FULLY ROUNDED
Boosts mid-to-low range response and reduces decay.

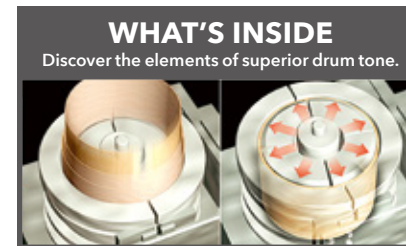

THE EST DIFFERENCE - The Ultimate in Strength, Resonance, and Tone.
Superior Shell Technology

To craft multi-ply, bonded drum shells with single-ply resonance and strength, Pearl pioneered the world's first high temperature hydraulic curing system. SST shells are formed in a bonded combination of cross-laminated

2-ply veneer panels then precision milled with overlapping scarf joint seams and cured with our exclusive AcoustiGlue at 1000 PSI of hydraulic pressure.

HARDWARE FINISH, LUG, AND HOOP OPTIONS

A choice of five plating options comes standard on your selection of our precision tuning lugs, hoops, and drum hardware.



CHROME
(Shown w/ CL100 Lug)

NICKEL
(Shown w/ STL100 Lug)

BLACK NICKEL
(Shown w/ STL150 Lug)

GOLD
(Shown w/ STL150 Lug)

BLACK CHROME
(Shown w/ STL100 Lug)

LUGS

- Bridge (CL100)
- Single Swivel (STL100)
- Swivel Tube (STL150)



HOOPS

MASTERCAST

2.3mm SUPERHOOP II



TOM MOUNT (U.S. Patent #11640814)

FOR 12.7mm VERTICAL ROD

FOR 7/8" HORIZONTAL PIPE

R2 AIR

SUSPENSION SYSTEM

TOTALLY BALANCED,
TONALLY UNITED,
FLOATING TOM SUSPENSION



THE EVOLUTION OF TOM MOUNTING TAKES A GIANT LEAP FORWARD.

The physics of drum resonance is about to meet its match. For the first time, totally unrestricted, fully uninhibited, tonally uncolored sound can be drawn from mounted toms, with the Pearl R2 Air Tom Suspension system. U.S. Patent #11640814

Elevate the Physics - and Sound - of Your Drum. R2 Air improves the overall tone of the complete drum kit by delivering the true sound of each mounted tom by creating a transition bridge from toms to floor toms.

ROCK SOLID, TOTALLY FLEXIBLE TOM POSITIONING.

Pearl is the first drum maker to offer a choice in tom mounting function. The GyroLock gearless positioning system offers the option of vertical placement with a 12.7mm solid L-arm, and the horizontal framing of our traditional 7/8" tube mount. Both offer infinite angle adjustment with a simple turn of the key without compromising sound or security. Unlike other L-arm holders that rely on a limited position, fallible ball-in-socket system, GyroLock's internal locking system can secure any angle without parts that wear over time.



R2AL
FOR 12.7mm VERTICAL ROD



R2AS
FOR 7/8" HORIZONTAL PIPE



MASTERWORKS SONIC-SELECT STUDIO RECIPE
IN NATURAL FLAME MAPLE
FEATURING
R2 AIR / GYROLOCK-L COMBINATION

MASTERWORKS SONIC-SELECT STUDIO RECIPE
IN NATURAL FLAME MAPLE
FEATURING
R2 AIR / GYROLOCK STANDARD
PIPE COMBINATION

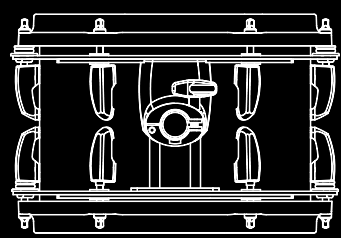

U.S. Patent #11640814

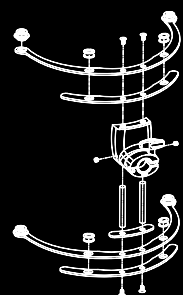

EXCLUSIVE FOUR-POINT FLOATING ISOLATION PLATFORM.

To attain tonally true sound, every drum would have to be mounted in a floating point at the center of its shell. R2 Air equally balances mounting pressure across two floating points at the top and bottom of each tom. This gives true tonal separation from mounting hardware and enhances sonic output. All mounting hardware is isolated from the shell via the R2 Air's four ResoDisk shock absorption inserts.

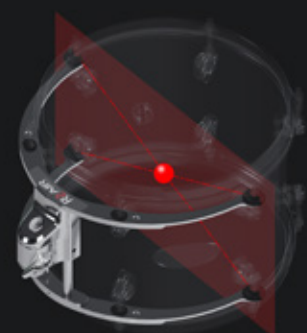

DamperDisk

Sustain and tone can even be fine-tuned with the addition of its included rubber DamperDisk in one of four tension points. This shortens decay for a more pronounced note.



MEMORY, WHERE YOU NEED IT MOST

GyroLock-L's position settings can be locked in place with the aid of additional memory locks in three separate places. This, plus our new Compass Dial markings, assure teardown and reset that is quick, secure, and repeatable. (Patent Pending)





Sonic-Select Shell Recipes

STUDIO

MASTERWORKS SONIC-SELECT STUDIO RECIPE SHELLS
IN GLOSS RED/BLACK FADE WITH BLACK NICKEL HARDWARE
AND ADDED TOP-TUNED DJEMBE (PBJV14685)



SONIC-SELECT SHELL RECIPES

CHOOSE YOUR ARENA. CREATE YOUR DREAM. DEFINE YOUR SOUND.

Our Sonic Select Shell Recipes narrow the nearly endless scope of Masterworks choice down to five sonically proven shell and hardware combinations. Each recipe is individually primed for its distinct performance environment.

STUDIO

Explosive tonal clarity and articulation for recording.

SHELL: EvenPly-Six (5.4mm) Maple/Gumwood w/ Outer 60° Bearing Edge

STADIUM

Pearl's thick CZX Maple shell for high-volume power.

SHELL: Fl.Toms/Bass: 10-ply Maple w/ Outer 60° Bearing Edges. Toms/Snares: 8-ply Maple w/ Outer 60° Bearing Edges

URBAN

A thin, powerful blend for the precise metropolitan drummer.

SHELL: Toms/Bass: EvenPly-Six Birch/Gumwood/Birch (5.4mm) with 4-ply Maple Re-Rings and mixed Bearing Edges

HERITAGE

Classic drum feel with enhanced lows and fat top-end slap.

SHELL: 4-ply Maple/Mahogany w/ 4-ply Maple Re-Rings w/ Standard 45° Bearing Edge

MODERN DRY

Quick, top-heavy articulation with controlled low-end.

SHELL: 4-ply Maple/Gumwood w/ 4-ply Mahogany Re-Rings w/ Inner 45° Bearing Edges

CUSTOMIZED TO FIT YOUR CREATIVE VISION.

Like a blank canvas for your drumming ideal, modify any Sonic-Select Shell Recipe shell or hardware option to give it your own spin or use our exclusive Artisan II process to embed your choice of high definition graphics directly onto the outer shell.

SEE www.pearldrums.com/masterworks
FOR FULL DETAILS

STUDIO

| | |
|--------------|--|
| SHELL | EvenPly-Six (5.4mm), 4-ply Maple Outer with 2-ply Gumwood Inner |
| BEARING EDGE | Outer 60° |
| HOOPS | MasterCast Hoops |
| LUGS | CL Bridge Lug CL100 (Toms) CL250 (Bass Drum) |
| SPURS | SP330 |
| FT BRACKETS | LB75 |

A POWERFUL SONIC FOUNDATION TUNED FOR THE RECORDING ENVIRONMENT.

This commanding shell/edge combination of hard exterior and milder tone woods yields explosive midrange projection and extended low end punch.



SHELL
Thin, resonant combination of a hard exterior with milder tonewood for explosive low-range warmth.



BEARING EDGE
Outer 60°
Gives increased power and bite to a thinner hybrid shell.



HOOPS
MasterCast Hoops. Escalates weight for tonal body. Increases volume in high velocity play.



LUGS
CL Bridge Lug
A classic look with minimal shell contact for precise vibration control.



Sonic-Select Shell Recipes

STADIUM

URBAN

A FRESH SONIC DRUM BLEND FOR THE METROPOLITAN PLAYER.

From sold out tours to sanctuary halls, the tonal dichotomy of three proven hardwoods projects with a defiant top end and fills the bass frequencies with thunderous, shaking lows.

URBAN

| | | | | |
|--------------|---|-------------|---------------------|-----------------------|
| SHELL | EvenPly-Six (5.4mm Toms/Bass) | HOOPS | 2.3mm SuperHoop II* | |
| | 2-Birch/2-Gumwood/2-Birch with | | LUGS | STL Swivel Tube Lugs* |
| | 4-ply Maple Re-Rings | | | STL150* (Toms) |
| | 8-ply Snare Drums | | | STL300* (Bass Drum) |
| BEARING EDGE | 2 Birch/4 Gumwood/2 Birch | SPURS | SP330 | |
| | Rounded 45° on Toms | FT BRACKETS | LB75 | |
| | Fully Rounded edge on Bass Drums Standard 45° on Snare Drums | | | |

*Recommended



STADIUM

| | |
|--------------|-----------------------------|
| SHELL | 10-ply Maple BD & FT |
| | 8-ply Maple Toms and Snares |
| BEARING EDGE | Outer 60° |
| HOOPS | 2.3mm SuperHoop II* |
| | CL Bridge Lug |
| LUGS | CL100 (Toms) |
| | CL250 (Bass Drum) |
| SPURS | SP330 |
| FT BRACKETS | LB75 |

*Recommended

THE CZX SOLUTION FOR HIGH VOLUME, RHYTHMIC COMMAND.

Pearl's legendary high density CZX Maple shell is reborn! Our classic 10-ply /8-ply shell combination delivers penetrating volume, articulate midrange attack, and focused low end.



MASTERWORKS SONIC-SELECT STADIUM RECIPE SHELLS IN SATIN NATURAL ARTISAN BURL MAHOGANY FINISH WITH MOSAIC INLAY AND GOLD HARDWARE

MASTERWORKS SONIC-SELECT URBAN RECIPE SHELLS IN VIVID BLUE OYSTER LACQUER WITH BLACK NICKEL HARDWARE



SHELL
A thick shell for dominating volume and articulate attack.



BEARING EDGE
Outer 60°
Increases brightness and power with controlled overtone.



HOOPS
2.3mm SuperHoop II Hoops - Made to withstand heavy play while allowing the shell to breathe.



LUG
CL Bridge Lugs
Heavier weight increases attack and assures the ultimate in tuning integrity.

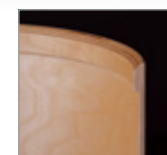

SHELL
Dense, thin shell hybrid for precise punch and quick, even decay.



BEARING EDGE
Rounded 45° on Toms (Fully Rounded edge on Bass Drums, Standard 45° on Snare Drums).



HOOPS
2.3mm SuperHoop II Hoops - Made for heavy play without limiting tuning range performance.



LUG
STL Swivel Tube Lug
A medium-weight lug with pivoting tension casing for increased projection and reduced overtone.

HERITAGE

MODERN DRY



(Masterworks Heritage Kit not shown)

| HERITAGE | |
|--------------|--|
| SHELL | Maple 2-ply outer Mahogany 2-ply inner w/ 4-ply Maple Re-Rings |
| BEARING EDGE | Standard 45° |
| HOOPS | 2.3mm SuperHoop II Hoops* |
| LUGS | STL-100* (Toms) ST-L200* (Bass Drum) |
| SPURS | SP-330 |
| FT BRACKETS | LB-75 |

*Recommended

TIMELESS, ORGANIC TONE WITH SMOOTH LOW-END GROWL

The Heritage Recipe's robust blend of reinforced Maple/ Mahogany delivers solid midrange punch with exceptional sustain and thunderous sub bass frequencies.

| MODERN DRY | |
|--------------|---|
| SHELL | 2-ply Maple outer/2-ply Gumwood inner with 4 ply Mahogany Re-Rings |
| BEARING EDGE | Inner 45° |
| HOOPS | MasterCast Hoops* |
| LUGS | Single Swivel Lugs STL-100 (Toms) STL-200 (BD) |
| SPURS | SP-330 |
| FT BRACKETS | LB-75 |

*Recommended

DARK NATURAL PUNCH FOR DRIVING, ORGANIC BEAT MAKING.

The Modern Dry Recipe blends three sonically unique tone woods for dark, controlled tone, and pillowy response. Its unique blend of shell and hardware elements adds bottom end focus and throaty punch.

MASTERWORKS SONIC-SELECT MODERN DRY RECIPE SHELLS WITH ADDED ROCKET TOMS IN #109 ARCTIC WHITE LACQUER FINISH



SHELL
A traditional blend of midrange punch and boosted low-end.

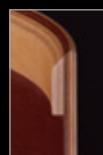

BEARING EDGE
Standard 45° - Precise, low-contact edge for added projection and resonance.



HOOPS
2.3mm SuperHoop II Hoops - Made to withstand heavy play while allowing the shell to breathe.



LUG
CL Bridge Lugs
Our lightest and most efficient tuning lug reduces hardware contact and weight on the shell.



SHELL
A unique blend of yielding tone woods and rigid exterior for added bottom-end focus.



BEARING EDGE
Inner 45°
Its inner shell apex contacts the head inside the shoulder for focused control in low tunings.



HOOPS
MasterCast Hoops - Gives each drum added weight for increased volume and controlled sustain.



LUG
Single Swivel Lugs
Our lightest and most efficient tuning lug for reduced shell contact.

Reference — ONE —

The Reference Legacy.
Unleashed.



A TRUE PEARL ORIGINAL, WITH A FRESH, GROOVE INSPIRING VIBE.

Where the Many Combine to Create a Singular Instrument. Building on the modern hybrid drum concept Pearl originated with Reference Series, every element in the Reference One drum set's construction is fine-tuned to deliver optimal performance. By leveraging specific woods, shell thicknesses, and bearing edges exactly where they are most sonically beneficial within a drum set, Reference One's reduced-thickness EvenPly shells are fitted with MasterCast Die-Cast hoops, for a radical combination sustain and attack. Combined with Pearl's revolutionary R2 Air Tom Suspension System, Reference One takes the hybrid drum concept to new, unprecedented heights.



R2 AIR TOM SUSPENSION SYSTEM

Suspends each drum by four unique points for optimum tone and resonance at any angle.



MASTERCAST HOOP

Escalates weight for tonal body and increases volume in high velocity play.



SWIVEL LUGS

Single Swivel Lugs are self-aligning for better tuning integrity and reduced shell stress. Their reduced profile takes up less room on the shell face, delivering better tone from each drum.

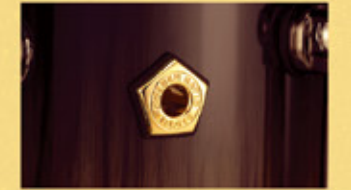

GOLDEN RATIO AIR VENT

The Golden Ratio air vent location is unique for each component size to provide enhanced tonal character and frequency response. (U.S. Patent # 7485791)



RF1C924XESPL/C
#885 Cherry Amber Fade

RF1C924XSPS/C + 14x14 Floor Tom
#393 Purple Craze II

| | |
|---------------|--|
| SHELL | Refer to Size / Shell Chart |
| SNARE | Matching 13x6.5, 14x5, 14x6.5, 14x8 |
| FINISH | CHOICE of 28 Hand-Applied Premium or Custom Lacquer Finishes |
| HEADS | Remo Coated Ambassador, Powerstroke3 Bass |
| TOM MOUNTS | R2 Air Tom Suspension system (U.S. Patent #11640814) |
| TOM ARMS | CHOICE of Pearl's Traditional 7/8" Pipe Holder or 12.7mm Solid L-Arm (Sold Separately) |
| DRUM HARDWARE | Chrome (Standard) Black nickel, |
| HOOPS | Nickel and Black Chrome (Premium Charge) |
| LUGS | Mastercast Hoops |
| BD MUFFLER | STL Single Swivel Lugs |
| | BDMF |

SHELLS

Each drum has its own custom shell, edge, and thickness profile to best suit its place in the drum set.



| REFERENCE RECIPE | SHELL TYPE | BEARING EDGE | SONIC OUTPUT |
|------------------------|---|---------------|--|
| 8" and 10" Toms | Maple(4)/Birch(2) 6-ply (5.4mm) | Rounded 45° | Cutting projection for high-note pitch |
| 12" Toms | Maple(6) 6-ply (5.4mm) | Rounded 45° | Transitional mid-note; blend of warmth and cut |
| 13" Toms | Maple(4)/Mahogany(2) 6-ply (5.4 mm) | Rounded 45° | Top-end slap with added low/bottom end |
| 14" and 15" Toms | Maple(4)/Mahogany(2) 6-ply (5.4 mm) | Fully Rounded | Bracing low-end with controlled punch |
| 16" Toms | Maple(2)/Mahogany(4) 6-ply (5.4mm) | Fully Rounded | Full, rounded sustain and gated attack |
| 14" Floor Toms | Maple(4)/Mahogany(4) 8-ply (7.2mm) | Fully Rounded | Fat, controlled low-end with smooth roll-off |
| 16" and 18" Floor Toms | Maple(2)/Mahogany(6) 8-ply (7.2mm) | Fully Rounded | Fat, controlled low-end with resonant warmth |
| 18" and 20" Bass Drums | Maple(2)/Mahogany(4) 6-ply (5.4mm) | Fully Rounded | Quick and Punchy with Powerful low-end |
| 22" and 24" Bass Drums | Maple(2)/Mahogany(6) 8-ply (7.2mm) | Fully Rounded | Booming bass tone with articulate punch |

Masters

The Masters You Remember,
A Sound You'll Never Forget

ELEVATING THE PLAYING EXPERIENCE FOR THE TRUE PROFESSIONAL.

Pearl's Masters Series has set a standard for the very best in performance centered instruments for the pro drummer. In celebration of three decades of Masters quality and excellence, Pearl reimagines three original shell recipes with a freshly unified hardware mix to reach new levels of sonic purity the most discerning environments and players.

MASTERS SHELL CHOICES



MASTERS MAPLE/GUM (MMG)

Masters Maple/Gum (MMG) Primed for the Recording Studio, this legendary shell blend enhances the naturally vibrant sonic nature of Maple with explosive highs and lows.



MASTERS MAPLE PURE (MP4)

The Original Masters Sound delivers full bodied resonant tone with increased lows and a more focused attack.

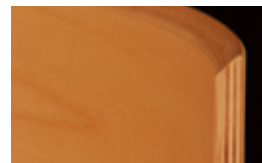

MASTERS MAPLE (MM6)

Originally offered as Masters MRX, projects powerfully expressive tone fit for evolving live music environments. Sonically centered with equal Highs/Mids/Lows.

MASTERS HARDWARE SELECTION

Adding the groundbreaking R2 Air Tom Suspension system's four point mounting platform to Pearl standards like premium North American shell veneers and Mastercast Die-Cast Hoops, Masters Series is the defining essence of the Pearl Sound and tailored to fit your sonic vision.



R2 AIR TOM MOUNTS

Suspends each drum by four unique points for optimum tone and resonance at any angle. (L-Arm bracket shown) U.S. Patent #11640814



PEARL STANDARD 7/8" PIPE OR 12.7mm L-ARM BRACKETS

A choice of Vertical or Horizontal Mounting and flexibility. (Standard bracket shown) U.S. Patent Pending



MASTERCAST HOOPS

The ultimate choice for durability and tuning integrity, they increase overall shell weight for enhanced tonal body and volume.



CL BRIDGE LUGS

A classic look with minimal shell contact for precise vibration control.



MASTERS MAPLE GUM KIT (MMGP924XSPL/C) IN #844 SATIN ROSE GOLD LACQUER FINISH
ON CONFIGURED ICON RACK SYSTEM WITH ADDED 8"x7" AND 13"x9" TOMS AND 14"x14" FLOOR TOM

Masters

MAPLE/GUM
HANDCRAFTED SHELL

The Evolution of
Premium Studio Tone



THE MASTERWORKS STUDIO RECIPE, SIMPLIFIED.

Delivering arguably the greatest drum tones ever recorded, Pearl's performance-centered take on the legendary Maple/Gum shell recipe is a sonic experience every drummer needs to witness. Reaching epic levels in sonic warmth and explosive low-end response, this dynamic shell/hardware combination first debuted as the Masterworks Sonic Select Studio Recipe. With the addition of the R2 Air Tom Suspension System, this is an instrument that is perfectly at home in the Recording environment, and a true prize for each drummer that owns one.



OUTER 60° BEARING EDGE
Gives increased power and bite to a thinner hybrid shell.



R2 AIR TOM SUSPENSION SYSTEM
Suspends each drum by four unique points for optimum tone and resonance at any angle. (U.S. Patent #11640814)



MASTERCAST HOOPS
The ultimate choice for durability and tuning integrity, they increase overall shell weight for enhanced tonal body and volume.



CL BRIDGE LUGS
A classic look with minimal shell contact for precise vibration control.



MMGC924XESPS/C + 14x14 Floor Tom
#857 Sunburst Redstripe



MMGC903XPL/C + 16x16 Floor Tom
#195 Crystal Rain

MASTERS SHELLS

Only the finest cuts of North American hardwood are harvested for Pearl's Masterworks Shell Vault. Cross laminated into dual-layered panels, each veneer in the Masters shell has been hand selected from this exclusive cache to produce drums worthy of Pearl's commitment to quality and performance.



SUPERIOR SHELL TECHNOLOGY

The SST method was developed to craft a multi-ply, bonded drumshell with single-ply resonance and strength. All shells are precision milled with overlapping scarf joint seams and cured with our exclusive AcoustiGlue at 1000 PSI of hydraulic pressure.

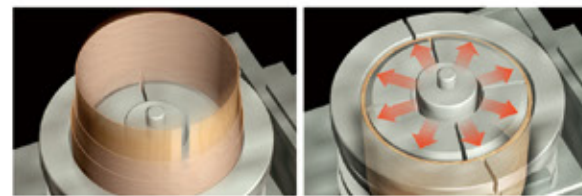

SHELLS

EvenPly-Six, 4-ply Maple outer with 2-ply Gumwood inside – The natural warmth of Maple is enhanced by Gumwood's dense, controlling character.



| | |
|---------------|--|
| SHELL | EvenPly-Six (6-ply, 5.4mm) North American Maple / Gumwood |
| SNARE | Matching 13x6.5, 14x5, 14x6.5, 14x8 |
| FINISH | CHOICE of 28 Hand-Applied Premium or Custom Lacquer Finishes |
| HEADS | Remo USA Coated Ambassador, Powerstroke3 Bass |
| TOM MOUNTS | R2 Air Tom Suspension System (U.S. Patent #11640814) |
| TOM ARMS | CHOICE of Pearl's Traditional 7/8" Pipe Holder or 12.7mm Solid L-Arm (Sold Separately) |
| DRUM HARDWARE | Chrome (Standard) Black nickel, Nickel and Black Chrome (Premium Charge) |
| HOOPS | Mastercast Hoops |
| LUGS | CL Bridge Lugs |
| BD MUFFLER | BDMF |

Masters

MAPLE
ALL MAPLE SHELL

Sonically Centered,
Articulate, and Powerful.



A BOLD VOICE FOR HIGH VOLUME STAGE PROJECTION.

With a sound that sits in the tonal center of the mix, Masters Maple is Pearl's original 6-ply shell recipe. This timeless combination of a slightly thicker 6-ply North American Maple shell and a sharper 45-degree bearing edge produces enough precise projection to shake the rafters, yet is responsive to even the slightest stroke. With an equalized high/mid/low tonality, Masters Maple is primed for cutting, vibrant live performance.



STANDARD 45° BEARING EDGE

Pearl's original precision edge adds sustain through reduced shell-to-head contact.



R2 AIR TOM SUSPENSION SYSTEM

Suspends each drum by four unique points for optimum tone and resonance at any angle. (U.S. Patent #11640814)



MASTERCAST HOOPS

The ultimate choice for durability and tuning integrity, they increase overall shell weight for enhanced tonal body and volume.



CL BRIDGE LUGS

A classic look with minimal shell contact for precise vibration control.



MM6C924XESPS/C + 14x14 Floor Tom
#198 Shimmer Of Oz

MM6P924XESPS/C + 14x14 Floor Tom
#103 Piano Black

MASTERS SHELL HARDWARE

Die-Cast for solid stability in the most demanding conditions, the appointments on each Masters shell were designed to draw the best tone from the shell they support. Mastercast Hoops, low mass CL Bridge Lugs, a choice of mounting options with the R2 Air Tom Suspension System, and refreshed adjustable Bass Drum Spurs and Floor Tom Brackets are standard.



USA REMO DRUM HEADS

All Pearl Masters come with REMO USA Drum Heads. Toms feature Coated Ambassador Batters with Clear Ambassador Resonant heads. Bass Drums are furnished with Powerstroke 3 Batter and Resonant heads, and come with our exclusive adjustable Dampening Pillow (BDMF).



SHELLS

6-ply, 7.5mm hand-selected North American Maple with Veneers from Pearl's Masterworks Vault.



| | |
|---------------|--|
| SHELL | 6-Ply, 7.5mm North American Maple |
| SNARE | Matching 13x6.5, 14x5, 14x6.5, 14x8 |
| FINISH | Choice of 28 Hand-Applied Premium or Custom Lacquer Finishes. |
| HEADS | Remo USA Coated Ambassador, Powerstroke3 Bass |
| TOM MOUNTS | R2 Air Tom Suspension System (U.S. Patent #11640814) |
| TOM ARMS | CHOICE of Pearl's Traditional 7/8" Pipe Holder or 12.7mm Solid L-Arm (Sold Separately) |
| DRUM HARDWARE | Chrome (Standard) Black nickel, Nickel and Black Chrome (Premium Charge) |
| HOOPS | Mastercast Hoops |
| LUGS | CL Bridge Lugs |
| BD MUFFLER | BDMF |

Masters

MAPLE PURE
ALL MAPLE SHELL

Bridging the Gap Between
Studio and Stage.



A POWERFUL TONAL BLEND OF RESONANCE AND ATTACK.

Pearl reimagines the original Masters shell recipe with Masters Maple Pure. Blending four layers of hand-curated North American Maple with 4-ply Re-Rings from our Masterworks Veneer Vault, its premium shell formula delivers a sonic fusion of near-field resonance and sharp top-end attack for varied pro environments. These hand-curated Maple plies increase the overall Janka hardness of the shell for increased projection, improved sustain, and better sonic output than ever before.



STANDARD 45° BEARING EDGE

Standard 45° – Pearl's original precision edge adds sustain through reduced shell-to-head contact.



R2 AIR TOM SUSPENSION SYSTEM

Suspends each drum by four unique points for optimum tone and resonance at any angle. (U.S. Patent #11640814)



MASTERCAST HOOPS

The ultimate choice for durability and tuning integrity, they increase overall shell weight for enhanced tonal body and volume.



CL BRIDGE LUGS

A classic look with minimal shell contact for precise vibration control.



MP4C924XESPL/C +
14x14 Floor Tom
#855 Black Oyster Swirl

MP4P924XSPL/C
#102 Natural Maple

MASTERS SELECTION

Pearl is committed to offering each drummer a top-tier experience in selecting and purchasing their Masters Series kit. Available for immediate delivery in a curated variety of in-stock components, Masters gives you the freedom of configuring your ideal set-up without the restriction of pre-formatted shell packs.



MASTERS FINISHES

Available in a wide range of Premium and Custom exterior lacquers, Masters drum finishes are hand-applied through Pearl's painstaking thirty-one step process. Choose from over 20 different Transparent, Metallic, Fade, Burst, Sparkle, Swirl, or Stripe Lacquers for your own unique statement.



SHELLS

5mm 4-ply shell w/4-ply Re-Rings blends hand-selected North American Maple Veneers from Pearl's Masterworks Vault.



| | |
|---------------|--|
| SHELL | 4-Ply, 5mm Maple w/4-ply Reinforcement Rings |
| SNARE | Matching 13x6.5, 14x5, 14x6.5, 14x8 |
| FINISH | CHOICE of 28 Hand-Applied Premium or Custom Lacquer Finishes. |
| HEADS | Remo Coated Ambassador, Powerstroke3 Bass |
| TOM MOUNTS | R2 Air Tom Suspension System (U.S. Patent #11640814) |
| TOM ARMS | CHOICE of Pearl's Traditional 7/8" Pipe Holder or 12.7mm Solid L-Arm (Sold Separately) |
| DRUM HARDWARE | Chrome (Standard) Black nickel, Nickel and Black Chrome (Premium Charge) |
| HOOPS | Mastercast Hoops |
| LUGS | CL Bridge Lugs |
| BD MUFFLER | BDMF |

PROFESSIONAL SERIES

ALL MAPLE SHELL

Est. 1986. An Updated,
Upgraded, Premium Gigging
Powerhouse.



A PLAYER-READY DRUM SET PLATFORM FIT FOR ACTIVE GIGGING AND TOURING..

From local gigs to national tours, Pearl's updated Professional Series drums have a look and sound that fits in any live performance space. Beginning in 1985, Pearl introduced its legendary MLX drums under the Professional Series banner to bring the powerful Maple sound to the forefront. Today, Professional Series returns with the spirit of the original and a refreshed presence for the experienced drummer.



STANDARD 45° BEARING EDGE

Standard 45° - Pearl's original precision edge adds sustain through reduced shell-to-head contact.



OPTIMOUNT SUSPENSION SYSTEM

A solid, flexible four point suspension mount for prime shell resonance.



2.3mm SuperHoop II

Made to maintain tuning integrity in heavy play while delivering maximum shell resonance.



RL LUGS

A simple, sleek lug that adds weight to the shell for increased volume.



PMX924BEDP/C
#448 White Marine Pearl

PMX943XP/C + 18x16 Floor Tom
#113 Sheer Blue

PERFORMANCE PROVEN

Made for lively sonic warmth from the cockpit, Professional Series drums broadcast with a broad frequency spectrum on and off the gig. A host of transparent Gloss Lacquer (and one Premium wrap) finishes assure a solid look and feel in varied venues and climates.



HARDWARE

Our classic RL Lug, OptiMount Tom Suspension System, 2.3mm Superhoop II, and Remo UT Pinstripe heads are added for strength and stability. Finally, to save your stand footprint and cartage load, Pearl's original UniLock independent bass drum mounted tom holders deliver maximum adjustability and positioning without robbing the shells of tone or sustain.



SHELLS

EvenPly-Six (5.4mm) North American Maple - Fuses reduced thickness, cross laminated ply panels for expanded tonal purity and increased resonance.



| | |
|---------------|---|
| SHELL | EvenPly-Six (5.4mm) North American Maple |
| SNARE | Matching 14 x 5, 14 x 6.5, 14 x 8 |
| FINISH | Premium Transparent Lacquer and USA Covered Finishes. |
| HEADS | Remo UT Pinstripe Batter Heads. |
| TOM MOUNTS | OptiMount Suspension System. |
| TOM ARMS | TH1030I x2 (with BB only) |
| DRUM HARDWARE | Chrome |
| HOOPS | 2.3mm Triple-Flanged SuperHoop II Hoops |
| LUGS | RL Lugs |
| BD MUFFLER | BDMM |

SESSION STUDIO SELECT

A Completely New Take
on the Full Spectrum Sound



A TRUE PEARL ORIGINAL, WITH A FRESH, GROOVE INSPIRING VIBE.

Taking a tip from the Masterworks spectrum, Session Studio Select's unparalleled combination of Masters-grade Birch and African Mahogany deliver a refined standout for recording and gigging.

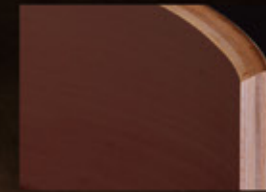

OUTER 60° BEARING EDGE
Increases volume and punch without harsh overtones.



OPTIMOUNT SUSPENSION SYSTEM
A solid, flexible four point suspension mount for prime shell resonance.



2.3mm SuperHoop II
Made to maintain tuning integrity in heavy play while delivering maximum shell resonance.



RL LUGS
A simple, sleek lug that adds weight to the shell for increased volume.



STS925XSP/C
#852 Black Satin Ash

STS925XSP/C
#314 Gloss Barnwood Brown

HARDWARE PARTS

Our classic RL Lug, OptiMount Tom Suspension System, 2.3mm Superhoop II hoops, and Remo UT Pinstripe heads are added for strength and stability.

| | |
|----------------------|---|
| SHELL | EvenPly-Six (6-ply, 5.4mm) Birch/African Mahogany |
| SNARE | 14 x 5.5, 14 x 6.5, or 14 x 8 Matching Wood |
| FINISH | Premium Wrapped or High Gloss Lacquer |
| HEADS | Remo Pinstripe Clear Tom, Powerstroke3 Bass, UT Coated Snare |
| TOM MOUNTS | OptiMount Suspension System |
| TOM ARMS | Sold Separately |
| DRUM HARDWARE | Chrome |
| HOOPS | 2.3mm Triple-Flanged SuperHoop II Hoops |
| LUGS | RL Lugs |
| BD MUFFLER | BDMM |

SHELLS

EvenPly-Six Birch/African Mahogany. An unique sonic dichotomy of piercing projection, smooth low-end and pre-EQ'd punch.



PRESIDENT

A Modern Revival of The Darkly Unique Luan Sound



DELIVERING A DISTINCTLY CLASSIC PLAYER'S GROOVE.

Drawing from the very origins of Pearl's manufacturing legacy, President Deluxe Series showcase the warm subtlety of our original tone wood for a traditionally full, controlled playing experience. Featuring our original 6-ply Luan shell, this darker toned medium/hardwood was the basis of thousands of shells made by Mitsuo Yanagisawa in Pearl's Chiba, Japan-based drum factory starting in 1961.



ROUNDED 45° BEARING EDGE
Increased head-to-shell contact boosts mids and highs and helps control overtone spread.



2.3mm SuperHoop II
Made to maintain tuning integrity in heavy play while delivering maximum shell resonance.



BSL LUGS
"The Battleship Lug", BSL100 features the same striking design of the original "C043" lug in a more robust casting for better tuning integrity.



SHELLS
6-ply 7.5mm Luan. Loud yet subdued with deep, punchy wallop and plenty of top-end attack.



PSD923XPC
#767 Ocean Ripple

PSD923XP/C
w/ added 14"x10", 12"x8", and 10"x7" Toms,
18"x16" and 14"x14" Floor Toms, and
PSD0810P/C Double Tom Set
#450 Silver Sparkle

A MODERN TAKE ON A FAMILIAR FAVORITE

President Series Deluxe drums feature prime vintage style without the shortcomings of yesterday's fittings. Available in three shell packs with a host of component add-ons, each President Series Deluxe drum kit comes standard with Remo CS "Black Dot" UT heads, classic felt bass drum muffling strip, shell-mounted cymbal holder, and adjustable "Gullwing" style bass drum spurs.



SINGLE-HEADED CONCERT TOM SET

A period-correct companion to President Series Deluxe shell packs. Includes 8"x6" and 10"x7" single headed toms with Traditional Slide/Clip mounts.



| | |
|-----------------|--|
| SHELL | 6-ply 7.5mm Luan |
| SNARE | 14" x 5.5" * Sold Separately |
| FINISH | Premium USA Wraps |
| HEADS | Remo UT CS Black Dot Batters Smooth White Coated Ambassador w/ Classic Pearl Logo |
| SPURS | BSP835 "Gullwing" Style |
| BD CYMBAL MOUNT | CHB75LB |
| HOOPS | 2.3mm Triple-Flanged SuperHoop II Hoops |
| LUGS | Battleship Lugs (BSL100 (Toms), BSL200 (Bass Drum)) |
| BD MUFFLER | BDMF and Resonant Felt Strip |

CRYSTAL BEAT

50 Years of the Original
Seamless Acrylic Drum Shell



THE ORIGINAL SEAMLESS ACRYLIC DRUM SET

Beginning in 1973, Pearl established a revolutionary alternative to conventional drum making with Crystal Beat's 6mm/7mm molded/seamless Acrylic shell. Its vivid combination of cutting tonal power and stunning visual appeal found an immediate audience with the high-volume power player. In celebration of this 50 year milestone, Pearl introduces three never before released acrylic finishes in a Limited Edition selection of Crystal Beat shell packs. Released quarterly throughout the year in Small Batch production runs, each shell pack is built to stand up to the rigors of touring with an undeniably unique look and straight-tone power.



STANDARD 45° BEARING EDGE

Pearl's original precision edge adds sustain through reduced shell-to-head contact.



OPTIMOUNT TOM SUSPENSION SYSTEM

A solid, flexible four point suspension mount for prime shell resonance.



1.6mm STEEL HOOPS

Solid tuning performance with reduced weight.



CRBL LUGS

Each sleek and efficient lug is individually isolated from shell contact with nylon gaskets to prevent hardware rattle in play.

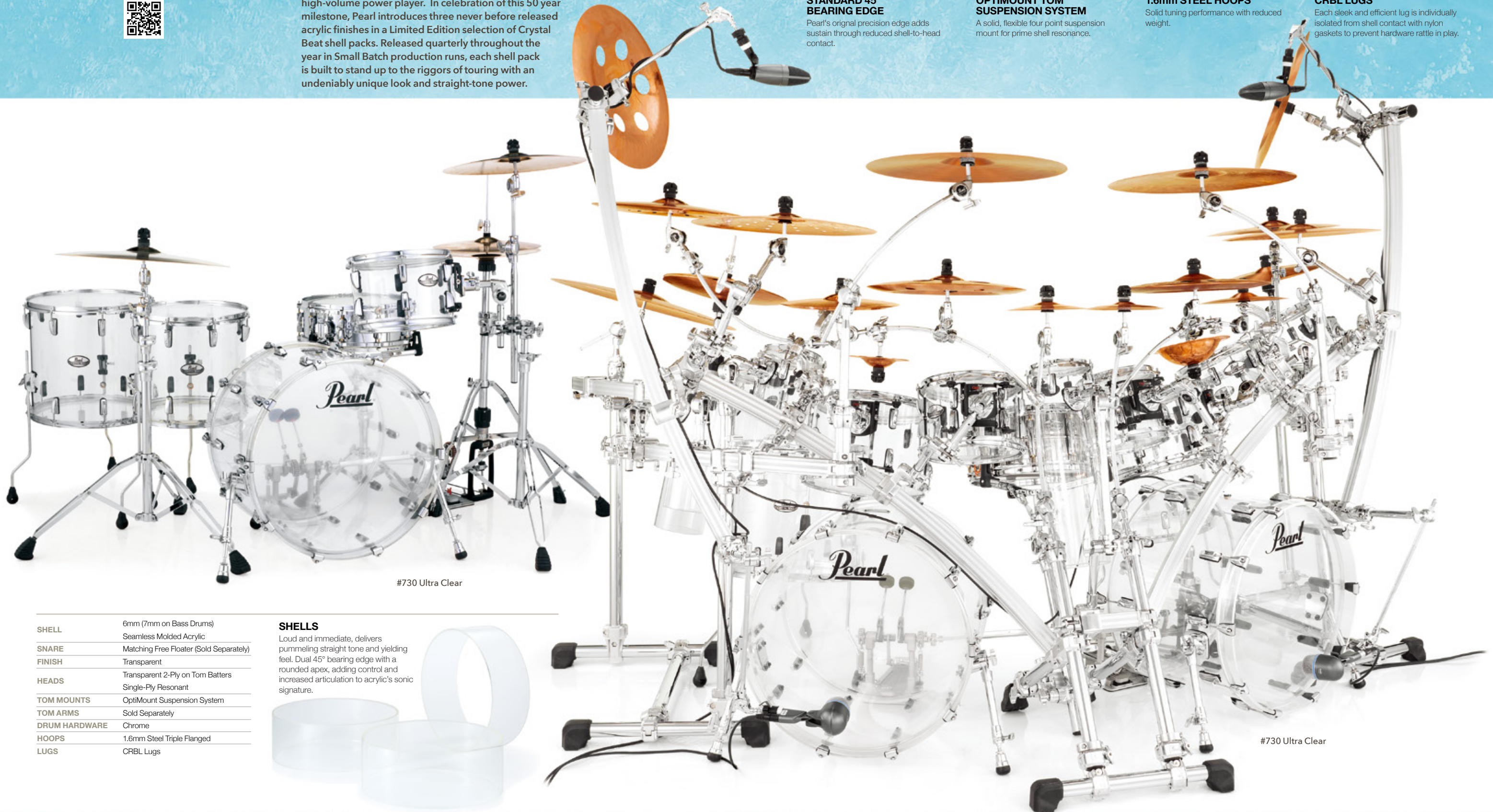

#730 Ultra Clear

#730 Ultra Clear

| | |
|---------------|---|
| SHELL | 6mm (7mm on Bass Drums) Seamless Molded Acrylic |
| SNARE | Matching Free Floater (Sold Separately) |
| FINISH | Transparent |
| HEADS | Transparent 2-Ply on Tom Batters Single-Ply Resonant |
| TOM MOUNTS | OptiMount Suspension System |
| TOM ARMS | Sold Separately |
| DRUM HARDWARE | Chrome |
| HOOPS | 1.6mm Steel Triple Flanged |
| LUGS | CRBL Lugs |

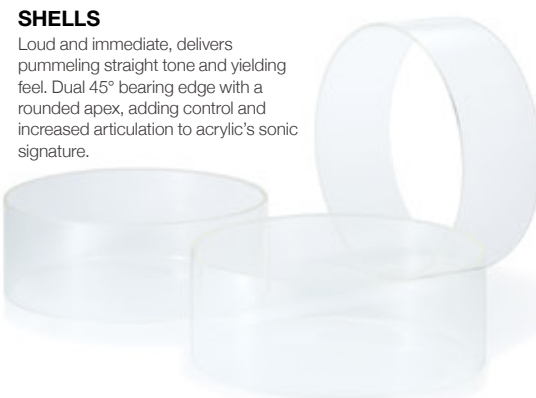

SHELLS

Loud and immediate, delivers pummeling straight tone and yielding feel. Dual 45° bearing edge with a rounded apex, adding control and increased articulation to acrylic's sonic signature.

DECADE MAPLE

A Drum Kit
10 Years in the Making



BUILT TO PUSH THE BOUNDARIES OF PERFORMANCE AND PRICE

Decade Maple Series drums elevate the playing field for the advancing drummer with pro features and unbeatable value. Over seven decades of Pearl drum craftsmanship and ten full years of research and development culminate in the ideal step up drum kit: Decade Maple Series. Escalating the playing field for the advancing drummer, Decade Maple's featured shell packs are perfect as a primary kit for evolving players or a secondary "gigging" kit for the seasoned pro.



STANDARD 45° BEARING EDGE

Pearl's original precision edge adds sustain through reduced shell-to-head contact.



OPTI-LOC MOUNTING SYSTEM

This three-point isolation mount suspends the drum at two tuning points and one of the drum's air vents for solid, stable play.



1.6mm STEEL HOOPS

Solid tuning performance with reduced weight.



NDL LUGS

Small, efficient, and strong, the NDL lug is designed to hold tuning across all points without taking up too much room on the shell.



DMP943XP/C
#849 Rose Mirage

DMP925SP/C
#208 Blue Mirage

BDMM BASS DRUM MUFFLER

Brings out the PUNCH in your kick.



HARDWARE

- Uni-Lock gearless Tom Arms.
- R40 Air Suspension Floor Tom feet.
- ND Lugs: For reliable, rock solid durability and sound.



SHELLS

EvenPly-Six / 5.4mm Maple - Thin (but powerfully strong) Pearl's SST shell reacts quickly to the stroke with beautifully resonant highs and thundering lows.



| | |
|---------------|---|
| SHELL | EvenPly-Six (5.4mm) 100% Maple |
| SNARE | Matching 14 x 5.5 |
| FINISH | High-Gloss / Matte Lacquer |
| HEADS | Remo UT Clear Ambassador Tom, Ported UT Powerstroke3 Bass |
| TOM MOUNTS | Opti-Loc Mounting System |
| DRUM HARDWARE | Chrome |
| HOOPS | 1.6mm Steel Hoops |
| LUGS | NDL Lugs |
| BD MUFFLER | BDMM (Mini) |



The Legends of Tomorrow,
Play Export Today



THE BEST SELLING DRUM SET OF ALL TIME.

THE BEST SELLING DRUM SET OF ALL TIME

The Export Series 30 year pedigree of unbeatable quality and value shines on with Reference-inspired shell woods and high impact hardware, giving the rising player a truly high end playing platform.

Export Series drums are available in three preconfigured packages with our robust 830 Series hardware; and feature a choice of durable wrapped (EXX) finishes. Pearl carries this tradition forward with our best Export ever - fully loaded with all the features to advance your playing voice to new heights. Never settle. Play Export.



STANDARD 45° BEARING EDGE

Pearl's original precision edge adds sustain through reduced shell-to-head contact.



OPTI-LOC MOUNTING SYSTEM

This three-point isolation mount suspends the drum at two tuning points and one of the drum's air vents for solid, stable play.



1.6mm STEEL HOOPS

Solid tuning performance with reduced weight.



NEL LUGS

Small and elegant for reduced real estate on the shell, but efficient enough for tuning integrity in play.



EXX705N/C
#21 Smokey Chrome



EXX7255/C, EXX22 Add-On Pack.
#31 Jet Black

| | |
|---------------|--|
| SHELL | 6-Ply 7.5mm Poplar & Asian Mahogany Blend |
| SNARE | 14 x 5.5 Matching Wood Snare |
| FINISH | Choice of 5 Covered Finishes |
| HEADS | Remo Clear Tom Head, Powerstroke Bass Head |
| TOM MOUNTS | Opti-Loc Mounting System |
| TOM ARMS | TH701 |
| DRUM HARDWARE | Chrome |
| HARDWARE | P930, BC830, C830, H830, S830 |
| BD MUFLER | BDMM (Mini) |



830 SERIES HARDWARE

Sophisticated, sturdy, and efficient, Export's 830 Series Boom (BC830), Cymbal (C830), and Snare (S830) stands all feature gearless Uni-Lock Tilters for pinpoint positioning, and robust double-braced tripods for stability and security.

P930 PEDAL

Featuring the longboard styling and feel of Pearl's Demon Drive pedal, the P930 offers two chain drive cam options for power, speed, and control. The matching H830 Hi-Hat stand also features swivel legs that accommodate double pedals.



SHELLS

6-Ply 7.5mm Poplar & Asian Mahogany Blend (but powerfully strong) Pearl's SST shell reacts quickly to the stroke with beautifully resonant highs and thundering lows.

MIDTOWN

BIG GIG, SMALL RIG, HUGE SOUND



MDT764P/C
#701 Black Gold Sparkle

SHELLS

6-Ply (7.5 mm) Poplar.
Quick and biting attack
with lively overtones.



FINISHES



#33 Pure White

#701 Black Gold Sparkle

#704 Black Cherry Glitter

HARDWARE

Lift used on Midtown
raises the drum to
the optimal position
for your pedal.



CONFIGURATIONS

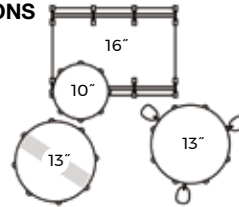

INSTANTLY PORTABLE

The Midtown Kit's compact size
quickly breaks down into two
optional gig bags (PMTBG) for
quick transport.

SETTING THE PULSE FOR THE METROPOLITAN GROOVE

Pearl's ultra portable Midtown Kit is the
perfect sounding board for full size sound
and play in a smaller footprint. Ideal for tight
gigging spaces on a budget.

| | |
|----------|--|
| SHELL | 6-Ply (7.5 mm) Poplar |
| SNARE | Matching 13x5.5 Wood Snare Drum |
| FINISH | Choice of 3 Covered Finishes |
| HEADS | Remo UC Clear Tom Remo UC Clear Powerstroke Batter Bass Remo UC Coated Snare |
| TOM ARMS | TH701 |
| HARDWARE | Chrome |

ROADSHOW

IT'S YOUR TIME TO PLAY,
START THE RIGHT WAY!

THE RHYTHM IS IN YOU

Drumming knows no age limit. Regardless
of when your rhythmic journey starts, Pearl's
Roadshow Series has a drum set package
scaled for players of all ages that includes
everything you need to get on the road to
drumming greatness.



RS525SC/C
#749 Burnt Orange Sparkle

| | |
|-------------|---|
| SHELL | 9-Ply 7mm Asian White Poplar |
| SNARE | Matching Wood Snare |
| FINISH | Choice of 5 Covered Finishes |
| HEADS | Clear Tom Heads, Coated Snare Head, Self-Muffled Bass Head |
| TOM ARMS | Individually Locking 7/8" Tube Joint Holders |
| HARDWARE | Dual-Chain Drive Bass Drum Pedal Double-Braced Cymbal*, Snare and Hi-Hat Stands, Double-Braced Throne |
| CYMBALS | 16" Brass Cymbal, 14" Brass/ Hybrid Hi-Hat Cymbals |
| ACCESSORIES | Pro Drum Stick Bag, Two pairs of Maple 5A Sticks |

*Docking Cymbal Boom Arm Included with RS584C/C

CONFIGURATIONS

Complete Sets with Hardware,
Cymbals, and Throne.
Includes CH50/H50/S50*/P50/D50/
16" Crash/14" Hi-Hats, Stick Bag, Sticks

RS584C/C

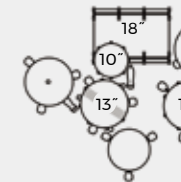

RS505C/C

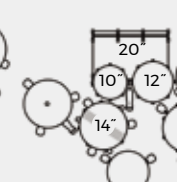

RS525SC/C

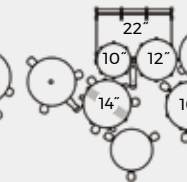

RS525WFC/C

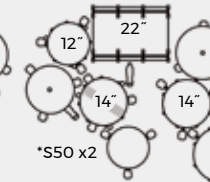

RS584C/C
#706 Charcoal Metallic

THE HEART OF THE ROADSHOW SOUND.

Roadshow is crafted to be everything you'd expect from a Pearl Drum set, featuring a 9-ply Poplar
shell for optimum tonal power.



#91 Red Wine

#703 Aqua Blue Glitter

#706 Charcoal Metallic

#707 Bronze Metallic

#749 Burnt Orange Sparkle

ROCKET TOMS

For striking staccato tone that's both melodic and
piercing, Pearl's Rocket Toms are 6" pitched toms in
varying lengths made to expand the sonic palette of
any drum kit.

Available in sets or as individual components in
Aluminum. Finishes: #103 Piano Black, #109 Arctic
White, or #730 Ultra Clear Acrylic.



| | |
|-----------|-------------------------------------|
| AL0612/C | 6" x 12" |
| AL0615/C | 6" x 15" |
| AL0618/C | 6" x 18" |
| AL0621/C | 6" x 21" |
| ALX1215/C | 6" x 12", 6" x 15" (w/ T890) |
| ALX1821/C | 6" x 18", 6" x 21" (w/ T890) |
| CRB612/C | 6" x 12" (Acrylic #730 Ultra Clear) |
| CRB615/C | 6" x 15" (Acrylic #730 Ultra Clear) |
| CRB618/C | 6" x 18" (Acrylic #730 Ultra Clear) |
| CRB621/C | 6" x 21" (Acrylic #730 Ultra Clear) |

COMPACT TRAVELER

| | |
|---------------|--|
| BASS DRUM | 18" w/ Base Frame & L-Arm Handle |
| SNARE | 10" w/ Adjustable Snare Rake |
| STANDS | Sold Separately |
| CARRYING CASE | PSCPCTK (Sold Separately) |
| ADD ON PACK | PCTK1014 Includes 10" & 14" Toms w/ Mounting Hardware |

Take the rhythm on the road with Pearl's
totally portable, super playable, ultra
affordable beat maker. Perfect for
School, Street, Practice, and Stage.



Shown with PCTKT1014
add on pack*
PCTK1810



Pedal sold separately
PCTK1810

Add on pack (10" & 14" toms
w/ mounting hardware)
PCTKT1014

Optional
Compact
Traveler Bag
PSCPCTK

Optional
Compact Traveler
Add on Bag
PSCPCTKADD

ROADSHOW JR.

Pearl's Roadshow Jr. is NOT a toy. It's a serious, all-in-one,
five piece drum set sized for kids under 8-years-old featuring
hardware, cymbals, and sturdy White Poplar shell construction
for an exceptionally powerful drumming start.

Complete with
Hardware,
Cymbals, and
Throne for
Drummers under 8.

RSJ465/C

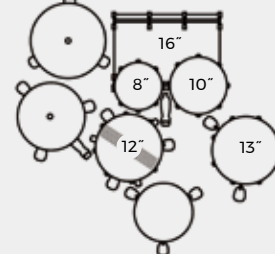

For additional info,
testimonials, free assembly
and instructional videos, and
access to the largest drummer's
community on the web, go to:



#31 Jet Black

#708 Grindstone
Sparkle

MUSIC CITY CUSTOM

Solid Shell Snare Drums Handcrafted in the USA



DISCOVER THE SNARE DRUM YOU'VE BEEN WAITING FOR.

A singular tonal expression that elevates your approach to playing - and feeling - the drums.

Pearl's Music City Custom Solid Shell Snare Drums are uniquely refined, American made percussion instruments crafted with time honored precision. Using an old world technique derived from the shipbuilding trade, each solid shell is meticulously hand-formed from a steam treated plank of premium North American lumber.

Each Music City Custom Solid Shell Snare is then drilled with CNC precision before being hand finished and assembled by our Custom Shop team in Nashville, TN.

The natural beauty of each shell is further refined with a hand-rubbed oil finish available in a choice of standard Nashville Natural or with one of our exceptional, exotic inlay options. Pearl's Music City Custom Solid Shell Snare Drums are truly instruments elevated above all others.



Our handcrafted Solid Shell Snare Drums all feature Solid Maple Reinforcement Rings bonded to both top and bottom of the shell interior.

SOLID SHELL WOOD OPTIONS



SOLID MAPLE

The standard for premium, tonally centered midrange punch and restrained overtone.



SOLID CHERRY

Slightly brighter in tone than Maple with cutting projection. Best suited for a higher velocity stroke.



SOLID WALNUT

A fat growl with a naturally darker tone, the sound of Walnut is a perfect complement to its luxurious grain.



SOLID ASH

Brighter, louder, and with the crack of a homerun hit, the tonal quality of Ash is punchy with extended sustain.

MUSIC CITY CUSTOM

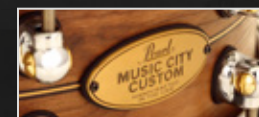

| | |
|----------|---------------------------------|
| SHELL | 8mm w/ 6mm Solid Maple Re-Rings |
| EDGE | Standard 45° |
| HOOPS | SuperHoop II |
| LUGS | STL100 |
| RODS | Stainless Steel |
| STRAINER | SR017 |
| SNARES | SN1420I (U.S. Patent #7202405) |

FINISH AND INLAY OPTIONS

Craft an instrument that truly demands your attention. Each Solid Shell Wood Option is available in your choice of hand rubbed Nashville Natural (without inlay) or configured with one of these exotic inlay options:

#1002
KINGWOOD ROYAL INLAY
(Shown on 14" x 6.5" Maple)
Centered Nicotine White Marine Pearl band surrounded by dual Kingwood inlay strips.
• Available only on 6.5" models



#1003
DUOBAND EBONY MARINE INLAY
(Shown on 14" x 6.5" Ash)
A White Nicotine Marine Pearl band surrounded by dual inlay strips of Macassar Ebony.
• Available only on 6.5" models



#1004
BOXWOOD-ROSE TRIBAND INLAY
(Shown on 14" x 6.5" Cherry)
Three thin bands of Artisan Rosewood and Boxwood creates a stunning inlay.
• Available only on 6.5" models



#1001
KINGWOOD CENTER INLAY
(Shown on 14" x 5" Maple)
A dark, dense inlay from the exotic Brazilian Rosewood family with a rich vertical grain.
• Available on all 5" & 6.5" models



#1005
NICOTINE WHITE MARINE INLAY
(Shown on 14" x 5" Maple)
Embeds a single 6mm band of White Nicotine Marine Pearl in the shell center.
• Available only on 5" models



#1006
BOXWOOD-ROSE SINGLE INLAY
(Shown on 14" x 5" Walnut)
A single strip of combined Artisan Rosewood and Boxwood for an elegant inlay.
• Available only on 5" models



#1007
EBONY SINGLE INLAY
(Shown on 14" x 5" Maple)
A solitary center inlay of imported Macassar Ebony.
• Available only on 5" models



SERIES COMPONENT

Reference One, Masters MMG Series

Masters Maple, Masters Maple Pure, Professional Series

Reference One

A nuanced, refined balance of sensitive response and sonic versatility, Reference One Series Snare Drums are an exceptional complement to the total sound of any drum set. Combining an EvenPly blend of hand-curved North American Maple and Birch, the 5.4mm Reference One shell delivers a smooth, resonant quality with heightened top-end pop at the hit. Each snare's hardware selection includes elements that balance overall weight from top to bottom, for supreme sensitivity and crisp projection.



Quick, yielding snap with heavy midrange tonality.
RF1P1450S/C



A sonic dichotomy of versatile crack and guttural punch.
RF1P1465S/C



Low, thunderous wallop with yielding power in play.
RF1P1480S/C

| | |
|--------------------|---|
| RF1P1450S/C | 14" x 5" |
| SHELL | EvenPly-Six (5.4mm) Maple 4 + Birch 2 |
| HOOPS | MasterCast (DC1410 / DC1410S) |
| LUGS | STL100 |
| RODS | SST5047 (20) |
| STRAINER | SR1000 |
| SNARES | SN14201 (Using Cord) (U.S. Patent #7202405) |
| HEADS | REMO Coated (A) |

| | |
|--------------------|---|
| RF1P1465S/C | 14" x 6.5" |
| SHELL | EvenPly-Six (5.4mm) Maple 4 + Birch 2 |
| HOOPS | MasterCast (DC1410 / DC1410S) |
| LUGS | STL100 |
| RODS | SST5047 (20) |
| STRAINER | SR1000 |
| SNARES | SN14201 (Using Cord) (U.S. Patent #7202405) |
| HEADS | REMO Coated (A) |

| | |
|--------------------|---|
| RF1P1480S/C | 14" x 8" |
| SHELL | EvenPly-Six (5.4mm) Maple 4 + Birch 2 |
| HOOPS | MasterCast (DC1410 / DC1410S) |
| LUGS | STL100 (U.S. Patent 7220905) |
| RODS | SST5047 (20) |
| STRAINER | SR1000 |
| SNARES | SN14201 (Using Cord) (U.S. Patent #7202405) |
| HEADS | REMO Coated (A) |

Masters Maple, Masters Maple Pure

With shell recipes from each of the three branches of the Masters Series line-up, Masters Snare Drums' individually versatile nature is prime for the forward-focused drummer. Their collective rhythmic voice sings with the unity of a family of Maple instruments, but with enough tonal variety from model to model to make them totally unique. Available in four sizes and a kaliedescope of dazzling finishes, Masters Snares deliver the excellence you have come to expect from the world's leading drum maker.



Full-Spectrum snare power with thick bottom-end focus.
MM6P1465S/C



Responsive low-range focus with high impact drive.
MP4P1450S/C

| | |
|--------------------|--------------------------------|
| MM6P1465S/C | 14" x 6.5" |
| SHELL | 6 ply (7.5mm) Maple |
| HOOPS | MasterCast (DC1410 / 1410S) |
| LUGS | CL65 |
| RODS | SST5047 (20) |
| STRAINER | SR17A / SR150E |
| SNARES | SN14201 (U.S. Patent #7202405) |
| HEADS | REMO Coated (A) |

| | |
|--------------------|------------------------------------|
| MP4P1450S/C | 14" x 5" |
| SHELL | 4 ply Maple w/4 ply Maple Re-Rings |
| HOOPS | MasterCast (DC1410 / 1410S) |
| LUGS | CL55 |
| RODS | SST5047 (20) |
| STRAINER | SR17A / SR150E |
| SNARES | SN14201 (U.S. Patent #7202405) |
| HEADS | REMO Coated (A) |

MMG, MM6, & MP4 Snare Drums are Available in 13 x 6.5, 14 x 5, 14 x 6.5, and 14 x 8.

Professional Series

Professional Series Snare Drums are an exceptional avenue for the gigging pro. Their EvenPly shell fuses six reduced thickness layers of cross-laminated North American Maple for expanded tonal purity, increased resonance, and dramatically different snare sensitivity.



Tried-and-true Maple tone fit for the concert stage.
PMX1450S/C



Deep pocket, low sustain punch without overpowering.
PMX1465S/C

| | |
|-------------------|-------------------------------|
| PMX1450S/C | 14" x 5" |
| SHELL | EvenPly-Six (5.4 mm) Maple |
| HOOPS | SuperHoop II (SH1410 / 1410S) |
| LUGS | CL55 |
| RODS | T062 (20) |
| STRAINER | SR017 |
| SNARES | S022N |
| HEADS | REMO UT Coated (A) |

| | |
|-------------------|-------------------------------|
| PMX1465S/C | 14" x 6.5" |
| SHELL | EvenPly-Six (5.4 mm) Maple |
| HOOPS | SuperHoop II (SH1410 / 1410S) |
| LUGS | CL65 |
| RODS | T061L (20) |
| STRAINER | SR017 |
| SNARES | S022N |
| HEADS | REMO UT Coated (A) |

Masters Maple Gum

With shell recipes from each of the three branches of the Masters Series line-up, Masters Snare Drums' individually versatile nature is prime for the forward-focused drummer. Their collective rhythmic voice sings with the unity of a family of Maple instruments, but with enough tonal variety from model to model to make them totally unique. Available in four sizes and a kaliedescope of dazzling finishes, Masters Snares deliver the excellence you have come to expect from the world's leading drum maker.



Solid, high-centered tonal punch with full range body.
MMGC1465S/C



Exceptionally well-rounded sound for any groove.
MMGP1450S/C

| | |
|--------------------|---|
| MMGC1465S/C | 14" x 6.5" |
| SHELL | EvenPly-Six (5.4mm) Maple 4 + Gumwood 2 |
| HOOPS | MasterCast (DC1410 / 1410S) |
| LUGS | CL65 |
| RODS | SST5047 (20) |
| STRAINER | SR17A / SR150E |
| SNARES | SN14201 (U.S. Patent #7202405) |
| HEADS | REMO Coated (A) |

| | |
|--------------------|---|
| MMGP1450S/C | 14" x 5" |
| SHELL | EvenPly-Six (5.4mm) Maple 4 + Gumwood 2 |
| HOOPS | MasterCast (DC1410 / 1410S) |
| LUGS | CL55 |
| RODS | SST5047 (20) |
| STRAINER | SR17A / SR150E |
| SNARES | SN14201 (U.S. Patent #7202405) |
| HEADS | REMO Coated (A) |



Wide tuning range from thuddy to cracking volume.
PMX1480S/C

| | |
|-------------------|-------------------------------|
| PMX1480S/C | 14" x 8" |
| SHELL | EvenPly-Six (5.4 mm) Maple |
| HOOPS | SuperHoop II (SH1410 / 1410S) |
| LUGS | CL100 |
| RODS | T061L (20) |
| STRAINER | SR017 |
| SNARES | S022N |
| HEADS | REMO UT Coated (A) |

SERIES COMPONENT

Session, Decade, & President Classic Pearl Sound



DRUM SET SERIES SNARE DRUMS Made to match the sound and feel of your Pearl drum set.



STS1480S/C



STS1465S/C



STS1455S/C



DMP1455/C



PSD1455SE/C



PSD1455SE/C

STS1480S/C 14" x 8"

| | |
|----------|--|
| SHELL | EvenPly-Six (5.4mm) Birch / African Mahogany |
| HOOPS | SuperHoop II (SH1410 / 1410S) |
| LUGS | CL100 |
| RODS | T061L (20) |
| STRAINER | SR017 |
| SNARES | S022N |
| HEADS | REMO UT Coated (A) |

STS1465S/C 14" x 6.5"

| | |
|----------|--|
| SHELL | EvenPly-Six (5.4mm) Birch / African Mahogany |
| HOOPS | SuperHoop II (SH1410 / 1410S) |
| LUGS | CL65 |
| RODS | T061L (20) |
| STRAINER | SR017 |
| SNARES | S022N |
| HEADS | REMO UT Coated (A) |

STS1455S/C 14" x 5.5"

| | |
|----------|--|
| SHELL | EvenPly-Six (5.4mm) Birch / African Mahogany |
| HOOPS | SuperHoop II (SH1410 / 1410S) |
| LUGS | CL55 |
| RODS | T062 (20) |
| STRAINER | SR017 |
| SNARES | S022N |
| HEADS | REMO UT Coated (A) |

DMP1455S/C 14" x 5.5"

| | |
|----------|------------------------------|
| SHELL | EvenPly-Six (5.4 mm) Maple |
| HOOPS | 1.6mm Steel (RH1408 / 1408S) |
| LUGS | NDL55/C |
| RODS | TR5052 (16) |
| STRAINER | SR700 |
| SNARES | SNW1420 |
| HEADS | REMO UT Coated (A) |

PSD1455SE/C 14" x 5.5"

| | |
|----------------|--------------------------------|
| SHELL | 6 ply (7.5mm) Lauan |
| HOOPS | SuperHoop II (SH1408 / 1408S) |
| LUGS | BSL55 |
| RODS | T062 (16) |
| STRAINER | SR-17A / SR-150E |
| SNARES | SN1420I (U.S. Patent #7202405) |
| HEADS | REMO CS |
| FINISH *option | #450 Silver Sparkle |
| INSIDE MUFFLER | IM100W |

PSD1455SE/C 14" x 5.5"

| | |
|----------------|--------------------------------|
| SHELL | 6 ply (7.5mm) Lauan |
| HOOPS | SuperHoop II (SH1408 / 1408S) |
| LUGS | BSL55 |
| RODS | T062 (16) |
| STRAINER | SR-17A / SR-150E |
| SNARES | SN1420I (U.S. Patent #7202405) |
| HEADS | REMO CS |
| FINISH *option | #767 Ocean Ripple |
| INSIDE MUFFLER | IM100W |

FREE FLOATING

The Ultimate Purity Of Sound

TASK-SPECIFIC INNOVATION Pearl's unique Free Floating Snare chassis removes all hardware from the shell to greatly improve resonance and projection.

By combining the tonal character of each shell type with its ideally matched depth, each Free Floating snare drum is engineered to fit a specific task by model and gives you a unique voice for any sonic situation.

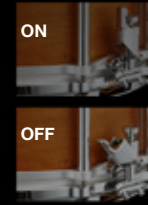

CLICK-LOCK THROW-OFF SYSTEM Engineered with Polymer bearings for precise and smooth action. Unique nylon grip mechanism locks the snares into place.



Deep, rich snare power with short, even sustain decay.
FTAL1480



Ultimate in throaty, deep snare growl. Shortened decay.
FTMH1480



Lower overtone body, preserves crisp top-end snare snap.
FTPB1465



Full, rounded bottom frequencies. Extra midrange body.
FTMMH1465



Full-spectrum, both bright in punch and warm in tone.
FTBR1450



Punchy and smooth. A perfect "go-to" snare.
FTMM1450



1mm shell for bright, open attack with ringy overtone.
FTSS1435



Dense all Birch shell delivers bright, open attack.
FTBB1435

FTAL1480 14" x 8"

| | |
|----------|--------------------------------|
| SHELL | 1.2mm Seamless Aluminum |
| HOOPS | MasterCast (DC1410 / DC1410S) |
| LUGS | FT80 |
| RODS | SST5042 (20) |
| STRAINER | SR160F (U.S. Patent 9082376) |
| SNARES | SN1442C (U.S. Patent #7202405) |
| HEADS | REMO Coated (A) |

FTMH1480 14" x 8"

| | |
|----------|--------------------------------|
| SHELL | 8 ply (10mm) African Mahogany |
| HOOPS | MasterCast (DC1410 / DC1410S) |
| LUGS | FT80 |
| RODS | SST5042 (20) |
| STRAINER | SR160F (U.S. Patent 9082376) |
| SNARES | SN1442C (U.S. Patent #7202405) |
| HEADS | REMO Coated (A) |

FTPB1465 14" x 6.5"

| | |
|----------|--------------------------------|
| SHELL | 1.2mm Phosphor Bronze |
| HOOPS | MasterCast (DC1410 / DC1410S) |
| LUGS | FT65 |
| RODS | SST5042 (20) |
| STRAINER | SR160F (U.S. Patent 9082376) |
| SNARES | SN1420C (U.S. Patent #7202405) |
| HEADS | REMO Coated (A) |

FTMMH1465 14" x 6.5"

| | |
|----------|--|
| SHELL | 6 ply (7.5mm) (4 ply Maple w/2 ply Inner African Mahogany) |
| HOOPS | MasterCast (DC1410 / DC1410S) |
| LUGS | FT65 |
| RODS | SST5042 (20) |
| STRAINER | SR160F (U.S. Patent 9082376) |
| SNARES | SN1420C (U.S. Patent #7202405) |
| HEADS | REMO Coated (A) |

FTBR1450 14" x 5"

| | |
|----------|--------------------------------|
| SHELL | 1mm Brass |
| HOOPS | MasterCast (DC1410 / DC1410S) |
| LUGS | FT50 |
| RODS | SST5042 (20) |
| STRAINER | SR160F (U.S. Patent 9082376) |
| SNARES | SN1420I (U.S. Patent #7202405) |
| HEADS | REMO Coated (A) |

FTMM1450 14" x 5"

| | |
|----------|--------------------------------|
| SHELL | 6 ply (7.5mm) Maple |
| HOOPS | MasterCast (DC1410 / DC1410S) |
| LUGS | FT50 |
| RODS | SST5042 (20) |
| STRAINER | SR160F (U.S. Patent 9082376) |
| SNARES | SN1420I (U.S. Patent #7202405) |
| HEADS | REMO Coated (A) |

FTSS1435 14" x 3.5"

| | |
|----------|--------------------------------|
| SHELL | 1mm Stainless Steel |
| HOOPS | MasterCast (DC1410 / DC1410S) |
| LUGS | FT35 |
| RODS | SST5035 (20) |
| STRAINER | SR160F (U.S. Patent 9082376) |
| SNARES | SN1420D (U.S. Patent #7202405) |
| HEADS | REMO Coated (A) |

FTBB1435 14" x 3.5"

| | |
|----------|--------------------------------|
| SHELL | 6 ply (5.4mm) Birch |
| HOOPS | MasterCast (DC1410 / DC1410S) |
| LUGS | FT35 |
| RODS | SST5035 (20) |
| STRAINER | SR160F (U.S. Patent 9082376) |
| SNARES | SN1420D (U.S. Patent #7202405) |
| HEADS | REMO Coated (A) |

SENSITONE HERITAGE ALLOY

Legendary Snare Tone from Studio to Stage

The Sensitone sound has always been drawn from an amalgamation of The Heritage Alloys (Aluminum, Black-over-Brass, and Steel) for the necessary, immediate tones of yesterday's chart toppers with an undeniably modern sensibility. Sensitone Heritage Alloy snare models employ these three original metal shell types to deliver essential tone and power with the right gig-ready touches.



Dry, focused crack with quick decay.
STH1450AL



Full, guttural snare bellow with little overtone.
STH1465AL



Perfect blend of attack and brassy body.
STH1450BR



An elegant solution for punch and warmth.
STH1465BR



Crisp, sensitive high-pitched snap.
STH1450S



Belting crack with mild midrange overtone.
STH1465S

| | |
|------------------|--------------------------------|
| STH1450AL | 14" x 5" |
| SHELL | 1.2mm Beaded Aluminum |
| HOOPS | SuperHoop II (SH1410B / 1410S) |
| LUGS | CL55 |
| RODS | T061L (20) |
| STRAINER | SR017 |
| SNARES | SN1420I (U.S. Patent #7202405) |
| HEADS | REMO Coated (A) |

| | |
|------------------|--------------------------------|
| STH1465AL | 14" x 6.5" |
| SHELL | 1.2mm Beaded Aluminum |
| HOOPS | SuperHoop II (SH1410B / 1410S) |
| LUGS | CL65 |
| RODS | T061L (20) |
| STRAINER | SR017 |
| SNARES | SN1420I (U.S. Patent #7202405) |
| HEADS | REMO Coated (A) |

| | |
|------------------|--------------------------------|
| STH1450BR | 14" x 5" |
| SHELL | 1mm Beaded Black Nickel/Brass |
| HOOPS | SuperHoop II (SH1410B / 1410S) |
| LUGS | CL55 |
| RODS | T061L (20) |
| STRAINER | SR017 |
| SNARES | SN1420I (U.S. Patent #7202405) |
| HEADS | REMO Coated (A) |

| | |
|------------------|--------------------------------|
| STH1465BR | 14" x 6.5" |
| SHELL | 1mm Beaded Black Nickel/Brass |
| HOOPS | SuperHoop II (SH1410B / 1410S) |
| LUGS | CL65 |
| RODS | T061L (20) |
| STRAINER | SR017 |
| SNARES | SN1420I (U.S. Patent #7202405) |
| HEADS | REMO Coated (A) |

| | |
|-----------------|--------------------------------|
| STH1450S | 14" x 5" |
| SHELL | 1mm Beaded Steel |
| HOOPS | SuperHoop II (SH1410B / 1410S) |
| LUGS | CL55 |
| RODS | T061L (20) |
| STRAINER | SR017 |
| SNARES | SN1420I |
| HEADS | REMO Coated (A) |

| | |
|-----------------|--------------------------------|
| STH1465S | 14" x 6.5" |
| SHELL | 1mm Beaded Steel |
| HOOPS | SuperHoop II (SH1410B / 1410S) |
| LUGS | CL65 |
| RODS | T061L (20) |
| STRAINER | SR017 |
| SNARES | SN1420I |
| HEADS | REMO Coated (A) |

THE SR017 STRAINER

Simple and effective, the SR017 is a Pearl standard for effortless snare switching and sensitivity control. Its smooth lever action and fine-tuning knob let you dial in the right amount of snare wire saturation to suit your personal sound.

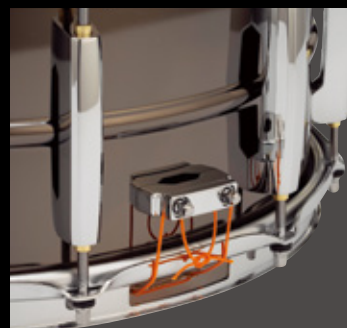

ON

OFF

SIGNATURE SNARES

Capturing The Exclusive Sound of Drumming Legends

To be truly great, one must evolve over time. Drumming legend Dennis Chambers took this to heart when considering the transformation of his snare drum sound.

Dennis designed his new Signature Snare for sonic evolution. Using the multi-lug design of his previous model, it employs 10 tuning points on the batter head and eight on the bottom for top-end tonal focus.

Returning to the 4-ply Maple w/ 4-ply Re-Ring shell of his original Signature model, this time in a Matte Black lacquer finish for visual versatility, it features a solid, searing and articulate sound that fits well in any playing field.

The real difference comes with its SR300 Multi-Timbre Strainer that features three individually tunable 6-strand snappy wire snares. Each can be engaged or disengaged to further sculpt the sound of the drum.

Pearl's reliably durable Mastercast Hoops also add weight for increased projection.

"I got this idea from the Pearl Symphonic series snare drum and I fell in love with the idea of having three different snare settings on one drum."

- Dennis Chambers



DENNIS CHAMBERS

| | |
|----------------|------------------------------|
| DC1465S | 14" x 6.5" |
| SHELL | 4 ply Maple w/ 4ply Re-Rings |
| HOOPS | Mastercast (DC1410/DC1408S) |
| LUGS | STL100 |
| RODS | SST5047 |
| STRAINER | SR300 |
| SNARES | S051 (x3) Snappy Wire Snares |
| HEADS | (Evans) B14G12 / S14H30 |
| FINISH | #119 Matte Black Lacquer |

A Snare Fit for a Legend, Truly in a Class By Itself.



SIGNATURE SNARES

Capturing The Exclusive Sound of Drumming Legends



MATT HALPERN

| | |
|-----------------|--------------------------------|
| MH1460/B | 14" x 6" |
| SHELL | 1.5 mm Brass |
| HOOPS | Mastercast (DCB1410 / 1410S) |
| LUGS | STL55MH/B |
| RODS | SST5052 (20) |
| STRAINER | SR150B (U.S. Patent #9082376) |
| SNARES | SN1420I (U.S. Patent #7202405) |
| HEADS | Evans Heavyweight Dry |
| FINISH | Matte Black Lacquer |

A Snare Drum from the Outer Limits of the Edge.



JOEY JORDISON

| | |
|----------------|---------------------------------|
| JJ1365N | 13" x 6.5" |
| SHELL | 1 mm Steel |
| HOOPS | SuperHoop II (SHB1308B / 1308S) |
| LUGS | CL65B |
| RODS | SST5047 (16) |
| STRAINER | SR017B |
| SNARES | S029N |
| HEADS | REMO Coated (A) |
| FINISH | Matte Black Lacquer |

A Fierce, Ferocious, Fast Snare fit for a Metal Drumming Legend.



BRIAN FRASIER-MOORE

| | |
|-------------------|--------------------------------|
| BFM1455S/C | 14" x 5.5" |
| SHELL | 12ply (15mm) Gum / Maple / Gum |
| HOOPS | Mastercast (DC1410 / 1410S) |
| LUGS | CL55 |
| RODS | T062 (20) |
| STRAINER | SR150 (U.S. Patent #9082376) |
| SNARES | SN1442I (U.S. Patent #7202405) |
| HEADS | Evans Power Center |
| FINISH | Gloss Gumwood Natural Burst |

A Truly Inspiring Snare Drum.



MATT MCGUIRE

| | |
|------------------|--------------------------------|
| MM1465S/C | 14" x 6.5" |
| SHELL | 1 mm Steel |
| HOOPS | SuperHoop II (SH1410 / 1410S) |
| LUGS | CL65 |
| RODS | T061 (20) |
| STRAINER | SR017 |
| SNARES | SN1420I (U.S. Patent #7202405) |
| HEADS | Evans Power Center |
| FINISH | Matte Black Lacquer |

Introducing The World's First "SMART" Snare Drum.



IAN PAICE

| | |
|---------------|-------------------------------|
| IP1465 | 14" x 6.5" |
| SHELL | 1 mm Beaded Steel |
| HOOPS | SuperHoop II (SH1410 / 1410S) |
| LUGS | TB65 |
| RODS | SST5042 (20) |
| STRAINER | SR017 |
| SNARES | S022N |
| HEADS | REMO Coated (A) |
| FINISH | Chrome |

A Timeless, Innovative Collaboration with a True Rock Legend.



OMAR HAKIM

| | |
|---------------|--------------------------------|
| OH1350 | 13" x 5" |
| SHELL | 6 ply (7.5mm) African Mahogany |
| HOOPS | SuperHoop II (SH1308 / 1308S) |
| LUGS | CL55 |
| RODS | SST5047 (16) |
| STRAINER | SR150 (U.S. Patent #9082376) |
| SNARES | S029N |
| HEADS | REMO Coated (A) |
| FINISH | #140 Natural Mahogany |

A "Power Piccolo" for a Sonic Blend of Power, Projection and Tonal Color.



HYBRID EXOTIC & ULTRA CAST

SPACE AGED PRECISION THROUGH ADVANCED SNARE CRAFTING.

For the ultimate in power and prestige, Pearl's Ultracast Aluminum Snares and limited Hybrid Exotic models offer stark, head-turning voices that stick out from the crowd.



Quick, yielding snap with heavy midrange overtones.
HEP1450



Lively blend of throaty snare holler and punchy projection.
HEK1465



UCA1450/B



UCA1465/B

| | |
|----------------|---|
| HEP1450 | 14" x 5" |
| SHELL | VectorCast |
| HOOPS | SuperHoop II (SH1410 / 1410S) |
| LUGS | STL100 |
| RODS | SST5047 (20) |
| STRAINER | SR1000 (U.S. Patents #7220905 #7365256) |
| SNARES | SN1420C (U.S. Patent #7202405) |
| HEADS | REMO Coated (A) |

| | |
|----------------|---|
| HEK1465 | 14" x 6.5" |
| SHELL | 6 ply (7.5 mm) Kapur w/Inner Fiberglass |
| HOOPS | SuperHoop II (SH1410 / 1410S) |
| LUGS | STL100 |
| RODS | SST5047 (20) |
| STRAINER | SR1000 (U.S. Patents #7220905 #7365256) |
| SNARES | SN1420D (U.S. Patent #7202405) |
| HEADS | REMO Coated (A) |
| FINISH | #308/Piano Black w/Pearl Inlay |

| | |
|------------------|--|
| UCA1450/B | 14" x 5" |
| SHELL | 3mm Cast Aluminum w/Reinforcement |
| HOOPS | SuperHoop II (SHB1410 / 1410S) |
| LUGS | TB50B |
| RODS | SST5042 (20) |
| STRAINER | SR1000B (U.S. Patents #7220905 #7365256) |
| SNARES | SN1420C (U.S. Patent #7202405) |
| HEADS | Remo Coated (A) |

| | |
|------------------|--|
| UCA1465/B | 14" x 6.5" |
| SHELL | 3mm Cast Aluminum w/Reinforcement |
| HOOPS | SuperHoop II (SHB1410 / 1410S) |
| LUGS | TB65B |
| RODS | SST5042 (20) |
| STRAINER | SR1000B (U.S. Patents #7220905 #7365256) |
| SNARES | SN1420C (U.S. Patent #7202405) |
| HEADS | Remo Coated (A) |

STAVECRAFT

A startling addition to any pro drummer's soundscape, each StaveCraft shell starts from two layers of meticulously beveled solid wood staves. Dado-Loc, an old world principal exclusive to these snares, inserts a solid segment of contrasting wood into the center Dado channel formed by each stave. This solid fusion of hardwoods is lathed to a perfectly round 25mm thickness for unparalleled volume and power.



Peak high-end sonic dominance with lively overtone.
SCD1450AW



Dense, strident snare power with full-compass swagger.
SCD1465AW

| | |
|------------------|---|
| SCD1450AW | 14" x 5" |
| SHELL | 25mm Dual Ash Wood Stave w/ Makha DadoLoc |
| HOOPS | Mastercast (DC1410 / 1410S) |
| LUGS | STL55L |
| RODS | SST5042 (20) |
| STRAINER | SR150 (U.S. Patent 9082376) |
| SNARES | SN1420I (U.S. Patent #7202405) |
| HEADS | Remo USA CS Black Dot Clear |

| | |
|------------------|---|
| SCD1465AW | 14" x 6.5" |
| SHELL | 25mm Dual Ash Wood Stave w/ Makha DadoLoc |
| HOOPS | Mastercast (DC1410 / 1410S) |
| LUGS | STL65 |
| RODS | SST5042 (20) |
| STRAINER | SR150 (U.S. Patent 9082376) |
| SNARES | SN1420I (U.S. Patent #7202405) |
| HEADS | Remo USA CS Black Dot Clear |



Quick, tight high-range tonal power.
SCD1450TO



Sensitive, centered low-overtone drive.
SCD1465TO

| | |
|------------------|--|
| SCD1450TO | 14" x 5" |
| SHELL | 25 mm Dual Thai Oak Stave w/ Makha DadoLoc |
| HOOPS | Mastercast (DC1410 / 1410S) |
| LUGS | STL55L |
| RODS | SST5042 (20) |
| STRAINER | SR150 (U.S. Patent 9082376) |
| SNARES | SN1420I (U.S. Patent #7202405) |
| HEADS | Remo USA CS Black Dot Clear |

| | |
|------------------|--|
| SCD1465TO | 14" x 6.5" |
| SHELL | 25 mm Dual Thai Oak Stave w/ Makha DadoLoc |
| HOOPS | Mastercast (DC1410 / 1410S) |
| LUGS | STL65 |
| RODS | SST5042 (20) |
| STRAINER | SR150 (U.S. Patent 9082376) |
| SNARES | SN1420I (U.S. Patent #7202405) |
| HEADS | Remo USA CS Black Dot Clear |

DUOLUXE

THE WORLD'S FIRST INLAID BRASS SNARE DRUM

Pearl celebrates three-quarters of a century of iconic drum sounds with Duoluxe, a modern take our legendary Jupiter snare drum. This classic combination of a chrome-over-brass alloy shell and our trademark dual inverted shell beads is augmented with two finish bands of Nicotine White Marine Pearl inlay. This gives the shell a singular look and adds tonal nuance to its unbridled sound.



Bold and crisp with short midrange overtone.
DUX1450BR



Fierce and centered mid-to-low sustain.
DUX1465BR

| | |
|------------------|--|
| DUX1450BR | 14" x 5" |
| SHELL | 1mm Dual-Beaded Brass / Chrome |
| HOOPS | SuperHoop II (SH1410B/1410S) |
| LUGS | BSL55 |
| RODS | SST5042 (20) |
| STRAINER | SR017 |
| SNARES | SN1420I (U.S. Patent #7202405) |
| HEADS | REMO Coated (A) |
| FINISH | INLAY: #405 Nicotine White Marine Pearl (x2) |

| | |
|------------------|--|
| DUX1465BR | 14" x 6.5" |
| SHELL | 1mm Dual-Beaded Brass / Chrome |
| HOOPS | SuperHoop II (SH1410B/1410S) |
| LUGS | BSL55 |
| RODS | SST5055 (20) |
| STRAINER | SR017 |
| SNARES | SN1420I (U.S. Patent #7202405) |
| HEADS | REMO Coated (A) |
| FINISH | INLAY: #405 Nicotine White Marine Pearl (x2) |



Cracking tonal pop with short midrange hum.
SCD1450MK



Thick, cavernous sonic body with cutting punch.
SCD1465MK

| | |
|------------------|--|
| SCD1450MK | 14" x 5" |
| SHELL | 25 mm Dual Makha Stave w/ Thai Oak DadoLoc |
| HOOPS | Mastercast (DC1410 / 1410S) |
| LUGS | STL55L |
| RODS | SST5042 (20) |
| STRAINER | SR150 (U.S. Patent 9082376) |
| SNARES | SN1420I (U.S. Patent #7202405) |
| HEADS | Remo USA CS Black Dot Clear |

| | |
|------------------|--|
| SCD1465MK | 14" x 6.5" |
| SHELL | 25 mm Dual Makha Stave w/ Thai Oak DadoLoc |
| HOOPS | Mastercast (DC1410 / 1410S) |
| LUGS | STL65 |
| RODS | SST5047 (20) |
| STRAINER | SR150 (U.S. Patent 9082376) |
| SNARES | SN1420I (U.S. Patent #7202405) |
| HEADS | Remo USA CS Black Dot Clear |

UTILITY

VERSATILE DRUMS FOR SECONDARY EFFECTS

MODERN UTILITY snare drums are vital instruments. Well-appointed tools of the trade crafted for the informed, current drummer to make the gig great. Priced for the active working player, Modern Utility snares are available in both 100% Maple and Beaded Steel. Flexible enough to add to any setup and strong enough to stand up to constant play, each model has a cool, versatile vibe. Featuring our CL arch lugs and smooth SR700 snare strainer for precise tunability.

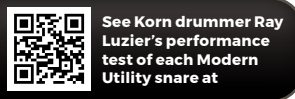

See Korn drummer Ray Luzier's performance test of each Modern Utility snare at



MUS1480M/C



MUS1410FM/C



Leg Brackets:
FTB07 (x3)



MUS1455M/C



MUS1465M/C



MUS1350M/C



MUS1270M/C

| MUS1480M | 14" x 8" |
|----------|--------------------------------------|
| SHELL | 6 ply (5.4mm) Maple |
| HOOPS | 1.6mm Steel (RH1408 / 1408S) |
| LUGS | CL100 |
| RODS | TR5047 (16) |
| STRAINER | SR700 |
| SNARES | SNW1420 |
| HEADS | REMO UT Coated (A) |
| FINISH | #224 Matte Natural, #227 Satin Black |

| MUS1410FM | 14" x 10" |
|-----------|--------------------------------|
| SHELL | 6 ply (5.4mm) Maple |
| HOOPS | 1.6mm Steel (RH1408 / 1408S) |
| LUGS | CL100 |
| RODS | TR5047 (16) |
| STRAINER | SR017 |
| SNARES | SNW1420 |
| HEADS | REMO UT Coated (A) w/Ring Mute |
| FINISH | #220 Satin Brown |

| MUS1455M | 14" x 5.5" |
|----------|--------------------------------------|
| SHELL | 6 ply (5.4mm) Maple |
| HOOPS | 1.6mm Steel (RH1408 / 1408S) |
| LUGS | CL55 |
| RODS | TR5052 (16) |
| STRAINER | SR700 |
| SNARES | SNW1420 |
| HEADS | REMO UT Coated (A) |
| FINISH | #224 Matte Natural, #227 Satin Black |

| MUS1465M | 14" x 6.5" |
|----------|--------------------------------------|
| SHELL | 6 ply (5.4mm) Maple |
| HOOPS | 1.6mm Steel (RH1408 / 1408S) |
| LUGS | CL65 |
| RODS | TR5047 (16) |
| STRAINER | SR700 |
| SNARES | SNW1420 |
| HEADS | REMO UT Coated (A) |
| FINISH | #224 Matte Natural, #227 Satin Black |

| MUS1350M | 13" x 5" |
|----------|--------------------------------------|
| SHELL | 6 ply (5.4mm) Maple |
| HOOPS | 1.6mm Steel (RH1308 / 1308S) |
| LUGS | CL55 |
| RODS | TR5047 (16) |
| STRAINER | SR700 |
| SNARES | SNW-1316 |
| HEADS | REMO UT Coated (A) |
| FINISH | #224 Matte Natural, #227 Satin Black |

| MUS1270M | 12" x 7" |
|----------|--------------------------------------|
| SHELL | 6 ply (5.4mm) Maple |
| HOOPS | 1.6mm Steel (RH1206 / 1206SL) |
| LUGS | CL65 |
| RODS | TR5057 (12) |
| STRAINER | SR700 |
| SNARES | SNW-1216 |
| HEADS | REMO UT Coated (A) |
| FINISH | #224 Matte Natural, #227 Satin Black |

EFFECTS SNARES



M1060 10" x 6"

| | |
|----------|--------------------------------|
| SHELL | 6 ply (7.5mm) Maple |
| HOOPS | SuperHoop II (SH-1006 / 1006S) |
| LUGS | CL-65 |
| RODS | SST-5047 (12) |
| STRAINER | SR-018 |
| SNARES | S-032N |
| HEADS | REMO Coated (A) |
| FINISH | #102 Natural Maple |



M1270 12" x 7"

| | |
|----------|---------------------------------|
| SHELL | 8 ply (10.0 mm) Maple |
| HOOPS | 1.6mm Steel (RIM-1208B / 1208S) |
| LUGS | CL-100 |
| RODS | SST-5047 (16) |
| STRAINER | SR-018 |
| SNARES | S-031N |
| HEADS | REMO Coated (A) |
| FINISH | #114 Liquid Amber |



SFS1335B 13" x 3.5"

| | |
|----------|--------------------|
| SHELL | Steel |
| HOOPS | 1.6mm Steel |
| LUGS | MSFL35 |
| RODS | RSHI-3235 |
| STRAINER | SR02MSFL/SR02EMSFL |
| SNARES | SN-13MSFL |
| HEADS | JH-13C |
| FINISH | Matte Black |

PICCOLO



S1330B 13" x 3"

| | |
|----------|--------------------------------|
| SHELL | 1mm Brass |
| HOOPS | 1.6mm Steel (RIM1308B / 1308S) |
| LUGS | CL05 |
| RODS | T055 (16) |
| STRAINER | SR018 |
| SNARES | S029N |
| HEADS | REMO Coated (A) |
| FINISH | --- |



S1330B 13" x 3"

| | |
|----------|--------------------------------|
| SHELL | 1mm Steel |
| HOOPS | 1.6mm Steel (RIM1308B / 1308S) |
| LUGS | CL05 |
| RODS | T055 (16) |
| STRAINER | SR018 |
| SNARES | S029N |
| HEADS | REMO Coated (A) |
| FINISH | Black Finish |



M1330 13" x 3"

| | |
|----------|---------------------------------------|
| SHELL | 6 ply (7.5 mm) Maple |
| HOOPS | 1.6mm Steel (RIM1308B / 1308S) |
| LUGS | CL05 |
| RODS | T055 (16) |
| STRAINER | SR018 |
| SNARES | S029N |
| HEADS | REMO Coated (A) |
| FINISH | #114 Liquid Amber, #102 Natural Maple |

FIRECRACKER



FCP1250 12" x 5"

| | |
|----------|--------------------------------|
| SHELL | 8 ply (10.0 mm) Poplar |
| HOOPS | 1.6mm Steel (RIM1206 / 1206SL) |
| LUGS | CL55 (with Steel Nut) |
| RODS | T061L (12) |
| STRAINER | SR018 |
| SNARES | S031 |
| HEADS | PTH12C |
| FINISH | #271 Ebony Mist |



FCS1050 10" x 5"

| | |
|----------|--------------------------------|
| SHELL | Steel |
| HOOPS | 1.6mm Steel (RIM1006 / 1200SL) |
| LUGS | CL55 (with Steel Nut) |
| RODS | T061L (12) |
| STRAINER | SR018 |
| SNARES | S032 |
| HEADS | PTH10C |
| FINISH | Chrome Plating |

EFFECTS

THE IGNITER To capture the searing energy of drumming for a new generation of players, Pearl collaborated with viral video drummer Casey Cooper to create The Igniter. Specifically created to instantly improve the sound of any student drum kit, it's a fantastic value to keep the fire of drumming burning bright!



| CC1450S/C | 14" x 5" |
|-----------|------------------------------|
| SHELL | 6 ply (6.8mm) Poplar / Maple |
| HOOPS | 1.6mm Steel (RH1408 / 1408S) |
| LUGS | CL55 |
| RODS | TR5047 (16) |
| STRAINER | SR700 |
| SNARES | SNW1420 |
| HEADS | REMO UT Coated (A) |
| FINISH | Artisan II Flame Finish |

COLLABORATION CASEY COOPER @COOP3RDRUMM3R



e/TRADITIONAL CONFIGURATION

10", 12" and 14" toms, a 14" snare, and PUREtouch Kick Pad. PUREtouch Cymbals, ICON e-Rack, MDL1 Module, EM53T



e/HYBRID CONFIGURATION

EMHWP
The foundation of the e/MERGE electronic drum set is a custom designed, chrome plated ICON e-Rack system.

10", 12" and 14" toms, 14" snare, and 18" acoustic bass drum. PUREtouch Cymbals, ICON e-Rack, MDL1 Module, EM53HB

e/MERGE

**NOT JUST A NEW STANDARD.
A NEW SOUND. A NEW FEEL. AND, A
COMPLETELY NEW E-DRUMMING EXPERIENCE.**

e/MERGE is about change, and change in the e-drum market has been way overdue. When we looked closely at every aspect of the current e-drumming experience with KORG, together we knew we could make a dramatic difference. And that difference begins with the all new e/MERGE module. Simple yet elegant in design, the e/MERGE MDL1 module features a full library of high definition, natural, organic and minimally processed acoustic Pearl drums. We then added the very best electronic, world, orchestral and specialty percussion sounds from KORG's vast library of pristine quality samples. But, the module is only part of the change.

There are three key elements that separate e/MERGE from anything that has come before. The MDL1 e/MERGE Module, KORG's amazing WAVE TRIGGER TECHNOLOGY and Pearl's acoustic-like PUREtouch electronic pads and cymbals combine to create an exceptional e-drumming experience.



e/MERGE MDL1 MODULE Simple, straight forward yet extremely powerful, the MDL1 module offers, a pair of powerful multicore processors, a full library of acoustic Pearl drums recorded in one of the world's most renowned studios, pristine samples from KORG's library and the variety of routing options every e-drummer needs.



WAVE TRIGGER TECHNOLOGY This ultra-fast and highly sensitive technology partially based upon KORG's groundbreaking Wave Drum allows even your stick choice to make a discernible difference in the sound of your drum. Wave Trigger Technology speed adds a realism to the playing experience never before available to the e-drummer.

PUREtouch

PUREtouch PADS & CYMBALS
Perfectly sized pads designed to replicate the ultimate acoustic-like response. PUREtouch features layer upon layer of specially designed materials each selected for a specific quality that together create an e-experience never before possible.

MODULE SPECIFICATIONS



| | |
|----------------------------|---|
| SOUND GENERATOR | 2 CPU (4 core + 2 core) |
| POLYPHONY | 128 Voices |
| VOICE | 700 HD Sound Library |
| DRUM KIT | 35 HD Kits |
| EFFECTS | 36 |
| SONG RECORDING TYPE | 44.1kHz, 16 Bit WAV |
| SONG RECORDING TIME | Approximately 12 Hours |
| CLICK TEMPO | BPM 30 - 300 |
| BEAT | 1/2 - 24/2, 1/4 - 24/4, 1/8 - 24/8, 1 - 24/8T, 1/16 - 24/16 (T=Triplet) |
| CLICK VOICES | 10 |
| CONTROLLERS | Knobs and Ambient Slider Control |
| DISPLAY | 3.25" x 1" Graphic LCD |
| CONNECTORS | Master Out L/Mono & R Direct Out (8) Headphones Out Aux In TRS Mini Main Trigger inputs (DB-25 Connector) Accessory Inputs (3) |
| MIDI | USB to PC Port (Transport USB Audio & MIDI Data) USB-A (for WAV files and Settings Data) |
| POWER SUPPLY | MIDI Output |
| DIMENSIONS, WEIGHT | 100-120V, 50-60Hz, Switching Power Supply 2.2lbs, 9" W x 7.5" D x 2" H |

MIMIC PRO

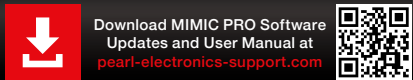

Powered by Slate



MIMP24B

MIMIC PRO POWERED BY SLATE

STATE OF THE ART FEATURES:

- 7" IPS Touch Screen with Programmable Data Wheel
- 120GB Solid State drive
- 16 Dual Zone Inputs
- 16 Programmable Audio Outputs
- MIDI In and Out
- High Quality Digital to Analog Converters
- Two completely separate mixers for headphone and Main outs (Drummer gets a personal mix with and without effects independent of Main outputs)
- Import Wave, Aiff or MP3 sound files
- Compatible with most pads on the market
- Steven Slate Drums 5 Library
- 24 bit multi channel sample library with separate adjustment of Close, Overhead and Room mics
- Onboard effects include EQ, Compression, Reverb with Room Sizes
- Individual Cymbal Volume Adjustments for Bell, Bow, Edge, Chik and Splash
- All AUX and Cymbal inputs have choke function
- Supports triple and dual zone cymbals and dual zone hi hat
- SD card slot and USB
- Additional Instruments and Libraries will be available
- Stereo Aux In and Onboard Metronome
- Internal Recording for Loops and/or Performances

**THE MOST AMAZING
DRUM MODULE
THE WORLD HAS
EVER KNOWN.**

**SERIOUSLY,
IT'S THAT GOOD.**



Superior sound, accurate triggering and connectivity are the most important features of a drum module. Pearl Drums and Steven Slate have joined forces to create "Mimic Pro" - the world's most advanced percussion sound source for studio and live performance applications.

At the heart of this ground breaking unit is the new Steven Slate 5 drum library that features multi-channel drum samples recorded in world class studios. Each instrument supports adjustment of Attack, Sustain, Release, Tune, Pan and volume. Instead of substituting digital effects to create ambience, these instruments use the actual ambient recordings with separate adjustment of close, overhead and room mics.

Mimic Pro is the first drum module to implement a 7" IPS touch screen and the first to offer 2 mixers for independent headphone and front house outputs. Now that the drummer is responsible for triggering loops and other sounds for a performance, Mimic Pro can import audio files to trigger from your pads.

Storage is no longer a problem with Mimic's 120GB Solid State Drive and lightning fast loading time. Speaking of connectivity, Mimic Pro is compatible with Pearl TruTrac pads and a host of pads from other manufacturers. Top that off with sixteen audio outs, 16 Trigger inputs, independent SD card Slot, USB and Midi In & Out, Stereo Aux input and you would be hard pressed to find a better option for today's musician.



malletSTATION

The World's First 3.0 Octave Adjustable Range
Electronic Mallet Controller

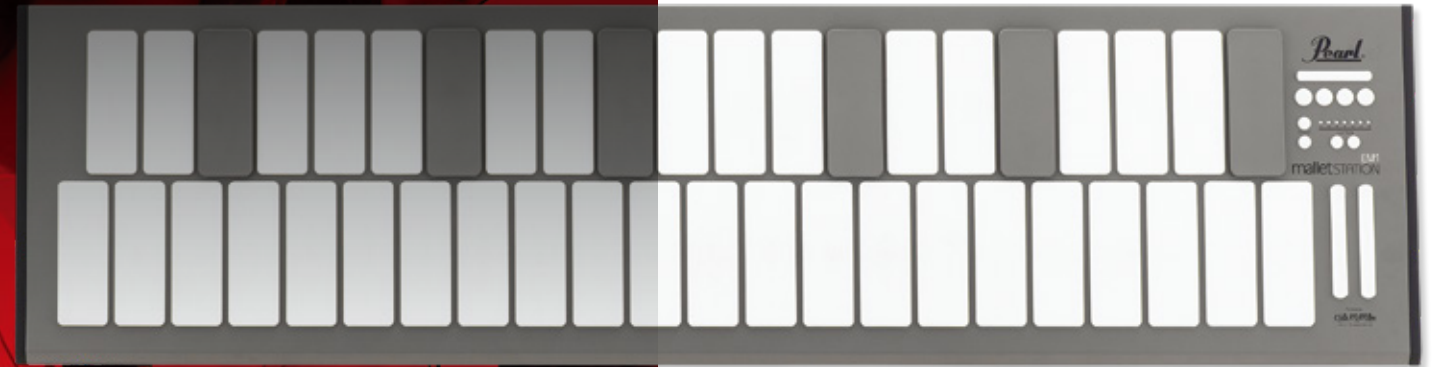

Shown Mounted on Vibraphone with Field Frame

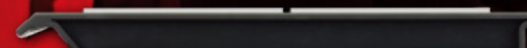

Sleek, modern design with an ultra thin 1.6" profile

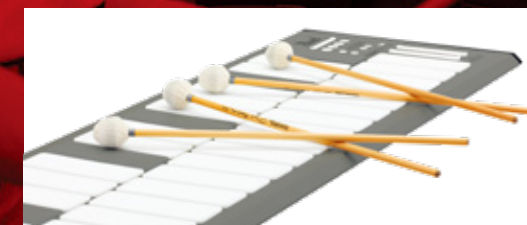

1.75" x 5" Soft Silicone Keys powered by KMI Smart Fabric Sensor Technology

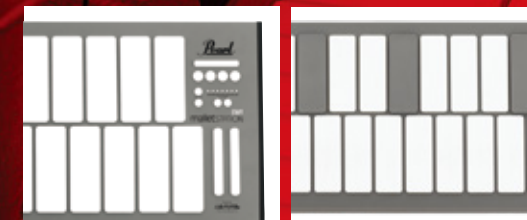

Software Assignable Control Panel with 3 Faders, 4 Buttons, plus Low Note and Octave Shift (U.S. Patent 10311841)

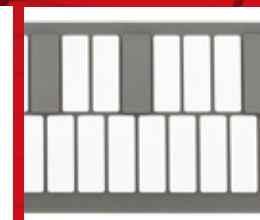

Moveable Accidental "Gap Caps" for visual cues when low note range is adjusted



Jack panel with USB MIDI, MIDI expander port, and 3 MIDI assignable 1/4" pedal inputs



Optional Dual Module Mounts allow malletSTATION to easily mount on racks, stands, and field frames

malletSTATION™ EM1

PRACTICE, PERFORM, COMPOSE ANYWHERE.

- USB Powered MIDI Mallet Keyboard Controller
- Universal Compatibility through phone/tablet/laptop
- Tech-Forward Design featuring KMI Smart Fabric Sensors
- Low Note, Adjustable, User defined
- Customizable mallet dampening and aftertouch modes for realistic performance techniques
- Natural feeling soft silicone keys, all-weather playing surface
- Assignable buttons and faders for customized control and functions
- Three assignable pedal inputs for expression and sustain
- Hybrid Aluminum and Steel Chassis design for durability and stability
- Optional MIDI Expander to use external MIDI Hardware (sold separately)
- Flexible mounting on desktop, X-stand, or module mounts (sold separately)
- Mounting plates, stands, cases, covers, and other peripherals (available separately)

- 43, 1.75" x 5" soft silicone keys
- 3 faders and 4 buttons, MIDI assignable
- 3 MIDI assignable 1/4" pedal inputs
- Bottom Note Range Shift up/down buttons
- Octave up/down buttons
- 1.6" H x 12.6" W x 49" L
- 22.5 lbs

Pearl once again redefines the electronic percussion experience by introducing the revolutionary EM1 malletSTATION adjustable range electronic mallet controller.

The EM1 malletSTATION is a 3.0 octave adjustable range electronic mallet controller designed for all levels of player, from the beginning student through the gigging professional. The adjustable range function allows you to set the fundamental diatonic note of the instrument to what you need—low D xylophone? No problem! Powered exclusively by USB Bus Power, the malletSTATION is designed to be used with Mac, PC, iPad, iPhone, and Android devices, making it the first truly portable mallet percussion controller on the market.

Designed in collaboration with Keith McMillen Instruments, malletSTATION's tech-forward design features KMI's Smart Fabric Sensor technology allowing the silicone bar material to have an extremely sensitive, natural response, including mallet dampening and aftertouch control, and all can be easily tailored to your individual playing style. The EM1 features a master control section, with 3 programmable faders, 4 programmable buttons, and the fixed function low note and octave shift buttons. In addition, three assignable pedal inputs allow for flexibility in performance such as sustain, expression, or any MIDI parameter of your choice. These controls are fully programmable through a software editor so changing your configuration is as easy as clicking a mouse.

This is the controller that will grow with you throughout your playing career—from music apps on your phone or tablet, to professional digital audio workstations and sound libraries—your sounds and even the instruments you play are only limited by the software you run.

ELIMINATOR DEMON XR



SEE the **Demon XR** in action with design partner George Kollias and John Longstreth

The Ultimate In Speed, Rebound, And Accuracy.



ENHANCED REBOUND STROKE
Eases High Tempo Single and Double Strokes



DIRECT DRIVE
Extreme Speed and Precise, Resistance-Free Playability



SLEEK LONGBOARD
Improves Double Stroke Response

MACHINED ALUMINUM CONSTRUCTION
Delivers Light, Efficient Action

Single Pedal Complete
P3500D

THE DIRECT-DRIVE TRIPLE THREAT: X-TREME SPEED. X-TREME REBOUND. X-TREME ACCURACY.

Developed in conjunction with the world's top drumming talents for speed and enhanced rebound in extreme musical situations, The Pearl Demon XR Bass Drum Pedal is your direct path to rapid fire bass drum performance.

Delivering the ultimate in Speed, Rebound, and Accuracy, the Pearl Demon XR (for X-treme Response) Bass Drum Pedal is a true Triple Threat in bass drum pedal performance.

P3500D BASS DRUM PEDAL

| | |
|--------------------|---|
| DRIVE | Direct Drive |
| FOOT BOARD | Longboard Machined Aluminum |
| DRIVE BEARINGS | NiNJA Low-Friction Extreme High-Tension Spring (Normal Spring included) |
| SPRING | Extreme Impact Beater (B350XR) |
| BEATER | Click-Lock |
| TENSION ADJUSTMENT | Included |
| CASE | Pivoting Hoop Clamp |
| HOOP CLAMP | |

P3502D DOUBLE BASS DRUM PEDAL

| | |
|--------------------|---|
| DRIVE | Direct Drive |
| FOOT BOARD | Longboard Machined Aluminum |
| DRIVE BEARINGS | NiNJA Low-Friction Extreme High-Tension Spring (Normal Spring included) |
| SPRING | Extreme Impact Beater (B-350XR) |
| BEATER | Click-Lock |
| TENSION ADJUSTMENT | Included |
| CASE | Pivoting Hoop Clamp |
| HOOP CLAMP | Z-Link Drive Shaft |



Z-LINK
Universal Linkage



X-TREME IMPACT BEATER
Sharp Attack and Low End

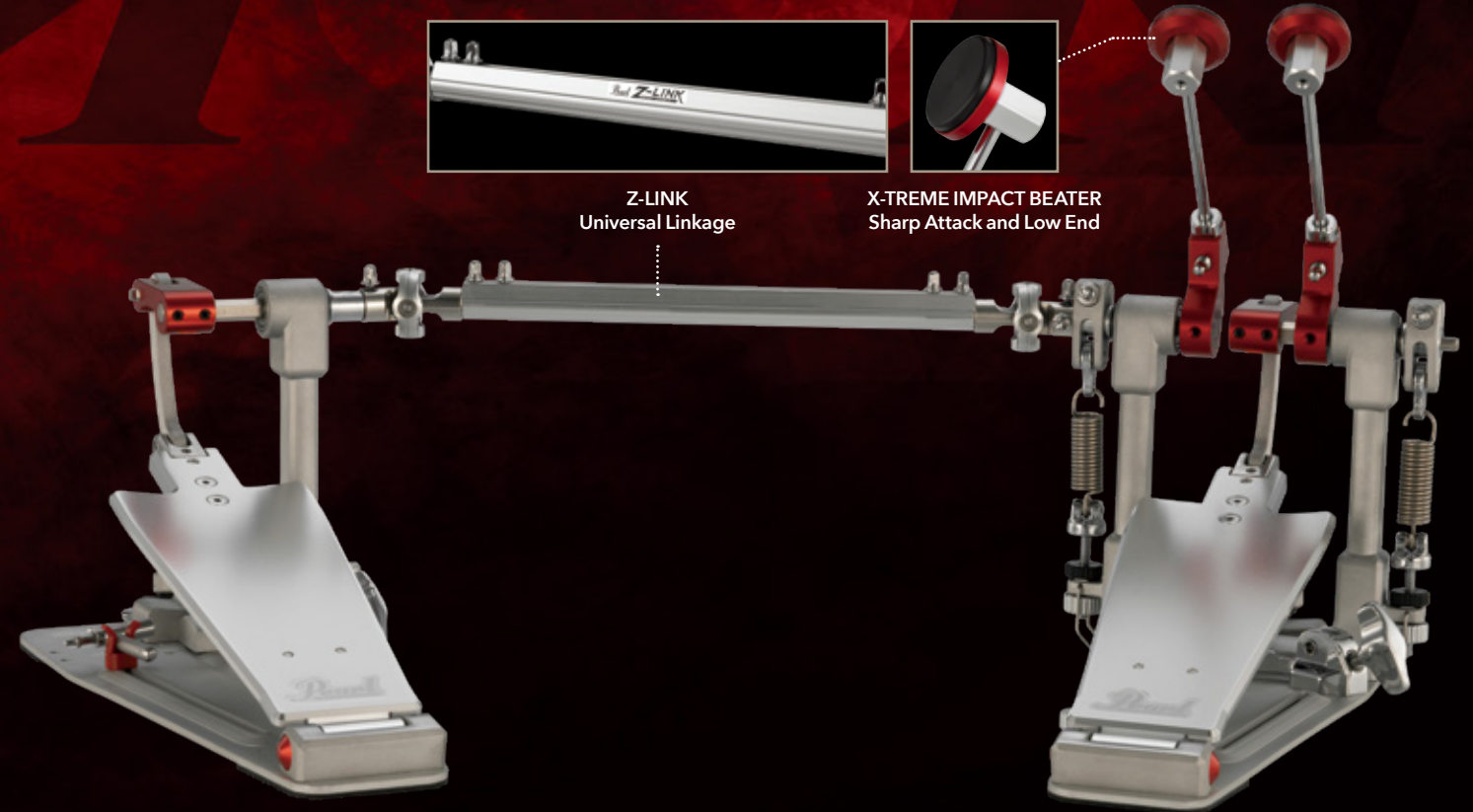

Double Pedal Complete
P3502D



X-TREME SPEED

Its streamlined machine shop design is the result of a two-year research and development project with drummer George Kollias, and delivers a faster, smoother stroke in action.



X-TREME REBOUND

The key to higher playing speed is in its enhanced rebound action and interchangeable Extreme Spring. This exclusive feature makes repeated strokes in the most extreme musical situations effortless.

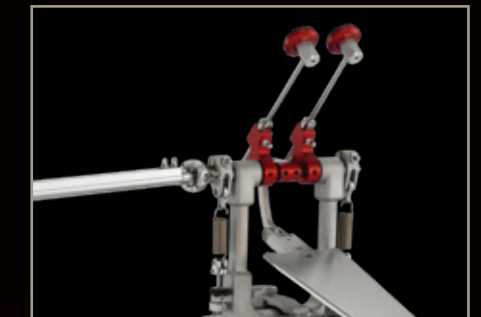

X-TREME ACCURACY

Primed for the high tempo technicality, the Pearl Demon XR is perfect for any drumming style where precision and endurance is key.

DEMON PEDALS

The Fastest, Smoothest, Most Powerful Pedals in the World

DEMON DRIVE UNLEASH THE DEMON

Demon Drive's lightning fast power and silky smooth finesse make it the choice of the drumming world's most prolific players. Featuring an amazing array of adjustable features, from beater angle, traction plate grip, and footboard height and angle, Demon Drive truly becomes an extension of your body. Its totally modular design makes it configurable in a variety of single and double pedal setups. Unleash the Demon and find out what custom feel is all about.



U.S. Patent #7579540

A choice of 2 positions for a finesse or power feel. Simply loosen the clamshell to change position.

- Single Pedal Complete P3000D
- Double Pedal Complete (right footed) P3002D
- Double Pedal Conversion Kit (right footed) P3001D
- Double Pedal Complete (left footed) P3002DL

- Demon Drive (Shown in Shortboard Set Up) P3000D

Demon Drive
(Shown in Shortboard Set Up)
P3000D

CONTROL CORE BEATERS

INDEPENDENT BEATER ANGLE AND FOOTBOARD HEIGHT ADJUSTMENTS

ADJUSTABLE TRACTION PLATE

Direct Drive Double Pedal
(Shown in Longboard Setting)
P3002D

DUO-DECK FOOTBOARD

P3000D / P3002D DEMON DRIVE

| | |
|--------------------|-----------------------|
| DRIVE | Direct Drive |
| FOOT BOARD | Duo-Deck Convertible |
| DRIVE BEARINGS | NiNJA Low-Friction |
| BEATER | Control Core |
| TENSION ADJUSTMENT | Click-Lock |
| FOOTBOARD ANGLE | Infinitely Adjustable |
| BEATER ANGLE | Infinitely Adjustable |
| CASE | Included |
| HOOP CLAMP | Pivoting Hoop Clamp |

DEMON DRIVE BEATER w/ Control Core Elastomer Center. Reduces impact vibration. (U.S. Patent #7626108)

NiNJA BEARINGS Designed for Pro Skateboarding, each bearing features micro-polished balls for minimal friction and unmatched speed.

NiNJA

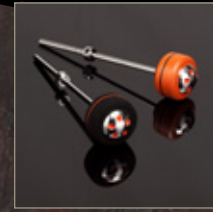

DIRECT LINK Dual position adjustment for LIGHT or HEAVY feel, creating a seamless link between your foot and the bass drum.



CLICK-LOCK Secures spring tension in high impact play. (U.S. Patent #7754953)



DUO-DECK FOOTBOARD The world's first convertible footboard can switch from a traditional shortboard to a longboard pedal in seconds. (U.S. Patent #7626107)

ELIMINATOR DEMON PEDALS

HEAVENLY FEEL... WICKEDLY FAST

DEMON CHAIN TRADITIONAL FEEL AND POWER OF A CHAIN

An innovative combination of Demon Drive speed and traditional chain drive feel, the Demon Chain's Perfect Circle cam delivers smooth, consistent response throughout the stroke for pinpoint accuracy and control. A high performance package for the driven power drummer.

PERFECT CIRCLE CAM

PIVOTING HOOP CLAMP

MULTI FUNCTION DRUM KEY

- Single Pedal Complete P3000D
- Double Pedal Complete (right footed) P3002D
- Double Pedal Conversion Kit (right footed) P3001D
- Double Pedal Complete (left footed) P3002DL

- Demon Chain (Shown in Longboard Set Up) P3000C

PERFECT CIRCLE CAM Its racing inspired lines transfer energy from your foot into the head with minimal mass and maximum speed.

POWER CHAIN This ultra lightweight, dual linkage Chain features low friction rollers for power and dependability.

BEATER HEIGHT ADJUSTMENT

NiNJA BEARINGS

Chain Drive Double Pedal (Shown in Shortboard Setting) P3002C



Z-LINK DRIVE SHAFT Delivering the same precise action of the primary pedal in the secondary pedal, the Z-Link features hand assembled, CNC machined construction. Features Pearl's exclusive Zero Latency Universal Joints, and precision radial ball bearings.

P3000C / P3002C DEMON CHAIN

| | |
|--------------------|--------------------------------------|
| DRIVE | Ultralight Chain |
| FOOTBOARD | Duo-Deck Convertible |
| DRIVE BEARINGS | NiNJA Low-Friction |
| DRIVE CAM | Perfect Circle "Linear Response" Cam |
| BEATER | Control Core |
| TENSION ADJUSTMENT | Click-Lock |
| FOOTBOARD ANGLE | Infinitely Adjustable |
| BEATER ANGLE | Infinitely Adjustable |
| CASE | Included |
| HOOP CLAMP | Pivoting Hoop Clamp |



ELIMINATOR : REDLINE

The Key to Ultimate Bass Drum Performance

ELIMINATOR REDLINE

CHOOSE A CAM REDLINE YOUR PERFORMANCE

The world's only pedal featuring the Patented Interchangeable Cam System, Eliminator: Redline's virtually unlimited tunability lets you lock in personally tuned feel, power, and speed. Like having four pedals in one, Redline pushes the boundaries of bass drum performance by fusing the power and flexibility of Pearl's original Eliminator with the fluid speed of our Demon series pedals.

CHAIN OR BELT DRIVE

*Shown w/ Optional Red Cam

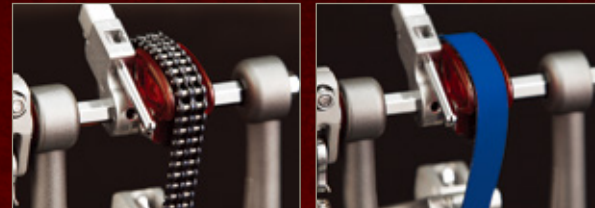

The sprocketless double chain drive on the Eliminator Redline (P2050C) provides super smooth action with powerful and precise feel. The Eliminator Belt Drive model (P2050B) provides a very comfortable, natural feel similar to a direct-drive system.

Eliminator: Redline
Single Pedal, Chain Drive
P2050C

| | P2050C ELIMINATOR: REDLINE CHAIN | P2052C ELIMINATOR: REDLINE DOUBLE PEDAL, CHAIN | P2050B ELIMINATOR: REDLINE, BELT | P2052B ELIMINATOR: REDLINE DOUBLE PEDAL, BELT |
|--------------------|-------------------------------------|---|-------------------------------------|--|
| Drive | Sprocketless Double Chain | Sprocketless Double Chain | Steel-Reinforced Rubber Strap | Steel-Reinforced Rubber Strap |
| FOOT BOARD | Redline Reversible Traction Plate | Redline Reversible Traction Plate | Redline Reversible Traction Plate | Redline Reversible Traction Plate |
| DRIVE BEARINGS | NiNJA Low-Friction | NiNJA Low-Friction | NiNJA Low-Friction | NiNJA Low-Friction |
| DRIVE CAM | Interchangeable Cam | Interchangeable Cam | Interchangeable Cam | Interchangeable Cam |
| BEATER | Control Core Quadbeater | Control Core Quadbeater | Control Core Quadbeater | Control Core Quadbeater |
| TENSION ADJUSTMENT | Click-Lock | Click-Lock | Click-Lock | Click-Lock |
| BEATER ANGLE | Uni-Lock Beater Angle Cam | Uni-Lock Beater Angle Cam | Uni-Lock Beater Angle Cam | Uni-Lock Beater Angle Cam |
| POWERSHIFTER | Three Position | Three Position | Three Position | Three Position |
| CASE | Included | Included | Included | Included |
| HOOP CLAMP | Roller Cam Hoop Clamp | Roller Cam Hoop Clamp | Roller Cam Hoop Clamp | Roller Cam Hoop Clamp |
| UNIVERSAL JOINT | --- | Length Adjustable, Latency-Free | --- | Length Adjustable, Latency-Free |

INTERCHANGEABLE CAM SYSTEM

Provides a choice of 6 different color-coded cams (4 included and 2 more optional). Quickly changes the power and feel of the pedal to suit your individual playing needs. Changing the cam is as simple as pushing the release button and snapping another in place.

Strong FEEL
Black
White
Blue
Purple (op)
Yellow (op)
Light Red

BEATER ACTION

BLACK CAMTBK
Linear action cam

WHITE CAMTWT
Oversized linear cam

BLUE CAMTBL
Progressive cam

RED CAMTRD
Radical progressive cam

PURPLE CAMPL
Aggressive action cam (Optional)

YELLOW CAMYL
Inverse action cam (Optional)

Eliminator: Redline
Double Pedal, Belt Drive
P2052B



Eliminator: Redline Series pedals come standard with Custom Carry bags.

Eliminator: Redline Double Pedal Chain Drive
(Shown w/ Included Red Cam Attached)
P2052C



POWERSHIFTER FUNCTION
By moving the foot board forward or back, our revolutionary PowerShifter function provides 3 positions to fine tune the power and feel of the pedal. Instantly change the drive angle leverage to create a light, regular, or strong feel.



NiNJA BEARINGS Developed by skateboarding engineers for the ultimate in fast, quiet performance, NiNJA Bearings incorporate state of the art micropolished steel balls for incredibly fast and smooth performance.



INDEPENDENT TRACTION GRIPS
Eliminator Redline's redesigned pedalboard features Pearl's exclusive reversible Traction Plate insert, allowing individual traction grip configuration to suit your exact playing requirements.



CLICK-LOCK SPRING ADJUSTMENT
w/ NEW Rotor Tension Cradle. Secures spring tension in high impact play. The counter spring adjustment's rolling cradle allows the spring to pivot with each stroke for less resistance. (U.S. Patent #7754953)



ZERO PLAY HINGE
Our proprietary stainless steel hinge provides maximum freedom of motion for blazing speed and prevents play between the footboard and heel. U.S. Patent #7179978



ROLLER CAM HOOP CLAMP
Mount Adjustment. Quickly adapts to a wide range of hoop thicknesses for the smoothest, most secure grip possible. Easy side access to the hoop clamp makes set up and tear down a breeze.



THE CONTROL CORE QUADBEATER
Provides four beater surfaces (two hard plastic, two felt) with the added feel of the vibration-free Control Core elastomer center. U.S. Patent #7626108



UNI-LOCK BEATER ANGLE CAM
Grips the axle a full 360 degrees, allowing infinite beater angle adjustments. Floating Spring Pendulum design is perfectly centered on the clamp for full bearing movement and maximum smoothness.

ELIMINATOR SOLO

ELIMINATOR SOLO : BLACK

Delivering blinding speed and powerful performance, Eliminator Solo bass drum pedals put the fleet footed player in control with all the gliding velocity that made Pearl pedals revolutionary. These no nonsense, streamlined Eliminator models deliver singular, resistance free feel for effortless play and driving performance.

The Solo: Black pedal's even, slightly weighted feel delivers just the right amount of resistance without slowing your stroke - for increased power and less muscle fatigue.

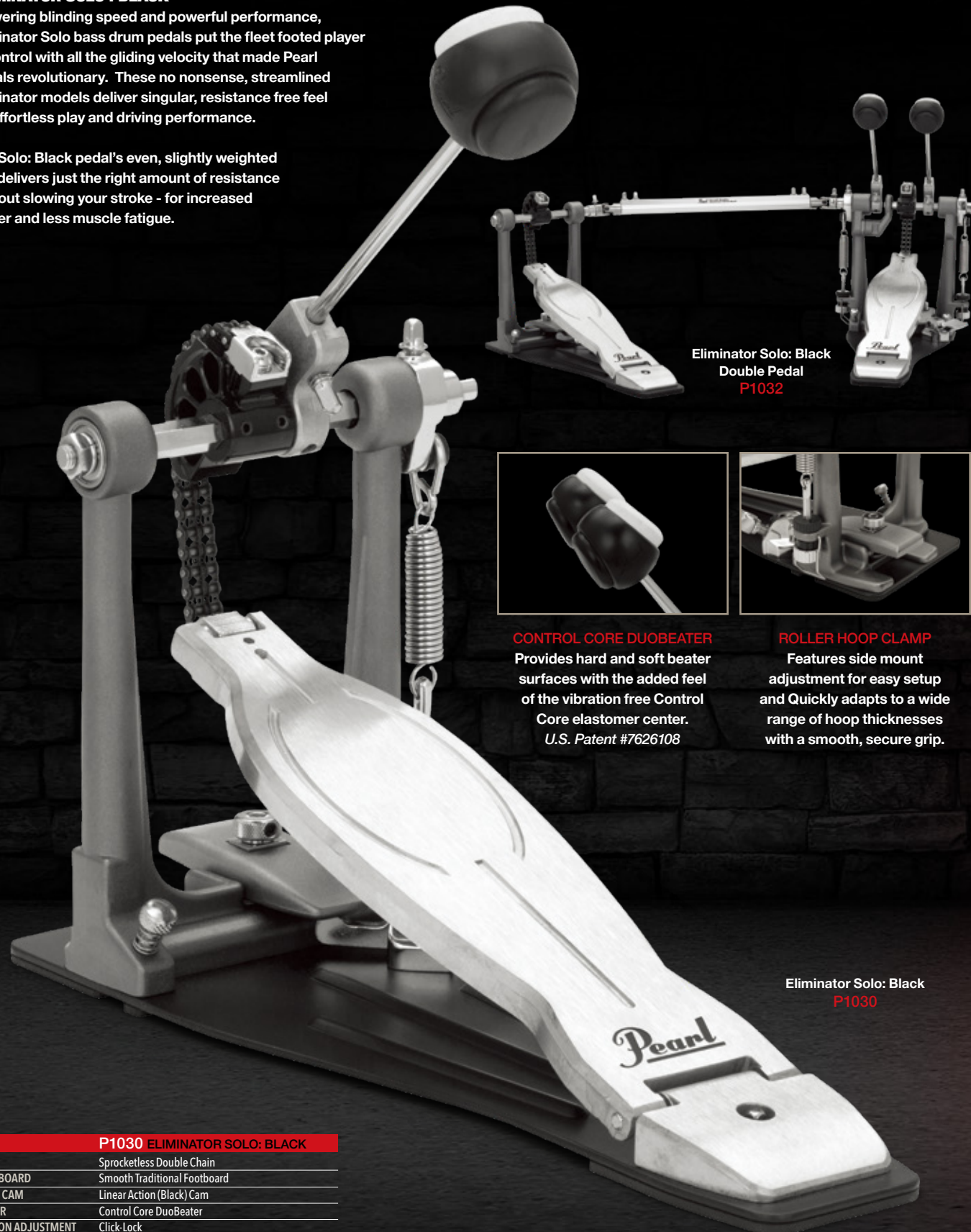

Eliminator Solo: Black Double Pedal P1032

Eliminator Solo: Black P1030



CONTROL CORE DUOBEATER
Provides hard and soft beater surfaces with the added feel of the vibration free Control Core elastomer center.
U.S. Patent #7626108

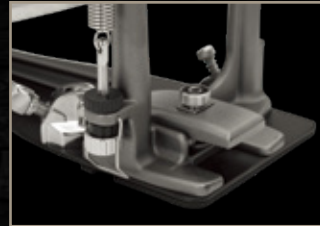

ROLLER HOOP CLAMP
Features side mount adjustment for easy setup and Quickly adapts to a wide range of hoop thicknesses with a smooth, secure grip.

| P1030 ELIMINATOR SOLO: BLACK | |
|------------------------------|------------------------------|
| Drive | Sprocketless Double Chain |
| FOOT BOARD | Smooth Traditional Footboard |
| DRIVE CAM | Linear Action (Black) Cam |
| BEATER | Control Core DuoBeater |
| TENSION ADJUSTMENT | Click-Lock |
| BEATER ANGLE | Uni-Lock Beater Angle Cam |
| POWERSHIFTER | Three Position |
| HOOP CLAMP | Roller Cam Hoop Clamp |

Singular Feel, Eliminator Speed, Priced to Perform. Fly Solo and Set Your Feet Free!

ELIMINATOR SOLO : RED

Delivering accurate speed and focused performance, the Eliminator Solo: Red bass drum pedal delivers no-nonsense Eliminator feel for the technically decisive player.

Focusing the drive on the accurate feel of the Radical Progressive Action of Eliminator: Redline Red Cam, its shape allows the double chain to better match the motion of your foot. This means smooth movement at the bottom of the stroke with an accelerated PUSH at the top, and quick rebound for reactive doubles.



Eliminator Solo: Red Double Pedal P1032R

Eliminator Solo: Red P1030R



CONTROL CORE QUADBEATER
Provides four beater surfaces (two hard plastic, two felt) with the added feel of the vibration-free Control Core elastomer center.
U.S. Patent #7626108



UNIVERSAL JOINT
All Eliminator Solo pedals come with Pearl's adjustable Universal Drive Joint, giving the secondary pedal the feel, power, and unrestrained feel of the main pedal.

| P1030R ELIMINATOR SOLO: RED | |
|-----------------------------|--------------------------------------|
| Drive | Sprocketless Double Chain |
| FOOT BOARD | Smooth Traditional Footboard |
| DRIVE CAM | Radical Progressive Action (Red) Cam |
| BEATER | Control Core Quad Beater |
| TENSION ADJUSTMENT | Click-Lock |
| BEATER ANGLE | Uni-Lock Beater Angle Cam |
| POWERSHIFTER | Three Position |
| HOOP CLAMP | Roller Cam Hoop Clamp |

P930 / P932 PEDALS

Speed and Control for the Masses

SUPER SMOOTH, EXTREMELY FAST!

Merging quick rebound response of our flagship Demon Drive with the finely-tuned control of our award-winning Eliminator models, the P930 bass drum pedal offers high end performance at a player accessible price. Its longboard playing deck delivers a lighter feel for increased speed, and offers advanced performance control and tunability with two rotor cam options. The ultimate pedal for fast feet on a budget.

| P930 BASS DRUM PEDAL | |
|----------------------|--|
| Drive | Single Chain Drive |
| FOOT BOARD | Demon Style Long Board |
| DRIVE CAM | Perfect Circle Cam w/ Removable Eliminator Style Progressive Cam |
| BEATER | Control Core DuoBeater |
| TENSION ADJUSTMENT | Click-Lock |
| BEATER ANGLE | Infinite Beater Angle Adjustment |
| POWERSHIFTER | 2 Position Powershifter Function |
| HOOP CLAMP | Adjustable Lever Clamp |
| UNIVERSAL JOINT | --- |

| | |
|--|-------|
| Single Pedal Complete | P930 |
| Double Pedal Complete (right footed) | P932 |
| Double Pedal Conversion Kit (right footed) | P931 |
| Double Pedal Complete (left footed) | P932L |



The P930 pedal is included as an upgrade in the 830 Series hardware pack and comes with Export drum sets.

Single Pedal Complete
P930

2 POSITION
POWERSHIFTER
FUNCTION

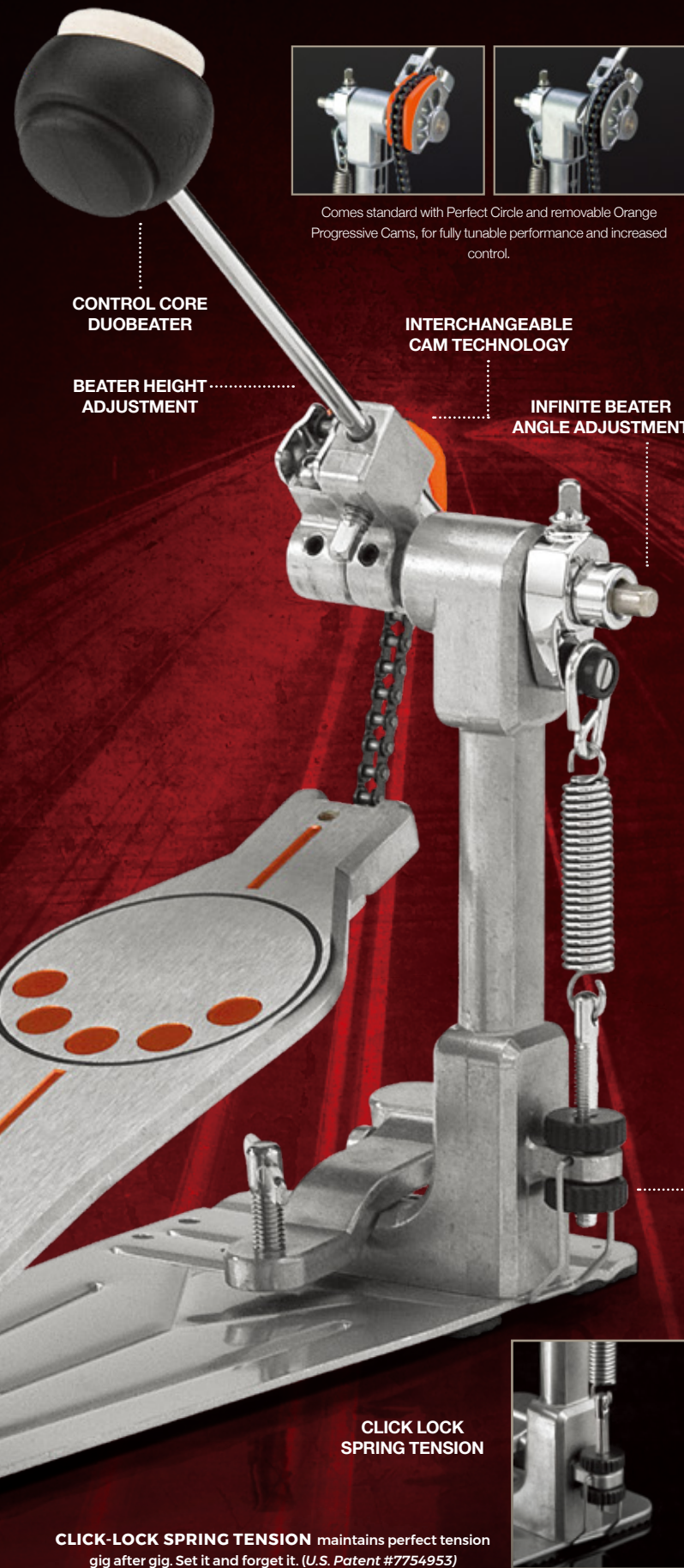

CLICK-LOCK SPRING TENSION maintains perfect tension gig after gig. Set it and forget it. (U.S. Patent #7754953)



Comes standard with Perfect Circle and removable Orange Progressive Cams, for fully tunable performance and increased control.



Double Pedal Complete
P932

P932 DOUBLE PEDAL COMPLETE
Double the speed, power and control with the P932 Double Pedal. Give your feet the gift of speed at a fraction of the cost of other "less innovative" pedals.

| P932 DOUBLE BASS DRUM PEDAL | |
|-----------------------------|--|
| Drive | Single Chain Drive |
| FOOT BOARD | Demon Style Long Board |
| DRIVE CAM | Perfect Circle Cam w/ Removable Eliminator Style Progressive Cam |
| BEATER | Control Core DuoBeater |
| TENSION ADJUSTMENT | Click-Lock |
| BEATER ANGLE | Infinite Beater Angle Adjustment |
| POWERSHIFTER | 2 Position Powershifter Function |
| HOOP CLAMP | Adjustable Lever Clamp |
| UNIVERSAL JOINT | Length and Position Adjustable |

ORANGE PROGRESSIVE CAM can be removed to reveal the Perfect Circle for further tunability to match your playing style.

CONTROL CORE DUO BEATER (U.S. Patent #7626108) utilizes an elastomer center to minimize vibration and features two unique playing surfaces (rounded felt and convex hard plastic surface) for quick-shifting tone and feel.

POWERSHIFTER FUNCTION (U.S. Patent #5574237) further tunes the power, feel, and leverage of the pedal by shifting the chain angle forward for lighter feel, or back for increased power.

Speed, Power, and Value

P530 / P830



| P530 | |
|--------------|--|
| Drive | Sprocketless Double Chain |
| FOOT BOARD | Standard Length |
| DRIVE CAM | Round/Linear Action |
| BEATER | DuoBeat Two-Surface (Hard Plastic/Felt.) |
| BEATER ANGLE | Uni-Lock Beater Angle Cam |

Single Pedal Complete
P530

P530 DRUM PEDAL

With all the speed and function of a pro bass drum pedal at half the price, Pearl's P530 Bass Drum Pedal features a dual chain and Linear Action cam drive for smooth, traditional pedal action and speed. The radius rod frame makes it highly portable for gigging, while features like a two surface DuoBeater and rotor tension axle clamp make it adaptable to virtually any feel or playing style.

| P830 | |
|--------------|----------------------------------|
| Drive | Single Chain |
| FOOT BOARD | Demon Style Longboard |
| DRIVE CAM | Perfect Circle |
| BEATER | DuoBeat Two-Surface |
| BEATER ANGLE | Infinite Beater Angle Adjustment |

Single Pedal Complete
P830

P830 DRUM PEDAL

Light in weight but not in features, the P830's Demon-style longboard increases playing surface for maximum leverage and speed. Its fully adjustable beater angle, Perfect Circle single chain cam, and DuoBeat two-surface beater deliver customizable feel for the player on the move.

HI-HAT STANDS

Biggest Advancement In Time-Keeping Since The Wristwatch

H2050

Sharing many of the key characteristics of Pearl's Eliminator Redline bass drum pedals, 2050 Series Hi-Hat Stands deliver unparalleled versatility and customization in hi-hat pedal control. The world's-only hi-hat stand featuring the Interchangeable Cam System, 2050 Series stands' customizable options are designed to eliminate resistance, reduce fatigue, and increase performance.

"Night in and night out, Pearl hardware keeps everything right where it should be, and without fail!"
- OKWA ANDREWS

BRIAN FRASIER-MOORE
Justin Timberlake / Pink

OKWA ANDREWS
Brian's Tech



CLA130
Closed Hi-Hat
Bass Drum Hoop Mounted
Side-to-Side,
Forward/Back Adjustable
Ultragrip Wingnut
Spring Adjustable
Cymbal Spread



CLH930
Closed Hi-Hat
Uni-Lock Tilter
Knurled Boom Arm
UltraGrip Wing Nuts
/ Wing Bolts



CLH70
Closed Hi-Hat
Multi-Angle Quickset Clamp
Gearless UniLock Tilter
Ultragrip Wingnut
Spring Adjustable Wash

The RH2050 Remote Hi-Hat's low-friction cable produces smooth, lag-free performance with the lightning-fast action of the PosiLink Twin Cam drive system. Fast, natural-feeling cymbal play is finally accessible virtually anywhere on the kit, or to facilitate multiple hi-hat system setups.

Pearl's Rapid Lock Super Grip's slip-proof clutch system features a patented 360° lock nut that provides vice-like clamping force for a super grip.

Features Eliminator Solo traditional footboard, double braced swiveling tripod, and gigging weight tubing for touring professionals.

Features Eliminator Solo traditional footboard, single braced swiveling tripod, and reduced weight for gigging professionals.

Features an independent tripod positioned separately from the pedal frame, making it the only flat based hi-hat stand specifically for double pedals.

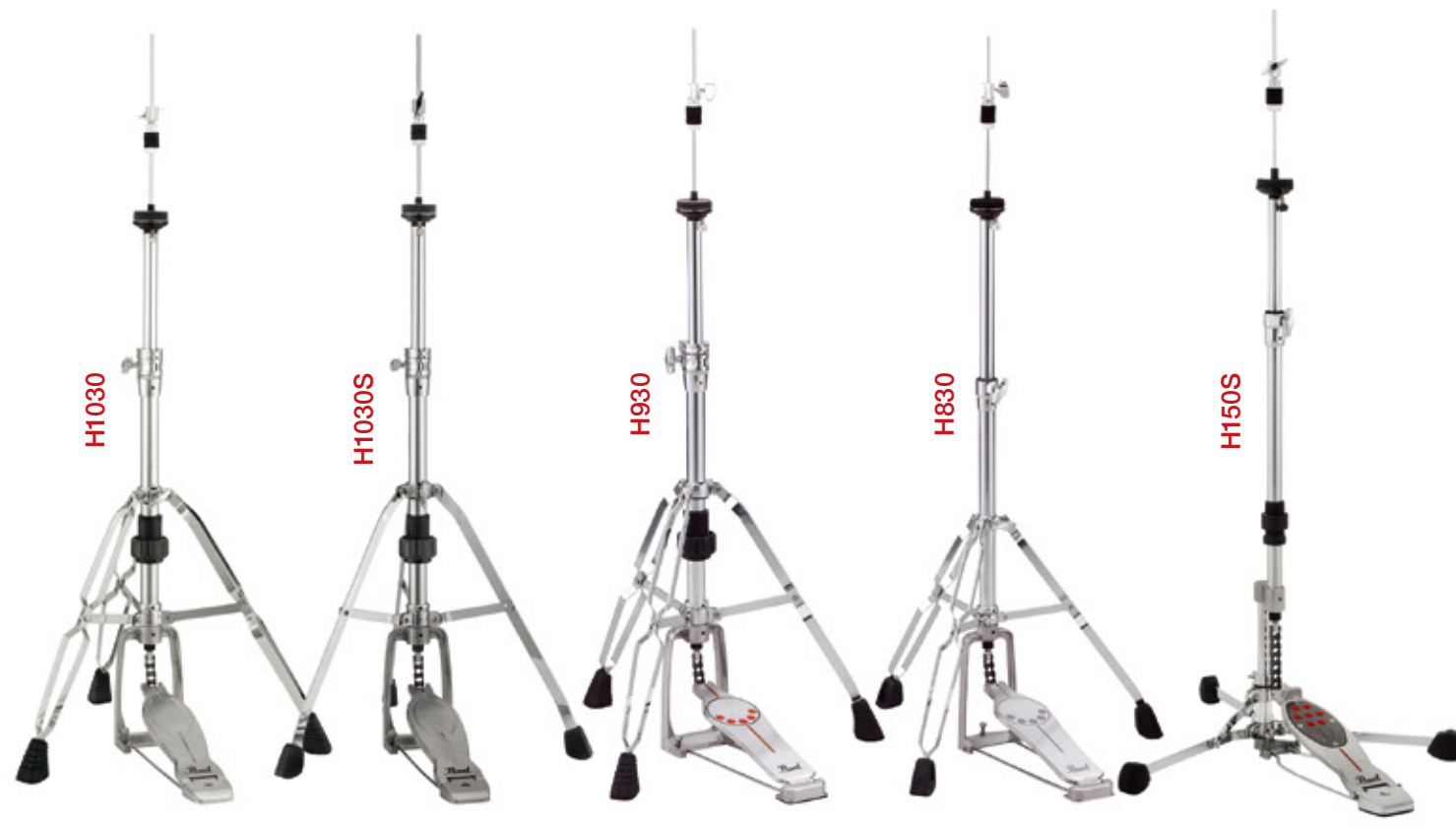
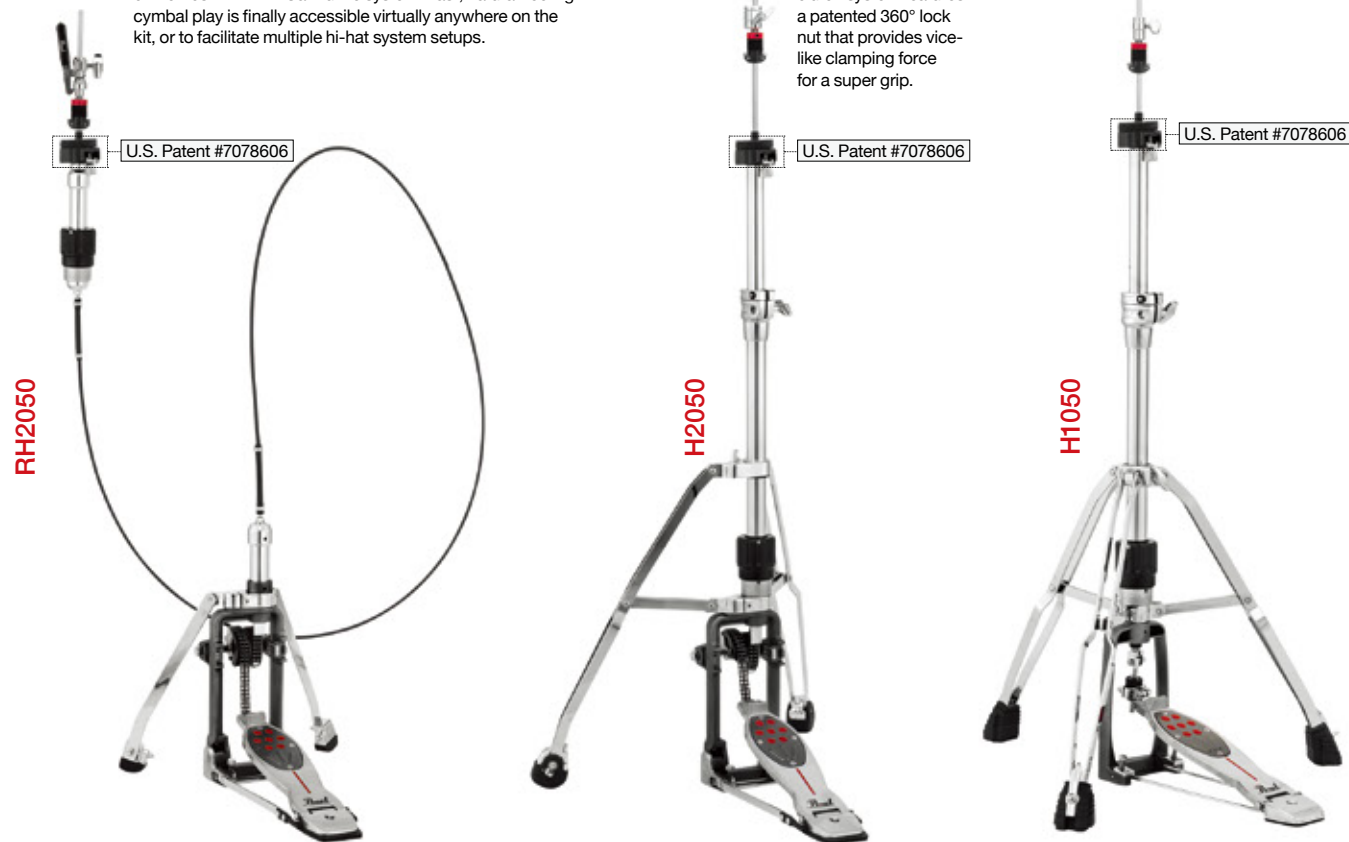

| | RH2050 | H2050 | H1050 |
|--------------------|--|--|--|
| Height Range | --- | 750 to 1030mm | 700 - 960mm |
| Drive | PosiLink Twin Cam Drive System with Interchangeable Cams | PosiLink Twin Cam Drive System with Interchangeable Cams | Direct Pull Drive System |
| Footboard | Redline Reversible Traction Plate | Redline Reversible Traction Plate | Redline Reversible Traction Plate |
| Clutch | Rapid Lock Clutch (U.S. Patent #9355625) | Rapid Lock Clutch (U.S. Patent #9355625) | Rapid Lock Clutch (U.S. Patent #9355625) |
| Tension adjustment | Precision Spring Tension Dial | Precision Spring Tension Dial | Precision Spring Tension Dial |
| Leg Function | Swiveling Legs | Swiveling Legs | Swiveling Legs |
| Leg Tip | Spike/Rubber Tips | Spike/Rubber Tips (U.S. Patent #7371953) | Spike/Rubber Tips |

| | H1030 | H1030S | H930 | H830 | H150S |
|--------------------|-------------------------------|-------------------------------|----------------------------------|----------------------------------|-----------------------------------|
| Height Range | 760 - 940mm | 760 - 940mm | 760 - 940mm | 610 - 910mm | 745 - 865mm |
| Drive | Direct Pull Drive System | Direct Pull Drive System | Direct Pull Drive System | Direct Pull Drive System | Direct Pull Drive System |
| Footboard | Smooth Traditional Footboard | Smooth Traditional Footboard | Demon Style Long Board Footboard | Demon Style Long Board Footboard | Redline Reversible Traction Plate |
| Clutch | Standard Clutch | Standard Clutch | Standard Clutch | Standard Clutch | Standard Clutch |
| Tension adjustment | Precision Spring Tension Dial | Precision Spring Tension Dial | Precision Spring Tension Dial | --- | Precision Spring Tension Dial |
| Leg Function | Swiveling Legs | Swiveling Legs | Swiveling Legs | Swiveling Legs | Swiveling Legs |
| Leg Tip | SureGrip Oversize Rubber Feet | --- | SureGrip Oversize Rubber Feet | --- | --- |



INDEPENDENT TRACTION GRIPS
Features Pearl's exclusive reversible Traction Plate and individual traction grips, configurable to suit your individual taste.



H2050 PRECISION SPRING TENSION DIAL
Allows perfect tension control for fine-tuned response.



H1050 PEDAL HEIGHT ADJUSTMENT
The infinite footboard angle adjustment featured on the H2050 and H1050 allows precise height matching in multi-pedal setups.



CLAMSHELL CLAMP
The H2050, H1050, H1030, H1030S, and H930 Hi-Hat Stand uses beefy 1" tubing and clamshell clamps with built in memory locks for superior rigidity.



HA130
Positions your hi-hat next to your bass pedal in double bass set-ups for effortless transitions between pedals.



H930 HI-HAT STAND
The H930 Hi-Hat Stand features our Demon style longboard, double braced tripod w/ swivel function, and precision tension dial.



H830 HI-HAT STAND
The H830 Hi-Hat Stand is standard equipment with our Export series and offers a monochromatic Demon Style longboard design and swivel tripod.



H150S* FLAT-BASED SWIVELING HI-HAT
The H150S independent tripod is positioned separately from the pedal frame making it the only flat-based hi-hat stand with swiveling legs.

SNARE STANDS

No matter the gig or the drum, Pearl has a stand to accommodate both with security, high function, and chameleon-like diversity.

Every Snare Should Be So Lucky



S1030



S1030D



S930

| | S1030 | S1030D | S930 |
|--------------|--|--|------------------------------------|
| Height Range | 480 - 700mm | 310 - 520mm | 470 - 670mm |
| Fit Snares | Adjustable Snare Basket: Fits Snares 10" - 16" | Adjustable Snare Basket: Fits Snares 10" - 16" | 10" - 14" |
| Tilter | GyroLock Tilter: Infinite Angle Adjustability | GyroLock Tilter: Infinite Angle Adjustability | Uni-Lock Tilter |
| Arm Tips | Air Suspension Rubber Tips | Air Suspension Rubber Tips | Air Suspension Rubber Tips |
| Tripod | Trident Tripod | Trident Tripod | Double Braced Trident Style Tripod |
| Leg Tips | Oversize Super Grip Rubber Feet | Oversize Super Grip Rubber Feet | Super Grip Rubber Feet |



S1030 SNARE STAND GYROLOCK
Our premier S1030 model features Pearl's 360 degree infinitely adjustable GyroLock tilter for ease-of-use and pinpoint positioning.



S1030 SNARE BASKET
The Pearl S1030 Snare Stand adjusts to fit virtually any size snare from 10" to 16". The Air Suspension rubber tips securely cradle your prized snares while allowing them to fully resonate.



S930D SNARE BASKET
The S930D Snare Stand is a shorter version of the S930 Snare Stand, and is built to comfortably accommodate deeper snare drums.

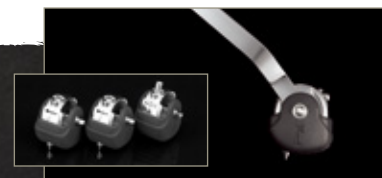

SPIKED / RUBBER FEET (Sold Separately)
Our CVT300/3 Push Button Spiked/Rubber Feet come in pack of 3 to retrofit on any of our 1030 Series hardware for sure-footed performance on any terrain. (U.S. Patent #7371953)



S930D



S930S



S830

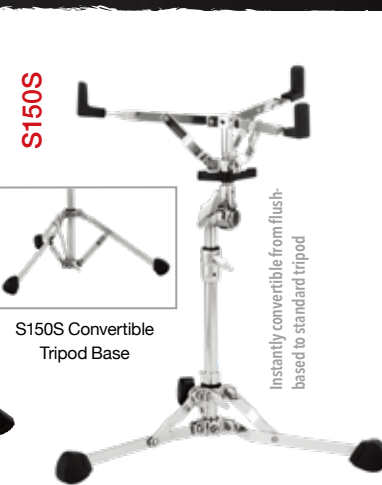

S150S

S150S Convertible Tripod Base

| | S930D | S930S | S830 | S150S |
|--------------|------------------------------------|------------------------------------|------------------------|--------------------------|
| Height Range | 360 - 570mm | 420 - 610mm | 440 - 650mm | 440 - 640mm |
| Fit Snares | 10" - 14" | 10" - 14" | 13" - 14" | 12" - 14" |
| Tilter | Uni-Lock Tilter | Uni-Lock Tilter | Uni-Lock Tilter | Uni-Lock Tilter |
| Arm Tips | Air Suspension Rubber Tips | Air Suspension Rubber Tips | Rubber Grip | Rubber Grip |
| Tripod | Double Braced Trident Style Tripod | Single Braced Trident Style Tripod | Double Braced Tripod | Stable Flat-Based Tripod |
| Leg Tips | Super Grip Rubber Feet | --- | Super Grip Rubber Feet | Convertible Rubber Feet |

DRUM THRONES

Sound Ergonomics

MULTI-CORE FOAM TECHNOLOGY: Roadster thrones now feature multiple layers of varied density foam which combine for a better playing foundation and improved feel.



D3500BR



D3500



D-1500TGL



D-1500RGL

| | D3500BR | D3500 | D-1500TGL | D-1500RGL |
|--------------|--|---------------------------------------|--|-----------------------------------|
| Height Range | 495-665mm | 495-665mm | 495-695mm | 495-695mm |
| Seat | Saddle-Style, Multi-Core Foam Cushion | Saddle-Style, Multi-Core Foam Cushion | 15" Trilateral Multi-Core Foam Cushion Option of a Saddle or Round top feel | 15" Round Multi-Core Foam Cushion |
| Legs | Double Braced Legs | Double Braced Legs | Lightweight Aluminum Struts | Lightweight Aluminum Struts |
| StopLock | Lock/Spin System: Reversible StopLock allows cushion to be secured in place or free spinning depending on preference | Lock/Spin Reversible StopLock System | Gas Lift | Gas Lift |
| Notes | Detachable Backrest Mounts via Single Knob | Accepts Optional Backrest | Accepts Optional Backrest | Accepts Optional Backrest |



D1500SP



D1500



D1500S



DTBR1535

| | D1500SP | D1500 | D1500S | DTBR1535 |
|--------------|--|--|--|--|
| Height Range | 525 - 630mm | 495 - 665mm | 445 - 615mm | 12.5" x 7" Optional Backrest |
| Seat | 15" Vented Round Seat Multi-Core Foam Donut Cushion | 15" Vented Round Seat Multi-Core Foam Donut Cushion | 15" Vented Round Seat Multi-Core Foam Donut Cushion | Formfitting and Breathable Removable Dual Axis Adjustability |
| Legs | Double Braced Legs | Double Braced Legs | Double Braced Legs | |
| StopLock | Lock/Spin Reversible StopLock System | Lock/Spin Reversible StopLock System | Lock/Spin Reversible StopLock System | |
| Notes | Accepts Optional Backrest Built-In Shock Absorber Post w/ Adjustable Spring Tension | Accepts Optional Backrest | Accepts Optional Backrest | |



D930



D790



D730S



D50

| | D930 | D790 | D730S | D50 |
|--------------|---------------------|---------------------|----------------------|----------------------|
| Height Range | 470 - 660mm | 430 - 650mm | 405 - 605mm | 495 - 620mm |
| Seat | Round Vinyl Cushion | Round Vinyl Cushion | Round Vinyl Cushion | Round Vinyl Cushion |
| Legs | Double Braced Legs | Double Braced Legs | Single Braced Tripod | Double Braced Tripod |

CYMBAL STANDS

Welcome to Boom Town

FOR EVERY CYMBAL, THERE IS A PLACE.

Advancing Drum Hardware for Serious Working Drummers since 1946. Through constant setup, teardown, performance, practice, and transport, Pearl has you covered with cymbal stand solutions that are ready to endure constant abuse and keep going.

Pearl hardware is literally the only hardware that you'll ever have to buy and it's all backed by their incredible lifetime warranty!

- TRACY BROUSSARD -

The most technically advanced boom stand ever devised. Perfect for studio or live applications.



| | BC2030 | BC1030C | BC1030 | BC930 |
|------------------------|-------------------------------------|-------------------------------------|-------------------------------------|--|
| Type | Boom | Curved Boom | Boom | Boom/Straight |
| Height Range | 800 - 2150mm | 820 - 1900mm | 820 - 1900mm | 830 - 1800mm |
| Nut | WingLoc | WingLoc | WingLoc | Plastic Wingnut |
| Washer | Reversible Form / Felt Washer | Reversible Form / Felt Washer | Reversible Form / Felt Washer | Felt Washer |
| Cymbal Cup | Reversible Cup Washer w/ O-ring | Reversible Cup Washer w/ O-ring | Reversible Cup Washer w/ O-ring | Plastic Cymbal Cup |
| Tilter | GyroLock Tilter | GyroLock Tilter | GyroLock Tilter | Uni-Lock Tilter |
| Pipe Joint | Clamshell Clamp | Clamshell Clamp | Clamshell Clamp | Clamshell Clamp |
| Legs(Tripod) | Trident Tripod / Double Braced Legs | Trident Tripod / Double Braced Legs | Trident Tripod / Double Braced Legs | Trident Style Tripod / Double Braced Leg |
| Pipe diameter of stand | 28.6/22.2/15.9mm | 28.6/22.2/15.9mm | 28.6/22.2/15.9mm | 28.6/22.2/15.9mm |

Reduced weight for easy gigging transport.

Offers lighter weight with advanced appointment designs.

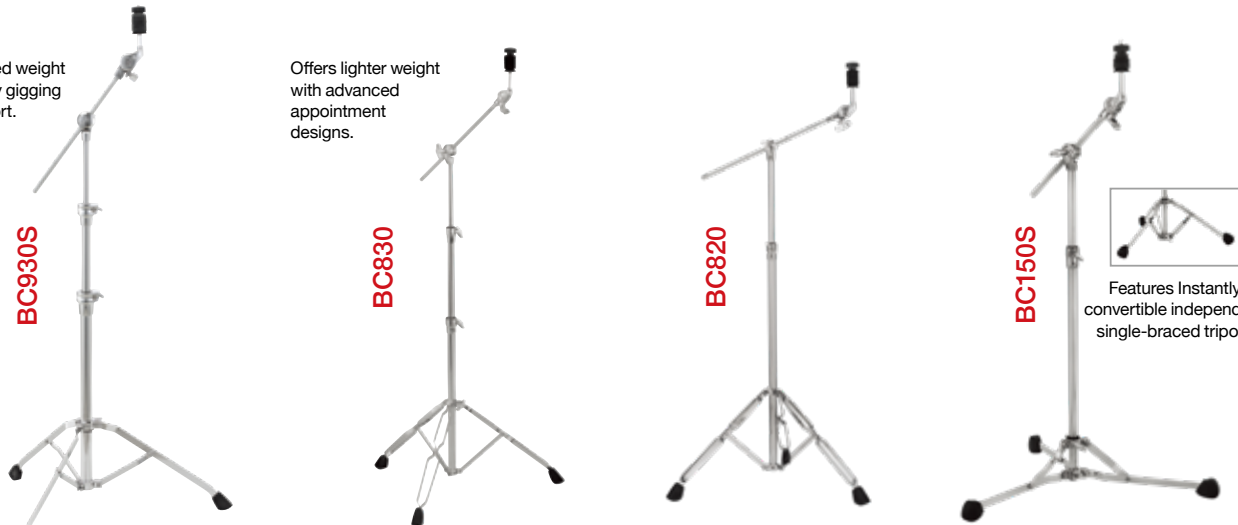

| | BC930S | BC830 | BC820 | BC150S |
|------------------------|---|---|---|---|
| Type | Boom/Straight | Boom/Straight | Boom/Straight | Boom/Straight |
| Height Range | 780 - 1800mm | 780 - 1480mm | 900 - 1740mm | 780 - 1300mm |
| Nut | Plastic Wingnut | Plastic Wingnut | Plastic Wingnut | Plastic Wingnut |
| Washer | Felt Washer | Felt Washer | Felt Washer | Reversible Felt/Foam Washer |
| Cymbal Cup | Plastic Cymbal Cup | Plastic Cymbal Cup | Plastic Cymbal Cup | Plastic Cymbal Cup |
| Tilter | Uni-Lock Tilter / Convertible Boom Tilter | Uni-Lock Tilter / Convertible Boom Tilter | Uni-Lock Tilter / Convertible Boom Tilter | Uni-Lock Tilter / Convertible Boom Tilter |
| Pipe Joint | Clamshell Clamp | Nylon Bushing Joint | Nylon Bushing Joint | Nylon Bushing Joint |
| Legs(Tripod) | Trident Style Single Braced Legs | Double Braced Legs | Double Braced Legs | Single Braced Tripod |
| Pipe diameter of stand | 28.6/22.2/15.9mm | 25.4/22.2/15.9mm | 22.2mm/15.9mm | 19.1 / 15.9 mm |

Solid. Stable. Professional.

Exceptional stability for gigging and touring.

Built for rigid support and light transport.

Offers lighter weight with advanced appointment designs.

Features Instantly convertible independent single-braced tripod.



| | C1030 | C930 | C930S | C830 | C150S |
|------------------------|-------------------------------------|--------------------|--------------------|---------------------|-----------------------------|
| Type | Straight | Straight | Straight | Straight | Straight |
| Height Range | 770 - 1530mm | 760 - 1500mm | 780 - 1480mm | 720 - 1480mm | 670 - 1350mm |
| Nut | WingLoc | Plastic Wingnut | Plastic Wingnut | Plastic Wingnut | Plastic Wingnut |
| Washer | Reversible Form / Felt Washer | Felt Washer | Felt Washer | Felt Washer | Reversible Felt/Foam Washer |
| Cymbal Cup | Reversible Cup Washer w/ O-ring | Plastic Cymbal Cup | Plastic Cymbal Cup | Plastic Cymbal Cup | Plastic Cymbal Cup |
| Tilter | GyroLock Tilter | Uni-Lock Tilter | Uni-Lock Tilter | Uni-Lock Tilter | Uni-Lock Tilter |
| Pipe Joint | Clamshell Clamp | Clamshell Clamp | Clamshell Clamp | Nylon Bushing Joint | Nylon Bushing Joint |
| Legs(Tripod) | Trident Tripod / Double Braced Legs | Trident Style | Trident Style | Double Braced Legs | Single Braced Tripod |
| Pipe diameter of stand | 28.6/22.2/15.9mm | 28.6/22.2/15.9mm | 28.6/22.2/15.9mm | 25.4/22.2/15.9mm | 19.1 / 15.9 / 12.7mm |



Boomerang Curved Boom Arm with Clamp and Tilter
CHC200



Boomerang Curved Cymbal Boom Arm
CHC100



Boom Arm Cymbal Holder
CH70



Mic Holder
MH70A



Two Way Arm Clamp
DCA180



Arm & Leg Cymbal Adapter (shown w/ DC180)
CHA70

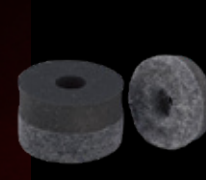

REVERSIBLE FELT / FOAM CYMBAL WASHERS allow four-way control of cymbal "ring" by mixing and matching the "hard" and "soft" surfaces of the washers.

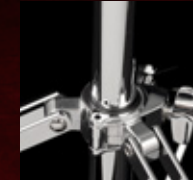

THE TRIDENT TRIPOD uses a full 360° of clamping force via the hinged collar. The inner tube rests in a nylon bushing to prevent metal to metal contact. Heavy duty legs feature lateral bracing for superior ultra quiet rigidity.



REVERSIBLE CUP WASHER w/ O-RING (U.S. Patent #6940006) Specially designed to "float" normally or "lock" to prevent noise during recording.

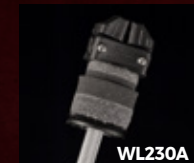

WINGLOC

Quick Release Wing Nut (U.S. Patent #6884015) Secure, adjustable, spring loaded cymbal nuts for quick set up and tear down.



NODAL POINT MARKINGS Pearl's BC2030 features markings on the telescopic tubes that allow cymbals to achieve better clarity and sustain when the tubes are positioned at their respective Nodal Points. (U.S. Patent #9070348)



GYROLOCK TILTERS are infinitely adjustable and provide 360 degree range of motion for precise positioning with one-step convenience.

ICON RACK SYSTEM

The Original Drum Rack, Expanded



RACKS Preconfigured single and three-sided rack packages with rotating support feet.



MASTERWORKS SERIES STUDIO SHELL RECIPE
in Gloss Natural Artisan Sycamore with Ebony inlay & Black Nickel Hardware

MASTERWORKS SERIES with ICON RACK & e/MERGE
in Black Sparkle Burst to Granite Sparkle & Black Nickel Hardware



3-Sided Rack
(*also available DR008 Expansion Bar)
DR80

Developed in 1983 with legendary Toto drummer Jeff Porcaro, Pearl's original DR1 Drum Rack was the first freestanding, frame based drum support system available.

Now, Pearl expands the **ICON** (short for Independent **CON**trol) Rack system with a fresh selection of upgrades and high function mounting options.

| DR80 | |
|--------------------|------------------------------------|
| SUMMARY | 3-Sided Rack |
| RAILS | Black Painted Steel 38.1mm x 910mm |
| PIPES | Black Painted Steel 38.1mm x 705mm |
| RAIL CLAMPS | PC-8 (x4) |



Three-Sided Drum Rack, Straight
(w/ PCX100X4 & PCL100X2)
DR513

| DR513 | |
|-------------------------|--|
| SUMMARY | Three-Sided Drum Rack, Straight |
| RAILS | Aluminum, 40mm Square |
| PIPES | Steel 38.1mm x 865mm |
| RAIL CLAMPS | PCX100 (x4) |
| PIPE CLAMPS | PCL100 (x2) |
| SUPPORT FOOT | 38.1mm x 475mm (P38475TA x4) |
| USABLE RAIL AREA | 915mm (965mm From Center of Right to Left Clamp) |



Three-Sided Drum Rack, Curved
(w/ PCX100X4 & PCL100X2)
DR513C

| DR513C | |
|-------------------------|--|
| SUMMARY | Three-Sided Drum Rack, Curved |
| RAILS | Aluminum, 40mm Square |
| PIPES | Steel 38.1mm x 865mm |
| RAIL CLAMPS | PCX100 (x4) |
| PIPE CLAMPS | PCL100 (x2) |
| SUPPORT FOOT | 38.1mm x 475mm (P38475TA x4) |
| USABLE RAIL AREA | 915mm (965mm From Center of Right to Left Clamp) |



Single Drum Rack, Straight
(w/ PCX100X2 & PCL100X2)
DR511

| DR511 | |
|-------------------------|--|
| SUMMARY | Single Drum Rack, Straight |
| RAILS | Anodized Aluminum Square Bar 40mm x 915mm |
| PIPES | Steel 38.1mm x 865mm |
| RAIL CLAMPS | PCX100 (x2) |
| PIPE CLAMPS | PCL100 (x2) |
| SUPPORT FOOT | 38.1mm x 475mm (P38475TA x2) |
| USABLE RAIL AREA | 915mm (965mm From Center of Right to Left Clamp) |



Single Drum Rack, Curved
(w/ PCX100X2 & PCL100X2)
DR511C

| DR511C | |
|-------------------------|--|
| SUMMARY | Single Drum Rack, Curved |
| RAILS | Anodized Aluminum Square Bar 40mm x 915mm |
| PIPES | Steel 38.1mm x 865mm |
| RAIL CLAMPS | PCX100 (x2) |
| PIPE CLAMPS | PCL100 (x2) |
| SUPPORT FOOT | 38.1mm x 475mm (P38475TA x2) |
| USABLE RAIL AREA | 1118mm (1168mm From Center of Right to Left Clamp) |



Straight Drum Rack Expansion Bar w/ Support Leg
DR511E

| DR511E | |
|-------------------------|--|
| SUMMARY | Straight Drum Rack Expansion Bar w/ Support Leg |
| RAILS | Anodized Aluminum Square Bar 40mm x 915mm |
| PIPES | Steel 38.1mm x 865mm |
| SUPPORT FOOT | 38.1mm x 475mm (P38475TA x1) |
| USABLE RAIL AREA | 915mm (965mm From Center of Right to Left Clamp) |



Curved Drum Rack Expansion Bar w/ Support Leg
DR511CE

| DR511CE | |
|-------------------------|--|
| SUMMARY | Curved Drum Rack Expansion Bar w/ Support Leg |
| RAILS | Anodized Aluminum Square Bar 40mm x 915mm |
| PIPES | Steel 38.1mm x 865mm |
| SUPPORT FOOT | 38.1mm x 475mm (P38475TA x1) |
| USABLE RAIL AREA | 1118mm (1168mm From Center of Right to Left Clamp) |



Drum Rack Moveable w/Support T-Leg
DR110T

| DR110T | |
|-------------------------|--|
| SUMMARY | Drum Rack Moveable Support T-Leg |
| RAILS | --- |
| PIPES | --- |
| SUPPORT FOOT | 965mm x 64mm Round Chrome w/ P38475TA x1 |
| USABLE RAIL AREA | --- |

RACK ACCESSORIES

An Industry Icon - The Professional's Choice

ICON RACK RECIPES

Check out Pearl's ICON Rack Recipe videos at www.pearlrackrecipes.com for step-by-step instructions on how to get the most from existing and available Pearl Rack parts.

MOUNTING CLAMPS

Developed for the slip resistant ICON square rack rail and round support pipe. Each dramatically increases the level of setup flexibility and function variety.



Expandable Pipe Clamp
Fits All Icon Rack Leg Posts
PCL100

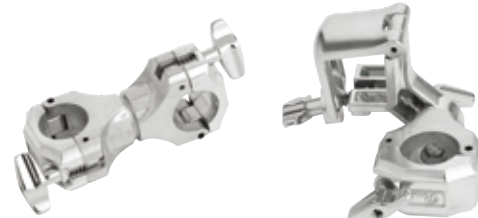

Dual Pipe Clamp
PCR100

Pipe To Rail Clamp
PCR200



Pipe To Rail Clamp
PCR200L



Rotating Pipe Accessory Clamp
PCR50X



Pipe Accessory Clamp
PCR50L



Rotating Dual Pipe Clamp
PCR50R



Curved Rack Rail Short w/ Clamp
AL86AC



Curved Rack Rail Medium w/ End Caps
AL103A



Icon Support Foot w/ TLJ200 T-Clamp
P38475TA



Icon Rail Accessory Clamp w/ Adjustable Jaw
PCX100



Icon Rotating Pipe Clamp w/ Adjustable Jaw
PCX200



Extended Rotating Rail Accessory Clamp
PCX300



Pipe Clamp
Fits 7/8" tubes, for DR80
PC8



6" Mini-Expansion Bar
RJ50



Pipe Joint
RJ100



ADP20



2 Clamps
Fits 5/8" to 1-1/8"
ADP20



AX25



2 Revolving Clamps
Fits 1/2" to 1-1/8"
AX25



AX25L



2 Revolving Clamps
Fits 1/2" to 1-1/8"
AX25L



AX28



In-Line & Revolving Clamps
Fits 5/8" to 1-1/8" & 1/2" to 1-1/4"
AX28



ADP30



3 Adjustable Clamps
Fits 3/8" to 1-1/4"
ADP30

TOM STANDS / ARMS

Positioning Possibilities Never Before Attainable



T1035

T1035L

T935

TC1035B

TC1035BL

TC935



CHB75CA

CHB75LB

CH1030B

CH930

CH830

MH830
Mic Holder

CH1030BS

CH930S

CH830S



TH1030

TH1030S

TH1030I

THL1030
U.S. Patent Pending

THL1030S
U.S. Patent Pending

TH900S

TH900I

TH88S

TH88I

TH70S

TH70I

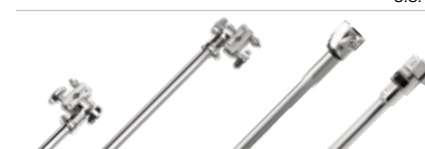

UX80S **UX80**

Features rotating infinitely adjustable clamps for multiple uses.

Tube Height Extender
TX100

Accepts 7/8" dia. tubes. Ideal for extending snare stand height.

Tube Extender for 1" Pipe
TX125

Accepts 1" dia. tubes. Ideal for extending travel conga stands.



Chrome Multi Bass Drum Legs
PMBDL3/C

Multi-Bass Drum Legs allow any bass drum to be played horizontally. Height and tilt adjustable.

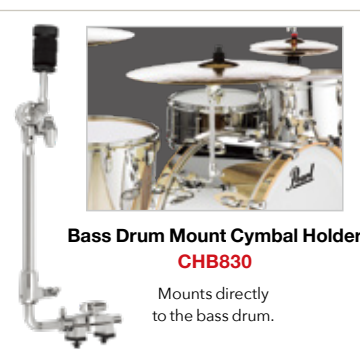

Bass Drum Mount Cymbal Holder
CHB830

Mounts directly to the bass drum.

PEARL PERCUSSION ARTISTS

VIEW ALL THE PEARL ARTISTS AT:



AARON DRAPER
John Mayer / Eminem / Adele

ALAIN PEREZ
Alain Perez

ANDY FARAG
Umphreys McGee

ARCHIE PENA
Shakira

BOBBY ALLENDE
Tito Nieves

BRETT BAKER
Rihanna / Jay-Z



CAMILO QUINONES
El Dusty

CARLITO SOTO
Willie Colon

CARLITOS PADRON
Rumberos Del Callejon

CESAR ESPINOZA
Orchestra Tobaco Y Ron

CHRISTIAN PEPIN
Independent

COLIN DOUGLAS
Aerosmith



CRYSTAL VARGAS
Independent

DIMAS SANCHEZ
Fusion Beat / Trilogy Latin Jazz

DOMINIQUE THOMAS
John Legend / Jill Scott

EMRAH KOTAN
Independent

ETTIENNE FUENTES
Independent

HORACIO HERNANDEZ
Independent



JESSIE CARABALLO
Marc Anthony

JESUS DIAZ
Independent

JOSE ROSA
Independent

LALO DAVILA
MTSU

MARC QUIÑONES
The Doobie Brothers

MARCO "ITO" ARGUINZONI
Independent



MARVIN DIZ
Independent

OG
Slightly Stoopid

OMAR LEDEZMA
Independent

PAPO PEPIN
N.Y. Conga Legend

RAFA PEREIRA
Janelle Monae

RAVI JAKHOTIA
Ravi Drum



ROLANDO MORALES MATOS
The Lion King / Curtis Institute

SAMMY FIGUEROA
Master Percussionist

TRILOK GURTU
Independent

VALERIE DEE NARANJO
The Lion King / Saturday Night Live

ZIG WAJLER
Hands-On With Zig

SIGNATURE SERIES

The Pros Play Pearl!

BOBBY ALLENDE

Bobby Allende is a mainstay in the New York Latin Music Scene and he demands the best from his drums, that's why he plays Pearl. His Signature drums are fiberglass with no seams to inhibit vibration which allow the drums to resonate freely for the full, rich sound that Bobby is famous for. The congas are 28 inches tall, fitting the traditional seated player perfectly while adding extra width to the base for added projection and stability. A matching set of bongos is also available.



#617 Confetti
Signature Fiberglass
Congas and Bongos



- SHELL** Seamless Fiberglass
- HEADS** Remo Fiberskyn3
- RIMS** Low-Rider Contour Crown
- HARDWARE** Brushed Steel
- FINISH** #617 Confetti
- BONGOS** PBF300DXBA
- OPTIONAL BAGS** PSC110CG 11" Quinto Conga Bag
PSC117CGW 11.75" Conga Bag
PSC125CG 12.5" Tumba Conga Bag

The Bobby Allende congas and bongos feature Remo Fiberskyn 3 heads for tuning stability and Pearl's Low-Rider crowns with a radical sloping edge that practically disappears under your hands for comfort you have to experience to believe.

If you demand excellence like Bobby, check out his Signature Fiberglass Congas and Bongos.

- CONGAS**
- PCF110DXBA617** 11" QUINTO
- PCF117DXBA617** 11.75" CONGA
- PCF125DXBA617** 12.5" TUMBA

- BONGOS**
- PBF300DXBA617** 7" & 8.5"

JESUS DIAZ

Cuban born Jesus Diaz is one of the most in demand percussionists and vocalists on the scene today. His active schedule provided the feature set for his signature series of congas and bongos. Designed for the seated player the Thai Oak drums measure 30" tall and from the Quinto to Tumba feature added girth to the belly of the drum. Seated conga players typically have to tilt the drum to achieve the desired projection, but the Jesus Diaz drums feature a 4" port on the front of the drum that is strategically positioned to deliver the maximum base frequency while the drum remains flat on the floor.



PHOTO: LISA KEATIN



- SHELL** Thai Oak
- HEADS** Buffalo Skin
- RIMS** Low-Rider Contour Crown
- HARDWARE** Quick Release Lugs
Brushed Steel Finish
- FINISH** #580 Brushed Platinum
- BONGOS** PBW300DXJD
- OPTIONAL BAGS** PSC110CG 11" Quinto Conga Bag
PSC117CGW 11.75" Conga Bag
PSC125CG 12.5" Tumba Conga Bag



#580 Brushed Platinum
Natural Buffalo Skin Heads

The drums also feature a newly designed Quick Release lug that is slotted to allow removal of the tension rod without fully removing the nut. Player comfort was also an important ingredient in the design of the hoop. A new ergonomically friendly design reduces the impact to your hands while an internal ring centers the natural buffalo skin heads for accurate placement.

- CONGAS**
- PCW110DXPJD580** 11" QUINTO
- PCW117DXPJD580** 11.75" CONGA
- PCW125DXPJD580** 12.5" TUMBA

- BONGOS**
- PBW300DXJD580** 7" & 8.5"

CONGAS & BONGOS

Tools of the Trade

ELITE SERIES

ELITE WOOD-FIBER CONGAS

PWFC110DX648 - 11" QUINTO
PWFC117DX648 - 11.75" CONGA
PWFC125DX648 - 12.5" TUMBA

SHELL Blended, Thai Oak over Fiberglass
 HEADS Natural Cow Skin
 RIMS Contour Crown
 HARDWARE Brushed Steel
 FINISH #648 Maduro Brown

ELITE WOOD-FIBER BONGOS

PWFB100DX648 - 7" & 8.5"



ELITE OAK CONGAS

PCW110DX510 - 11" QUINTO
PCW117DX510 - 11.75" CONGA
PCW125DX510 - 12.5" TUMBA

SHELL 100% Thai Oak
 HEADS Premium Natural Cow Skin
 RIMS Contour Crown
 HARDWARE Brushed Steel
 FINISH #510 Caramel Brown

ELITE OAK BONGOS

PBW300DX510 - 7" & 9"



ELITE FIBERGLASS CONGAS

PCF110DXA - 11" QUINTO
PCF117DXA - 11.75" CONGA
PCF125DXA - 12.5" TUMBA

SHELL Fiberglass
 HEADS Premium Natural Cow Hide
 RIMS Contour Crown
 HARDWARE Brushed Steel
 FINISH #641 Blue Sparkle Burst

ELITE OAK BONGOS

PBF300DXA - 7" & 9"

ELITE OAK CONGAS

PCW110DX504 - 11" QUINTO
PCW117DX504 - 11.75" CONGA
PCW125DX504 - 12.5" TUMBA

SHELL 100% Thai Oak
 HEADS Premium Natural Cow Skin
 RIMS Contour Crown
 HARDWARE Chrome
 FINISH #504 Mocha Burst

ELITE OAK BONGOS

PBW300DX504 - 7" & 9"



ELITE OAK CONGAS

PCW110DX506 - 11" QUINTO
PCW117DX506 - 11.75" CONGA
PCW125DX506 - 12.5" TUMBA

SHELL 100% Thai Oak
 HEADS Premium Natural Cow Skin
 RIMS Contour Crown
 HARDWARE Chrome
 FINISH #506 Merlot Burst

ELITE OAK BONGOS

PBW300DX506 - 7" & 9"



Also available in #532 Cherry Eucalyptus

ELITE OAK CONGAS

PCW110DXG - 11" QUINTO
PCW117DXG - 11.75" CONGA
PCW125DXG - 12.5" TUMBA

SHELL 100% Thai Oak
 HEADS Premium Natural Cow Skin
 RIMS Contour Crown
 HARDWARE Gold
 FINISH #535 Satin Black

ELITE OAK BONGOS

PBW300DXG - 7" & 9"

HAVANA SERIES

HAVANA CONGAS

PCF110HV - 11" QUINTO **PCF117HV** - 11.75" CONGA

PCF125HV - 12.5" TUMBA

HAVANA BONGOS

PBF300HV - 7" & 8.5"



The wide belly shape of these high end, fiberglass drums produce deeper low tones and greater volume.

SHELL Fiberglass
 HEADS Natural Cow Skin
 RIMS Contour Crown
 HARDWARE Chrome
 FINISH #644 Liquid Gold

SHELL Fiberglass
 HEADS Natural Cow Skin
 RIMS Contour Crown
 HARDWARE Chrome
 FINISH #187 Silver White Swirl

SHELL Fiberglass
 HEADS Natural Cow Skin
 RIMS Contour Crown
 HARDWARE Chrome
 FINISH #651 Red Tiger Stripe

PRIMERO PRO

PRIMERO PRO FIBERGLASS



11.75" & 12.5" Conga Set #628 Blue Marble
 Shown with matching bongos
PFC302DX628



10" & 11" Conga Set
 #621 Wine Red Marble
PFC202DX621



7" & 8.5" Bongos
 #523 Carbon Vapor
PWB100DX523

11.75" & 12.5" Congas
 #523 Carbon Vapor
PWC302DX523

PFC302DX628 #626 Gold Marble



Designed with professional features at an affordable price. Our expanded range of sizes offers 10" & 11" and 11.75" & 12.5" sets in both Thai Oak and Fiberglass with matching bongos.

PRIMERO PRO FIBERGLASS

PFC302DX (11.75" & 12.5" Conga Set)
PFC202DX (10" & 11" Conga set)

Offer added durability of fiberglass and are louder drums with a crisper sound than wood.

SHELL Fiberglass
 HEADS Buffalo Skin
 RIMS Contour Crown
 HARDWARE Brushed Steel
 FINISH #621 Wine Red Marble
 #626 Gold Marble
 #628 Blue Marble

PRIMERO PRO OAK

PWC302DX (11.75" & 12.5" Conga Set)
PWC202DX (10" & 11" Conga set)

Primero Pro wood congas are made with Thai Oak and produce a warm, rich tone.

SHELL Thai Oak
 HEADS Buffalo Skin
 RIMS Contour Crown
 HARDWARE Brushed Steel
 FINISH #511 Natural
 #521 Midnight Fade
 #523 Carbon Vapor

PRIMERO



10" & 11" Conga Set w/ PC300 Stand
PFC203602

Primero Series congas and bongos are available with fiberglass shells and in packages that include a double stand (PC300W) or without stands.



10" & 11" Conga Set
PFC202602

SHELL Fiberglass
 HEADS Buffalo Skin
 RIMS Contour Crown
 HARDWARE Black Powder Coat
 FINISH #602 Bistre Black

FIELD PERCUSSION



Weather resistant fiberglass body that delivers a thunderous low-end tone. Remo Nuskyn heads.

10" & 11" Congas
 #649 Textured Black
PFC202EDU649

CONGA RESO-PLATE



Designed for the seated conga player, Pearl's Reso-Plate will give you that hard surface desired for maximum resonance. Configured with a cutout handle, the plates can also easily be placed on top of your drums for extra protection when packed in your conga case.

Conga Reso-Plates
PRP140

TRAVEL

Congas, Bongos, & Timbales



Where can you take the Pearl Travel Congas and Bongos? The answer is anywhere you can take traditional drums but without any of the hassle. The Travel Congas feature a 3.5" deep wood shell with stave construction and Remo Symmetry heads. Available in three sizes: 11" x 3.5", 11.75" x 3.5" and 12.5" x 3.5" each with five precision Allen bolts. The 7" and 8.5" Travel Bongos feature 3.5" Thai Oak shells with Remo Fiberskyn heads and three point tuning. The Travel Congas and Bongos include a foam-handle tuning wrench.

CONGAS



11.75" Travel Conga
#510 Caramel Brown
PTC1175N510

12.5" Travel Conga
#510 Caramel Brown
PTC1250N510

11" Travel Conga
#510 Caramel Brown
PTC1100N510



Travel Conga Bag
PSC1175TC



Travel Bongos Bag
PSC785TB

The optional Travel Conga Stand works with all three size drums and features a tension lever mounting system that locks the drum into place. The wide based, double braced legs provide a solid foundation for your drum and prevents the stand from moving during performance.

BONGOS



Travel Bongos
#510 Caramel Brown
PTB785



Travel Conga Stand w/ Carrying Bag
PC800TC

Travel Bongos Stand
PC800TB
PC800TBS (Short)



TIMBALES



Travel Timbales 14" & 15" with Stand*
PTTM1415

*Bag sold separately



The Pearl Travel Timbales feature 14" and 15" steel shells that are professional size in diameter but only 4" deep.



The drums are connected by a hinge that marries them to the Quick Release stand. The custom hinge allows the drums to be folded together into the size of one standard depth timbale for easy storage and transportation.



The Travel Timbales come with a single braced stand that includes an 11.25" adjustable accessory post with 6 positions that allow cowbells and blocks to be placed the perfect distance from the player.



The steel shells feature a black lacquer finish and USA Remo clear Ambassadors heads for a truly professional sounding instrument. A soft carrying case for the stand is also included (sold separately).

TIMBALES

MARC QUIÑONES
Doobie Brothers



MARC QUIÑONES SIGNATURE TIMBALES



Marc Quiñones Signature Timbales
14"x7" / 15"x7" Steel w/ PT900 Tilting Stand and PBL30 Clave Block (Cowbell Not Included)
ETE1415MQ



Primero
13"x7" Steel Timbale w/ PPS36 Mount
PTE1336



Flat Timbale w/ I.S.S.
13"x3" Steel
PTE313I



Tilting Timbale Stand (Short)
Height Range 26.5" to 36.5"
PT900WS



Primero Timbales
13"x6.5" / 14"x6.5" Steel w/ PT900 Tilting Stand (Stands & Cowbell Included)
PTS5134



Primero Pro Timbales
14"x7" / 15"x7" Steel w/ PT900 Tilting Stand (Sticks Included, Cowbell Not Included)
PTE1415DX

COWBELLS

Pearl and Grammy Award winning artist Horacio Hernández have developed the ultimate family of cowbells. The HH4XH bell features a quick release system that allows the bell to lift easily off of its mount for hand held playing.

HORACIO HERNÁNDEZ
Latin Legend



HORACIO HERNÁNDEZ SIGNATURE COWBELLS



Marybell
HH5

Hand-Held Campana Quick Release
HH4XH

Isabell Mambo Bell
HH4

Chabella
HH3

Clabell
HH2

Bella
HH1

AGOGO & TRIBELLS



Tri-Bells
PTB30

Hand-Held Agogo
ECB22

Mounted Agogo
ECB23

NEW YORKER BELLS



Cha-Cha (High)
BCM3NY

Cha-Cha (Low)
BCM5NY

Mambo
BCM7NY

Marc Quiñones Sig. Timbale Bell
BCM8NYQ

BALA BELLS



Mounted Campana Bell
BCM10

Hand-Held Campana Bell
BCH10

AGOGO & TRIBELLS



Tri Agogo
PTA30

Pro Cowbell Beater
PDC60

Dual Cowbell Beater
PDC10

PRIMERO COWBELLS



10" Bell w/ PPS30
PCB1030

6" Bell
PCB6

4" Bell
PCB4

8" Guiro Cowbell
PCB10GR

10" Millennium Chrome Bell
PCB10MCR

10" Anarchy Bell
PCB20

DJEMBES

Ancient Instruments for the Modern Percussionist

TOP TUNED DJEMBES



12" x 24"
PBJV12685

14" x 25.75"
PBJV14685

#685 Artisan Straight Grain Limba

Seamless Synthetic Shell
w/ Fiber Style Head

ROPE TUNED DJEMBES



12" x 24"
PBJVR12684

14" x 25.75"
PBJVR14684

#684 Artisan Cypress



12" x 24"
PBJV12686

14" x 25.75"
PBJV14686

#686 Artisan Weathered Oak



12" x 24"
PBJVR12685

14" x 25.75"
PBJVR14685

#685 Artisan Straight Grain Limba

DJEMBES are a traditional African instrument that offer a wide variety of sounds and are perfect for drum circles.



Mahogany Djembe
12" Hand Carved
#695 Malinke Village
PBJWR12695

Field Percussion Djembe
14" (Fiberglass)
#649 Textured Black
PJF350FP649

Elite Oak Djembe
12.5"
#511 Natural
PJV340

Elite Fiberglass Djembe
#602 Bistre Black
PJF350 14"
PJF320 12.5"

Fiberglass Fun Drum
PFD300

Djembe Stand - Fits 8" to 14" Pearl Rope Tuned and Top Tuned Djembes
PBJSTD

DJEM-BASS



PJB350
Djem-Bass

The PJB350 Djem-Bass Attachment allows you to convert any Pearl 14" djembe into a sub-sonic bass drum. To reduce the attack and add greater "lows," we have included a cloth cap that stretches around the head. For smoother low-end with a slightly reduced attack, slip the included neoprene disc inside, allowing for two distinct sound options. A pedal (not included) attaches via an I.S.S. clamp to the djembe's stand mounting plate. Includes two legs with mounting hardware, pedal bracket, head cover and neoprene muffler.

FOLKLORIC

FOLKLORIC ELITE CONGAS

Pearl's Folkloric line of congas feature a traditional look with modern innovation that only Pearl can deliver. Each 28" tall Oak drum is designed for the "seated" player, but includes stand mounts for players who prefer to stand. Thicker South American-style natural skin heads make the drums warm-sounding, but a fiberglass gel coating on the interior seals the shell and add the projection and volume desired by today's players. Four Polished Steel Reinforcing Bands are inset on the shell for a smooth touch, and the traditional hoops complete these stunning Cuban instruments.



Folkloric Elite Bongos 7" & 8.5"
PBW300FC

Tumbador 12.5"
PCW125FC

Qunito 11"
PCW110FC

Segundo 11.75"
PCW117FC
#526 CRIMSON SUNRISE



Uno
PSK50FC

Segundo
PSK60FC

Caja
PSK70FC

10" Segundo Shekere
PBSK70

Fiberglass Shekere
PSK10

BATS

Bata drums originated in Nigeria over 500 years ago and were primarily used for religious purposes. The drums were introduced into Cuba by slaves in the 1820's. Pearl Batas are modeled after an ancient Cuban design and feature naturally finished 100% Thai Oak shells for outstanding and authentic tone. Polished steel traditional rims offer excellent tuning integrity and ease of tuning. These prized ceremonial drums have an hourglass shape and produce a great, warm tone similar to a bongo-like sound on the high drum and a djembe-like tone on the large drum.



Itotele
PBA60

Oconcolo
PBA50

Iya
PBA70

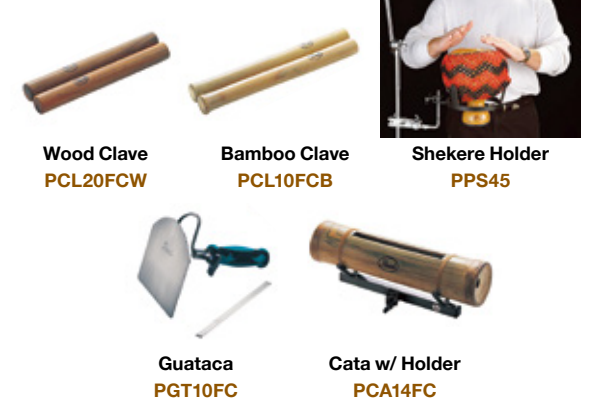

Wood Clave
PCL20FCW

Bamboo Clave
PCL10FCB

Shekere Holder
PPS45

Guataca
PGT10FC

Cata w/ Holder
PCA14FC

BRAZILIAN

BRAZILIAN PERCUSSION

Modern refinements and Pearl quality to the traditional Samba musician.

The Timbao is made from lightweight fiberglass, and is capable of the extremely high tension utilized in tradition Brazilian ensembles. The lightweight wood shell Surdos allow for hours of comfortable play when worn over the shoulder with the provided strap. Available in 18"x22", 20"x18" and 22"x22" sizes (diameter x depth), Pearl's popular Surdos continue to be the industry standard.

Our Repinique features lightweight yet sturdy steel shells with etched heads, shoulder straps and low rims for incredible playing comfort.



Timbao
PBTB140

Tan Tan
PBTA1420

Surdo 20"
PBS2018

Surdo 18"
(Shown with optional PBS30BD)
PBS1822

Surdo 22"
PBS2222

Legs & BD Adapter Kit For Surdo
PBS30BD

Tamborim Stick
PBT70S

PBSM20
Surdo Mallet

PBCX1204
Caixa 12"x4"

PBCX1265
Caixa 12"x6.5"

PBC80SS
Caixa



Repinique 10" w/ Strap
PBR10S

Repinique 12" w/ Strap
PBR12S



Pandeiro 10"
(5 Sets Platinillas & Goatskin Head) w/ Bag
PBP510

Pandeiro 12"
(6 Sets Platinillas & Plastic Head) w/ Bag
PBP612

Pandanza w/ Agogo Bell
PDZ510

Tamborim w/ Quick Draw Mount
PBT60C

CAJONS

Get in the Cajon Zone!



19.25" T x 11.75" W x 11.75" D

Primo Music Genre Cajon PBC124B

| | |
|-----------|---|
| FACEPLATE | Meranti* |
| BODY | Medium-Density Fiberboard |
| SNARES | Fixed, two sets |
| BASS PORT | Patented, built in, rear facing |
| FINISH | Crate style body with graphic faceplate |

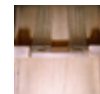

TWO SETS SNARES

Features Pearl's crate design and the faceplate displays the names of some of the most popular musical genres.

18.25" T x 14" W x 14" D

Primo Coffee Bean Cajon PBC320

| | |
|-----------|---|
| FACEPLATE | Meranti |
| BODY | Meranti Plywood |
| SNARES | Fixed, three sets |
| BASS PORT | Patented, built in, rear facing |
| FINISH | Crate style body with graphic faceplate |



THREE SETS SNARES

The Coffee Bean cajon features Pearl's crate design and the faceplate resembles a crate of Peruvian coffee beans.

19.25" T x 11.75" W x 11.75" D

Primo Acme Cajon PBC125B

| | |
|-----------|---|
| FACEPLATE | Meranti* |
| BODY | Meranti Plywood |
| SNARES | Fixed, two sets |
| BASS PORT | Patented, built in, rear facing |
| FINISH | Crate style body with graphic faceplate |



BASS PORT

The Acme Explosive cajon features Pearl's crate design and the faceplate resembles a crate of explosives.

19.25" T x 11.75" W x 11.75" D

Willie S. Sparks Electric Cajon PBEC210

| | |
|-----------|----------------------------------|
| FACEPLATE | Meranti* |
| BODY | Meranti Plywood |
| SNARES | Fixed, two sets |
| BASS PORT | Patented, built in, rear facing |
| FINISH | Wood body with graphic faceplate |



1/4" JACK

Plug in your cajon with a 1/4" jack and amplify the sound of your Willie Seymour Sparks electrified beat generator.

19.25" T x 11.75" W x 11.75" D

Primo Music Town Cajon PBC122B

| | |
|-----------|---|
| FACEPLATE | Meranti* |
| BODY | Medium-Density Fiberboard |
| SNARES | Fixed, two sets |
| BASS PORT | Patented, built in, rear facing |
| FINISH | Crate style body with graphic faceplate |

The Music Town USA cajon is designed to resemble a wooden crate and the faceplate features the names of some of America's iconic music cities.

19.25" T x 11.75" W x 11.75" D

Primo Tree of Life Cajon PBC123BTR

| | |
|-----------|--|
| FACEPLATE | Meranti* |
| BODY | Medium-Density Fiberboard |
| SNARES | Fixed, two sets |
| BASS PORT | Patented, built in, rear facing |
| FINISH | Hand painted and silkscreen Tree of Life |

The Tree of Life cajon features a hand painted and silkscreen design that wraps around three sides and depicts the Tree of Life.

19.25" T x 11.75" W x 11.75" D

Primo Raven Cajon PBC123BBR

| | |
|-----------|---|
| FACEPLATE | Meranti* |
| BODY | Medium-Density Fiberboard |
| SNARES | Fixed, two sets |
| BASS PORT | Patented, built in, rear facing |
| FINISH | Hand painted and silkscreen black raven |

The Raven cajon's finish is a hand painted and silkscreen design that wraps around 3 sides featuring a stylized black raven.

19.25" T x 11.75" W x 11.75" D

Primo Abstract Red Cajon PBC120B

| | |
|-----------|--|
| FACEPLATE | Meranti* |
| BODY | Medium-Density Fiberboard |
| SNARES | Fixed, two sets |
| BASS PORT | Patented, built in, rear facing |
| FINISH | Abstract Red body with black faceplate |

Its unique finish is an abstract red print on a cloth sarong that is applied to the body of the cajon and is accentuated by the ebony front.

*FACEPLATE REPLACEMENT MODEL: **FP123B**



19.25" T x 11.75" W x 11.75" D

Primo Figured Cherry Cajon PBC121B

| | |
|-----------|--|
| FACEPLATE | Figured Cherry* |
| BODY | Medium-Density Fiberboard |
| SNARES | Fixed, two sets |
| BASS PORT | Patented, built in, rear facing |
| FINISH | Natural Figured Cherry w/ gloss black body |

Features a stunning figured Cherry faceplate. Because of its hardness, tonally cherry is a close match to maple and when used on a cajon provides more bottom-end.



18.75" T x 12.5" W x 12.5" D

Jingle Cajon PCJ629616

| | |
|-----------|-------------------------|
| FACEPLATE | Asiatic hardwood |
| BODY | Fiberglass |
| SNARES | Fixed, three sets |
| BASS PORT | Rear facing |
| FINISH | #616 Artisan Wood Grain |

Simply twist open the Brazilian Platinella-style jingles and a new world of sonic options open up, as you sound like two percussionists blending simultaneously.



18.75" T x 12.5" W x 12.5" D

Boom Box Cajon PCJ633BB635

| | |
|-----------|-------------------------|
| FACEPLATE | Asiatic hardwood |
| BODY | Fiberglass |
| SNARES | Fixed, three sets |
| BASS PORT | Rear facing |
| FINISH | #635 Artisan Zebra Wood |

The Boom Box Cajon creates never-before-heard low-end frequencies from a Fiberglass cajon! Features a fixed snare system and a built-in bass port for subsonic frequencies you have to hear to believe!



18" T x 14" W x 14" D

Primo Bass Boom Cajon PCJ1418BBM2

| | |
|-----------|-----------------------------------|
| FACEPLATE | Meranti |
| BODY | Medium Density |
| SNARES | Fixed, three sets |
| BASS PORT | Built in, rear facing |
| FINISH | Crimson body with black faceplate |

Traditional style, classic look, amazing sound. The Bass Boom cajon will get the job done in style.

*FACEPLATE REPLACEMENT MODEL: **FP123B**

CAJON ACCESSORIES



Cajon Holster Nylon w/ Velcro Straps
CAJH100



Seat Cushion w/ Thick Foam. Adds comfort for long sessions.
PSCBC



Box Cajon Case 13" x 14" x 20"
PSC1213CJ



Cajon Stand
PCJ70STD

HANDPANS

A Cosmic Blend of Sound

MELODIC HANDPAN



22" Melodic Handpan
9 Note D Minor - Patina Finish
PBHP500

Handpans are musical instruments that are a subset of the steelpan. The beautiful tonal characteristics will remind you of steel drums, but handpans are only played by hand, with no sticks or mallets, so the sound has reduced attack but is much more mellow.

The shape of Pearl's 22" Awakening Series Melodic and Euphonic handpans feature a center tone field surrounded by eight tone fields. Each tone field has a fundamental note, an octave, and an overtone, so each field has three notes. The hand-crafted steel construction of the instrument is designed so each tone field holds its tuning.

The Melodic handpan features a patina finish and is meticulously tuned to the D Minor scale, and responds to your finger strikes with excellent sonority.



Hand Hammered Tone Field

Rubber Edge Protection

Padded Case Included

EUPHONIC HANDPAN

The gray Euphonic handpan is designed for budget-conscious players and tuned to F Minor. Both models include a sturdy, PVC reinforced backpack-style bag to protect the handpan during travel and storage. Tabletop and floor stands are also available but sold separately.



Case Included

22" Euphonic Handpan
9 Note F Minor - Gray Lacquer Finish
PBHP300G

HANDPAN ACCESSORIES

NOTE: Items pictured are not to scale



Handpan Table Top Stand
PTTD10

Handpan Floor Stand
PBFS30

Handpan Case
PBHPB50

TONGUE DRUMS

Engineered for the Professional Percussionist



AWAKENING SERIES TONGUE DRUMS
Pearl proudly introduces the Awakening Series of 6 Tongue Drums: Three 8 note and three 9 note drums tuned to pentatonic scales.

Tongue drums derive their name from the tongue shaped areas where you strike the drum. The results are a cosmic blend of tones that are as much fun to hear as play.



8 Note G Major #687 Blue Burst
PMTD8GMF687

8 Note A Ake Bono #688 Brown Burst
PMTD8AKBF688

8 Note A Minor #689 Green Burst
PMTD8AMF689



9 Note C Lydian #690 Orange Burst
PMTD9LYDF690



9 Note C Major #691 Crimson Burst
PMTD9CPTF691



9 Note C Ake Bono #692 Purple Burst
PMTD9AKBF692

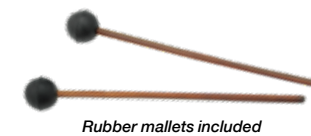

Rubber mallets included

Each drum features a 10" hardened steel shell with precise laser cut tongues for accurate and consistent tuning. Pearl Tongue drums can be played with your fingers or with a set of mallets included with each drum.

9 Note C Ake Bono
#692 Purple Burst
PMTD9AKBF692

TONGUE DRUM BAG



Tongue Drum Bag
PTDB10B

AWAKENING SERIES

Rainsticks and Nut Shakers

RAINSTICKS

BAMBOO RAINSTICKS WITH BURNED FINISH #694 RHYTHM WATER



Pearl's natural Bamboo Rainsticks are 2.5" in diameter and feature an internal spiral maze of tines that a cascade of lava pebbles flow over to create the soothing sound of falling rain.

Pearl has expanded its line of shakers to include six Bamboo rainsticks ranging in size from 16" to 60" and available in two unique finishes.



BAMBOO RAINSTICKS WITH PAINTED FINISH #693 HIDDEN SPIRIT

NUT SHAKERS

The Awakening Series has been expanded to include a series of natural nut shakers that provide earthy tones that complement the series. Kenari, Bendo, and Pangli nuts range in size from small, medium, and large and each size

possesses unique sound properties. From the recording studio to the yoga studio Pearl's Awakening Series has an instrument and sound that will inspire you.



Pangli Nut Shaker w/ Rope Handle
PBPGRH14

20 INDIVIDUALLY STRUNG PANGI NUTS
Deeper, earthy tone.

Pangli Nut Shaker w/ Bamboo Handle
PBPGBH12

BAMBOO HANDLE
Gives player more control.

Bendo Nut Shaker w/ Rope Handle
PBBDSKRH

16 STRANDS OF BENDO NUTS
Bright, woody tone.

Kenari Nut Bracelet Shaker
PBGLKEN

14 HAND STRUNG KENARI NUTS
Worn to layer sounds.

PBKENCH01
26 Kenari Nut Wind Chime *Clamp not included

MAHOGANY CROSS BAR
Suspended nuts for unique earthy sounds.

Kenari Nut Shaker 7"
PBSHKENL

22 STRANDS OF KENARI NUTS
Full, robust tone.

CONCERT PERCUSSION

Engineered for the Professional Percussionist



Pearl is proud to offer Concert Percussion instruments that are attractively priced for school ensembles, yet engineered with the professional percussionist in mind. The symphonic tambourine is a perfect example. Its 17 pairs of specially aged, stamped brass jingles provide a dry, yet bright tone that brings added color to any musical situation. Its 10" headed wood frame allows the

player to effortlessly perform all tambourine techniques, and the tambourine's plush carrying case is included. The rattler is another vital component to any concert percussionists' equipment, and Pearl's is built with an extended handle for a comfortable grip and ease of playing. Holders for the rattler and castanets are also available.



Mix Copper And Brass
PETM1018CR

Mix Copper and Bronze
PETM1018CB

Mix German Silver and Copper
PETM1018GC

Beryllium Copper
PETM1018CP

German Silver
PETM1018GS

ORCHESTRAL TAMBOURINES

The Pearl Orchestral Series Professional Tambourines provide performers a new voice and sound for any performing situation. These 5 instruments feature uniquely sourced and hand-

hammered jingles combinations of German Silver, Phosphor Bronze, Beryllium Copper, and Yellow Brass that give a full spectrum of color and projection options to players. The 10" shell is a well-balanced and lightweight 2-ply Mahogany

design with contoured hand-hold areas for comfortable performance and warm tone. The natural finish goatskin head provides a full responsive sound and traditional look without sacrificing durability.



16" Ocean Drum
PSFM16

14" Frame Drum
PFR14C

Frame Drums Set of 6 - Sizes: 8", 10", 12", 14", 16", 18"
PFR0818C



Castanets (Long Handle)
PCN20

Castanets
PCN20S

Castanets Holder
PCN20H

Slap Stick
PSS100

(High)
PCWB100A

(Medium)
PCWB200A

(Low)
PCWB300A

Mounting Bracket incl.



Stix-Free Triangle Holder w/ 8" Triangle
PPS12T

Triangle
10" **PET100**
8" **PET80**
6" **PET60**

Triangle Beater
PETB30

Triangle Clip
PTC10

Rattler Mounting Clamp
PRT10C

Temple Blocks
PCWTB05

Rattler
PET100

HAND PERCUSSION

A World of Hand Percussion

BLOCKS, BELLS, SHAKERS and more. Choose from a complete selection of hand percussion instruments to add color and impact to your music.



Natural Gourd Guiro
PNG20

Two scraping surfaces: thin grooves on one side for a lighter sound and thicker cut channels on the other side for a beefier sound. The interior is coated with a fiberglass get to add projection and volume.



Metal Guiro
PMG20

Perfect for Merengue rhythms, or just a different metallic sound texture, Pearl's Metal Guiro will become an essential ingredient in your "toy" bag. Scraper included.



Fiberglass Guiro
PFG20

Pearl's Fiber Guiro is light-weight and provides optimal projection due to its fiberglass construction. With the included striker and two different playing surfaces you have a world of sonic possibilities in your hand.



Guiro Holder
PGH20

This innovative design will hold virtually any size guiro secure for one handed playing. Easily mountable off the lug of your conga or any 3/8" post, Pearl's Guiro Holder uses a track system to lock the guiro in place. Included is a 3/8" "Z" rod so you can also mount your favorite accessory as well.



Beaded Maracas
PFM20

The Beaded Maracas feature Shekere-style beads which offer an excellent sound with greater control, and foam handles for enhanced comfort.



Maracabasa
PFM50

The Maracabasa is two great instruments in one, combining the functionality of a maraca and a cabasa in one handheld instrument. Featuring a ribbed fiberglass body wrapped in shekere-style beads.



Basket Ganza 9" X 4"
PGA20

The Pearl basket ganza is a 9"x4" woven tube containing wooden sticks instead of conventional shot. The wood sticks produce an airy percussion sound.



Shakelets
PWR40

This innovative percussion item feature exclusive "Ganzinellas", Brazilian-style plantinellas combined with ganza shakers that are worn on the wrists to produce a shaker sound when playing.



Spirit Chimes w/ Holder and Mallet
PSC30BR

Spirit Chimes have many applications in school bands, percussion ensembles and music programs. They are also perfect for meditation and yoga studios.



36 Anodized Aluminum Chimes w/ Case, Holder, And Striker
PWCH3620A

- Satin black frame with polished bars
- Self-dampening parallel swinging chimes



32 Gold Anodized Aluminum Chimes w/ Case, Holder, and Striker
PWCH3220G

- 32 Gold anodized aluminum chimes
- Self-dampening parallel swinging chimes



32 Bar Aluminum Windchimes w/ Case, Holder, and Striker
PWCH3220A

- 32 Anodized Aluminum Chimes
- Self-dampening parallel swinging chimes



Foldable 36 Anodized Aluminum Chimes
PWCHF3620AF

- Individually strung, goes from 19.25" to 9.75"
- Self-dampening parallel swinging chimes



Quickmount Tambourine w/ Steel Jingles
PTM10SHX

Six double rows of premium steel jingles deliver a bright metallic sound. Features a comfort grip handle that slides into the shock-absorbing Quickmount bracket. Mounts to any 3/8" post.



QUICKMOUNT BRACKET
Hand-held to mounted in seconds.



Quickmount Tambourine w/ Brass Jingles
PTM10GHX

Six double rows of premium brass jingles deliver with bright and a warm metallic sound. Comfort grip handle that slides into the shock-absorbing Quickmount bracket. Mounts to any 3/8" post.



COMFORT GRIP HANDLE
Molded ergonomic shape.



PTM50BHR (Brass)
Ultra Grip Volume Adjustable Tambourine



PTM50SHR (Stainless Steel)

The jingle control discs can be moved to the outside to allow the jingles to ring freely. As the jingle control discs are tighten the more restricted the jingle.

Brass is an alloy of copper and zinc and the jingles provide a bright mid-range tone. Steel jingles have a higher tone with extra top end and sustain.



9" Primero Rock Tambourine w/ Millennium Jingles
PTM09BK

The Primero Rock Tambourine features 6 double sets of Millennium Chrome Jingles in a matte black oval frame.



Headless Wood Tambourines
PTH10B (Brass)
PTH10S (Stainless Steel)

Brass is an alloy of copper and zinc and the jingles provide a bright mid-range tone.



Stainless Steel jingles produce a higher tone with extra top end and sustain.



Hi-Hat Jingle Ring
PJH10SH

The Hi-Hat Jingle Ring has 20 sets of Stainless Steel tambourine style jingles that will accentuate your Hi-Hat sound with every opening and closing of your cymbals.



Gatting Cabasa
CBS100

Simply grab the precision handle and fire away to play any pattern you wish, or keep spinning it for an infinite "sizzle" that is not possible with standard Cabasas.

ASH TONE BLOCKS



Tang-Tang
PTG20

A high and low pair of unique shakers that incorporate a Caxixi-Style Plate and Wooden "Clacker."



PAB20 (High)
PAB50 (Medium)
PAB100 (Low)

Pearl's Ash Tone Blocks are constructed using Ashwood because it is extremely hard and durable. The Ash Tone Blocks are pitched in "thirds" and each block includes a mounting bracket that accepts a 3/8" post.

CLAVE BLOCKS



PBL10 (High)
PBL20 (Medium)
PBL30 (Low)
PBL100 Anarchy Block

Pearl's clave blocks are injection molded so they're virtually indestructible, and the solid color will never chip, fade, or peel. Our exclusive CDV (Chamber Density Variation) Technology process allows all three clave blocks to be the same dimensions but still differ in pitch.

Produces a low piercing pitch that will cut through even the heaviest metal rhythm section.



21" Field Percussion Shaker
PGA60FP

Hexagonal body and internal chamber for a truly massive sound.



Wood Hex Ganzas
PGA30W (Short) **PGA32W** (Long)

The wood Hex Ganzas are made from Shorea wood and maintain the same strong projection as their aluminum brothers, but deliver a warmer less metallic tone.



Hex Ganzas
PGA30 (Short) **PGA32** (Long)

The Pearl aluminum Hex Ganzas give more sound control than round shakers and produce a lush shake sound due to their hexagonal shape.



Triple Shaker
PGA40

6" long, rectangular aluminum shaker provides three unique sounds: shake, click, and swish.



Egg Carton
PEC1

Three egg shakers in a clear tube that can be played separately or as a complete unit.

STANDS, BAGS, HOLDERS

Pro Tools for Every Gig

CONGA STANDS



Quick Release Double Conga Stand w/ Bag
PC3000TW



Quick Release Double Conga Stand
PC300W



Pro Conga Stand
PC3000



All-Fit Conga Stand
PC900

The **PC3000TW** stand holds full size professional congas as securely as most stands double its weight and mass.

The **PC300W** is scaled down to support our lighter Primero Conga lineup. Both stands setup in seconds because there are no wingnuts needed to mount your congas.



Primero Twin Conga Stand
PC200



Ultra Lite Conga Stand
PC2500



Primero Basket Conga Stands
PC100P (10) PC110P (11)

The **PC2500** Ultralite Conga stand, is lightweight yet sturdy and stable. Index markings on all adjustable parts make for consistent lightning fast setups.

BONGO STANDS



Pro All Fit Bongo Stand with Spring Loaded Strap Hinge
PB3000



Bongo Stand for Seated and Concert Player
PB3000S



All-Fit Tilting Bongo Stand
PB900LW



Lightweight Bongo Stand
PB700



Bongo Attachment for PC200
PB700BHS

DJEMBE STANDS



All Fit Djembe Stand
PC800S



Pro Djembe Stand
PD3000



All-Fit Djembe Stand
PC800S

HEIGHT: 16" to 21"

CAJON STANDS



Cajon Stand
PCJ70STD

TRAP TABLES

Pearl's wide selection of trap tables and accessories feature sturdy and dependable options for any musical situation. Options include a variety of sizes, construction materials, tables with stands, tray tops and table tops only and single or double braced legs.



Trap Table Single Braced (18" x 24")
PTT1824

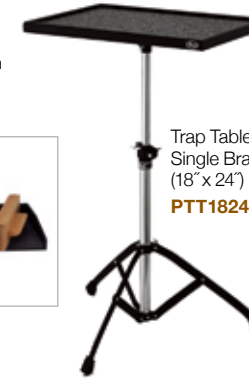

Trap Table Double Braced (18" x 24")
PTT1824W



Aluminum Trap Table (15" x 24") w/o Stand
PTT1524MPT



Aluminum Trap Table (15" x 24") w/ Stand
PTT1524MPW



Tech Tray (8.5" x 11")
PTT8511



Trap Table (12" x 12")
PTT1212



(Table & Stand Sold Separately From Rack)
Universal Trap Table Rack
PTRUNV

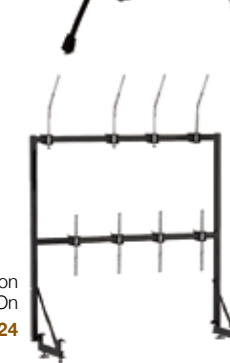

Percussion Rack Add On
PTR1824



3/8" Straight Post
PTR1824RC1



3/8" Angled Post
PTR1824RC2



Post Attachment
PTR1824RC6



(FOR PTT1824, PTT1212)
Trap Table Single Post Adapter
PTR1824RC3

PERCUSSION CASES

Features include: ergonomic carrying straps, rubber protective bottoms, top-mounted carrying handles, tuning wrench pouches, & heavy duty double zippers.



Box Cajon Case 13" x 14" x 20"
PSC1213CJ



Travel Conga Case
PSC1175TC

Fits Havana Series



11" & 11.75" Conga Bag
PSC117CGW



12.5" Conga Bag
PSC125CGW



12" Djembe Bag
PBJCXL



14" Djembe Bag
PBJCXXL

12.5" Conga Bag
PSC125CG



Bongo Bag
PSCBB



11" Conga Bag
PSC110CG

PSC125CG Fits 11.75" & 12" Congas



14" Djembe Bag
PSC140DJ

HOLDER & ACCESSORIES



Angled Post Adapter
PPS37



Lug Mount Accessory Holder
PPS40



Universal Guiro Holder
PGH20



Foot Pedal Bracket
PPS20



Cowbell Stacker
PCS10



Stix-Free
PPS10 & PPS11



Percussion Toy Box (Accessories Not Included)
PTYB1212

COWBELL HOLDERS



CA130



75H



75X



PPS81



PPS82

NOTE: Items pictured are not to scale

REPLACEMENT PARTS

Pearl offers a tremendous number of parts for our drums and hardware. The parts represented on these pages are some of the most commonly requested items.

MASKING COVERS & MOUNTING BRACKET

The GK90 and BBC1 cover the holes of BT3 and BB3 brackets that have been removed.



- BBC1** For BB3, w/Gasket, Screws and Nuts
- GK90** For BT3, inside/outside plates w/ Bolts
- BT3** Tom Tom Bracket

BASS DRUM HOOP PROTECTORS



- HPP2** Metal Hoop Protector for Wood BD Hoops
- NP01** Hoop Protector for Metal BD Hoops
- NP347/2** Non-Slip Hoop Protector for Wood BD Hoops (pair)

P2050 SERIES CAMS



ELIMINATOR OPTION CAM

- CAMPL** Purple Cam, Aggressive Action
- CAMYL** Yellow Cam, Inverse Action
- CAMTBK** Translucent Black Cam, Linear Action
- CAMTWT** Translucent White Cam, Oversized Linear Action
- CAMTBL** Translucent Blue Cam, Progressive Action
- CAMTRD** Translucent Red Cam, Radical Action

FLOOR TOM LEGS & BRACKETS



- FTL07C/3** Floor Tom Legs (3 Legs)
- LG40L/3** Long Floor Tom Legs (3 Legs)
- LB40** Leg Bracket for Masters Series

HI-HAT CLUTCHES & PARTS

RAPID LOCK HI-HAT CLUTCHES

Hi-Hat set-up and tear-down is a breeze with Rapid-Lock's Patented* two-point quick release locking system. *U.S. Patent #9355625

- HCL205DQR** Rapid Lock Quick Release Hi-Hat Drop Clutch w/ Locking Nut
- HCL205QR** Rapid Lock Quick Release Super Grip Hi-Hat Clutch w/ Locking Nut
- HCL105QR** Rapid Lock Quick Release Hi-Hat Clutch w/ Locking Nut
- HCL79** Hi-Hat Clutch Complete



CHAINS & BELTS



- CCA5** Chain Assy Complete for Eliminator Pedals
- BCA250** Belt Assy Complete for P2050 Eliminator Pedals

SPRING



- SP64F** Spring for P930/P932

BEATERS & BEATER WEIGHTS



- DB100** Duo-Beater Felt/Plastic
- B250QB** Control Core Quad Beater
- B350XR** Extreme Impact Beater

BEATER WEIGHTS

- BW100** Beater Weight, 3 Weights in One (U.S. Patent #7122730)

MASTERCAST HOOPS

MasterCast are the finest die cast hoops available and feature the perfect blend of thickness and mass to improve the depth, clarity, and focus of toms and snare drums.



| Model # | Diameter | # of Tension |
|----------|----------|------------------------|
| DC0805 | 8" | 5 |
| DC1006 | 10" | 6 |
| DC1206 | 12" | 6 |
| DC1306 | 13" | 6 |
| DC1308 | 13" | 8 |
| DC1308S | 13" | 8 Snare Side |
| DC1408 | 14" | 8 |
| DC1408S | 14" | 8 Snare Side |
| DC1410 | 14" | 10 |
| DC1410S | 14" | 10 Snare Side |
| DC1410SG | 14" | 10 Snare Side w/ Guard |
| DC1508 | 15" | 8 |
| DC1608 | 16" | 8 |
| DC1808 | 18" | 8 |

SUPERHOOP II

SuperHoop II hoops are precision formed from heavy-duty 2.3mm steel, triple-flanged and engraved with the SuperHoop II logo.



| Model # | Diameter | # of Tension |
|----------|----------|-----------------------|
| SH0604 | 6" | 4 |
| SH0805 | 8" | 5 |
| SH1006 | 10" | 6 |
| SH1006S | 10" | 6 Snare Side |
| SH1206 | 12" | 6 |
| SH1208 | 12" | 8 |
| SH1208S | 12" | 8 Snare Side |
| SH1306 | 13" | 6 |
| SH1308 | 13" | 8 |
| SH1308S | 13" | 8 Snare Side |
| SH1408 | 14" | 8 |
| SH1408S | 14" | 8 Snare Side |
| SH1410B | 14" | 10 |
| SH1410S | 14" | 10 Snare Side |
| SH1410SG | 14" | 10 Snare Side w/Guard |
| SH1508 | 15" | 8 |
| SH1510S | 15" | 10 Snare Side |
| SH1510B | 15" | 10 |
| SH1608 | 16" | 8 |
| SH1808 | 18" | 8 |

STEEL HOOPS

| Steel Hoop Model # | Diameter | # of Tension |
|--------------------|----------|--------------|
| RH0804 | 8" | 4 |
| RH1006 | 10" | 6 |
| RH1206 | 12" | 6 |
| RH1306 | 13" | 6 |
| RH1408 | 14" | 8 |
| RH1408S | 14" | 8 Snare side |
| RH1608 | 16" | 8 |
| RH1808 | 18" | 8 |



BASS DRUM PEDAL TRAINING PAD

The BD10 bass pad is perfect for practicing at home or on the road. The wide pad accommodates double pedals and is specially formulated for extremely low noise and a realistic feel. The universal-fit "hoop" accepts all brands of pedals and adjusts to compensate for different floor surfaces. The BD10 folds for compact transport.



- BD10**

QUICK RELEASE WINGLOC



- WL230** Quick Release WingLoc
- WL230A** Quick Release WingLoc Complete

SEAT CUPS AND FELTS



- RC20** Reversible Seat Cup, w/ O-Ring (U.S. Patent #6940006)
- PL11** Cymbal Seat Cup
- FLW001/2** Cymbal Felt Washer (2 Pieces)
- FLW003** Hi-Hat Cup Felt Washer

STOP LOCK



- ZD081A** Stop Lock Complete

DRUM KEYS



- KGT100H** Gyro Tune Key w/ Quick Release
- K030** Hi-Tension Tuning Key
- K080** Tuning Key

AIR SUSPENSION FEET



- R40/3** Air Suspension Rubber Feet (3 Each)
- R5/3** Rubber Tip (3 Each)



RF ONE / MASTERS SHOWN WITH MASTERCAST HOOPS



PROFESSIONAL SERIES SHOWN WITH SuperHoop II HOOPS

LUGS

- CL05** Lug for 3" Piccolo Snare
- CL55** Lug for 5" & 5.5" Deep Snare
- CL65** Lug for 6" & 6.5" Deep Snare
- CL100** Lug for over 7" & 8" Deep Snare



REPLACEMENT PARTS

Pearl offers a tremendous number of parts for our drums and hardware. The parts represented on these pages are some of the most commonly requested items.

OPTI-LOC



OPL1016/C

Opti-Loc suspension tom holders provide exceptional stability while greatly improving resonance and sustain. (For EXX / EXL Export / DMP)

- OPL0608/C Opti-Loc for EXX and DMP 6"-8" Diameter
- OPL1016/C Opti-Loc for EXX and DMP 10"-16" Diameter

R2 AIR & OPTIMOUNT

To attain tonally true sound, every drum would have to be mounted in a floating point at the center of its shell. R2 Air equally balances mounting pressure across two floating points at the top and bottom of each tom. This gives true tonal separation from mounting hardware and enhances sonic output. U.S. Patent #11640814



R2AS100708C



JUNGLE GIG



JG16

JG16 • Pearl's Jungle Gig allows the conversion of a 16" Floor Tom to a Bass drum.



Our OptiMount Suspension System attaches to the tom's tension rods and floats on rubber cushions, providing the ultimate in stability while allowing the drum to resonate fully without restriction.



OPT0708 OPT0910 OPT1112



OPT1314 OPT1516

- OPT0708 / for drums 7"-8" deep, 8"-16" diameter
- OPT0910 / for drums 9"-10" deep, 8"-16" diameter
- OPT1112 / for drums 11"-12" deep, 8"-16" diameter
- OPT1314 / for drums 13"-14" deep, 8"-16" diameter
- OPT1516 / for drums 15"-16" deep, 8"-16" diameter

MUFFLERS

External clamp-on muffler for snare drums and toms. By adjusting the pressure and position of the felt pad, excessive overtones can be precisely controlled or eliminated.



OM1

- OM1 Clamp-on Muffer, Snare Drum & Toms

MUFFLE HEADS

| Model # | Size | Model # | Size |
|---------|------|---------|------|
| MFH08 | 8" | MFH14 | 14" |
| MFH10 | 10" | MFH16 | 16" |
| MFH12 | 12" | MFH20B | 20" |
| MFH13 | 13" | MFH22B | 22" |

BASS DRUM MUFFLER



BDMF

BDMM

- BDMF Bass Drum Muffer (Full Size)
- BDMM Bass Drum Muffer (Mini Size)

TENSION ROD LOCKNUTS



TNK10N/10

TL20/10

- TNK10N/10 Tension Keeper (10/pkg)
- TL20/10 Tension Rod Lock Nuts (10/pkg)

TENSION ROD WASHERS



NLW12B/12

MTW12/12

- NLW12B/12 Nylon Washers (12) Black
- MTW12/12 Metal Washers (12)

STRAINERS



SR017

- SR014N Standard Snare Strainer
- SR017 Snare Strainer Complete
- SR018 Snare Strainer Complete



ON

OFF

THE SR017 STRAINER Simple and effective, the SR017 is a Pearl standard for effortless snare switching and sensitivity control. Its smooth lever action and fine-tuning knob let you dial in the right amount of snare wire saturation to suit your personal sound.

ULTRA-SOUND SNARES

Pearl's Ultra-Sound snares feature patented Graduated Tension wires for extended dynamic range from ultra soft to ultra loud. Ultra-thin, low mass end plates assure ultra quick response. The end plates feature three mounting options: tunnels or holes for cord mounting and slots for straps. U.S. Patent #7202405

20 / I 20 / D 20 / C



- SN1320C 20 strands for 13", C-type, w/ straps & cords
- SN1320D 20 strands for 13", D-type, w/ straps & cords
- SN1320I 20 strands for 13", I-type, w/ straps & cords
- SN1420C 20 strands for 14", C-type, w/ straps & cords
- SN1420D 20 strands for 14", D-type, w/ straps & cords
- SN1420I 20 strands for 14", I-type, w/ straps & cords

42 / I 42 / D 42 / C



- SN1442C 42 strands for 14", C-type, w/ straps & cords
- SN1442D 42 strands for 14", D-type, w/ straps & cords
- SN1442I 42 strands for 14", I-type, w/ straps & cords

REPLACEMENT SNARES



SPS18/6
SNC500R/4

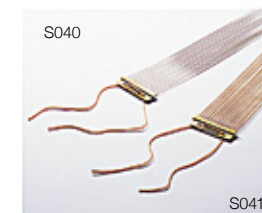

S040

S041

- S022N 20 Strand for 14" w/ Cords
- S022NU 20 Strand for 14" w/ Cords, Uncoated
- S022 20 Strand for 14" w/ Straps
- S025 20 Strand for 14" long, w/ Straps
- S029N 20 Strand for 13" w/ Cords
- S030N 24 Strand for 14" w/ Cords
- S031N 20 Strand for 12" w/ Cords
- S032N 16 Strand for 10" w/ Cords
- S033N 16 Strand for 12" w/ Cords
- S040 15 Strand for 14" w/ Cords, Steel Cable, Thinner Gauge
- S041 15 Strand for 14" w/ Cords, Bronze Cable, Thicker Gauge
- SPS18/6 Plastic Strap (6/pkg)
- SNC500R/4 Snare Cord (4/pkg)

STAINLESS STEEL TENSION RODS

Pearl's Stainless Steel Tension Rods are machined, not forged, from a single piece of stainless steel to the most exacting tolerances in the industry. They feature super-smooth, precise tensioning, with absolutely no play. Each non-plated stainless steel tension rod is matched with a precision-machined brass swivel nut for ultra-precise performance.



- SST5028/6 W7/32 x 28mm (6)
- SST5035/6 W7/32 x 35mm (6)
- SST5038/6 W7/32 x 38mm (6)
- SST5042/6 W7/32 x 42mm (6)
- SST5047/6 W7/32 x 47mm (6)
- SST5052/6 W7/32 x 52mm (6)
- SST6115 M6 x 115mm

TENSION RODS

- T055/6 W7/32 x 28mm (6) for 3" Deep Snare
- T060/6 W7/32 x 35mm (6) for Free Floaters before 2002
- T061/6 W7/32 x 42mm (6)
- T061L/6 W7/32 x 47mm (6) for 6.5" Deep Snare
- T062/6 W7/32 x 52mm (6) for 5.5" Deep Snare
- T065 M6 x 90mm (Bass Drum)
- T066 M6 x 115mm (Bass Drum)
- TR5052 W7/32 x 52mm (DMP, EXL, EXX, MDT Snare)
- TR5047 W7/32 x 47mm (DMP, EXL, EXX, MDT Toms)
- TR5100 W7/32 x 100mm (Bass Drum)



T055/6

T060/6

T061/6

T061L/6

T062/6

T065

T066

PEARL ARTISTS

VIEW ALL THE PEARL ARTISTS AT:



AARON SMITH
Independent



ADAM TUMINARO
OrlandoDrummer



ADRIAN BENT
Drake/Daniel Caesar



ARE-JAY HALE
Halestorm



ALVIN FORD
Trombone Shorty



EDDIE BAYERS
Nashville Legend



ELISE TROUW
Independent



ERIC SINGER
KISS



FLO MOUNIER
Cryptopsy



FREDO ORTIZ
Los Lobos



ANDREW TKACZYK
The Ghost Inside



AUSTIN BURCHAM
ABBDRUMS



BAARD KOLSTAD
Leprous



BARRY KERCH
Shinedown



BEN GORDON
Parkway Drive



GABE HELGUERA
I Prevail



GENE HOGLAN
Dethklok



GEORGE KOLLIAS
Nile



GREG HUTCHINSON
Independent



GREYSON NEKRUTMAN
Independent



BEN JOHNSTON
Biffy Clyro



BILLY HART
Jazz Legend



BRANDON PERTZBORN
Suicidal Tendencies / DJ Premier



BRANDON COMBS
Leon Bridges



BRIAN FRASIER-MOORE
Justin Timberlake / Pink



HARRY MIREE
Hardy



HORACIO HERNÁNDEZ
Latin Legend



IAN PAICE
Deep Purple



INFERNO
Behemoth



ISAC JAMBA
Independent



BRUNO ESRUBILSKY
Mitski



BRUNO VALVERDE
Angra



CALVIN RODGERS
Independent



CASEY COOPER
@COOP3RDRUMM3R



CHAD SEXTON
311



JASON BITTNER
Overkill / Shadows Fall



JASON BOWLD
Bullet For My Valentine



JASON HARTLESS
Ted Nugent / Studio



JEFF MARINO
Darius Rucker



JEN LEDGER
Skillset / Ledger



DAN PRESLAND
Ne Obliviscaris



DANIEL ERLANDSSON
Arch Enemy



DARION JA'VON
Doja Cat



DENNIS CHAMBERS
Drumming Legend



DESMOND DAVIS
Mickey Guyton



JERROD SULLIVAN
The 4 Korners



JESSIE CARABALLO
Marc Anthony



JOCKE WALLGREN
Amon Amarth



JOE TOMINO
Sublime with Rome / Dub Trio



JOEY JORDISON
In Memoriam

PEARL ARTISTS

VIEW ALL THE PEARL ARTISTS AT:



JOEY KRAMER
Aerosmith



JOHN LONGSTRETH
Origin



JON LARSEN
Volbeat



JONATHAN MOVER
Independent



JUAN "CARLITO" MENDOZA
Independent



MORGAN ROSE
Sevendust



NATE MORTON
The Voice



OMAR HAKIM
Independent



PETAR JANJIC
Cory Wong



PETE WEBBER
Havok



KAI HAHTO
Nightwish



KEIO STROUD
Independent



KENT SLUCHER
Luke Bryan



KENWOOD DENNARD
Independent



KIKO FREITAS
Independent



QUINTON "Q" ROBINSON
Independent



RAY LUZIER
Korn / KXM



RICCARDO MERLINI
Independent



RICKY LEWIS
The Weeknd



ROBBY AMEEN
Independent



KRIS BOWERING
Orville Peck



KRIS MYERS
Umphrey's McGee



LESTER ESTELLE
Kelly Clarkson/Sessions



LINA ANDERBERG
Independent



LOUIE PALMER
Independent



SAM LOEFFLER
Chevelle



SERGIO MELO
The Voice Brazil



SHANE GAALAAS
Cosmosquad



SHANNON FORREST
Sessions



TARON LOCKETT
Cory Henry And The Funk Apostles



MARCUS FINNIE
Independent



MARVIN "SMITTY" SMITH
Independent



MATT ABTS
Gov't Mule



MATT HALPERN
Periphery



MATT MCGUIRE
The Chainsmokers



TAVARIUS JOHNSON
Jon McReynolds / Lalah Hathaway



TERENCE HIGGINS
Tab Benoit / Ani DiFranco



TODD SUCHERMAN
Styx



TONY PALERMO
Papa Roach



TOSH PETERSON
The Kid LAROI, JXDN



MICHAEL CARTELLONE
Lynyrd Skynyrd



MICHEL'E BAPTISTE
Lizzo



MIKE MANGINI
Dream Theater



MIKE MILEY
Rival Sons



MIKE WENGTEN
Disturbed



TRACY BROUSSARD
Blake Shelton



TRAVIS ORBIN
Darkest Hour



TROY WRIGHT
Independent



WILL HUNT
Evanescence



WILL KENNEDY
Yellowjackets / Jazz Legend

COLOR & CONFIGURATION CHART

P Premium Finish **C** Custom Finish

REFERENCE ONE THE REFERENCE LEGACY... UNLEASHED.

PAGES 24 - 25

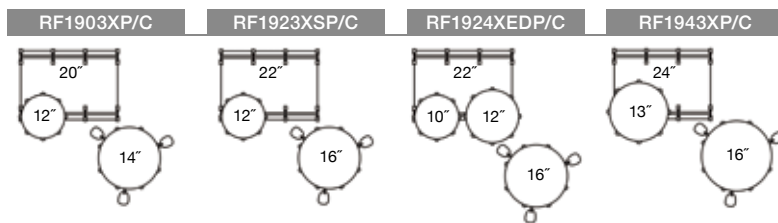

MASTERS MAPLE GUM THE EVOLUTION OF PREMIUM STUDIO TONE.

PAGES 24 - 25

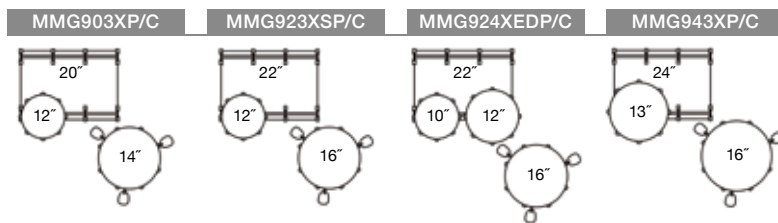

MASTERS MAPLE SONICALLY CENTERED, ARTICULATE, AND POWERFUL.

PAGES 24 - 25

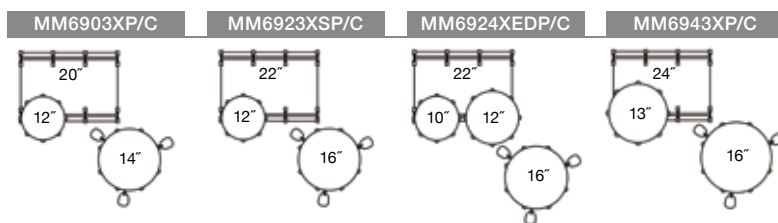

MASTERS MAPLE PURE BRIDGING THE GAP BETWEEN STUDIO AND STAGE.

PAGES 24 - 25

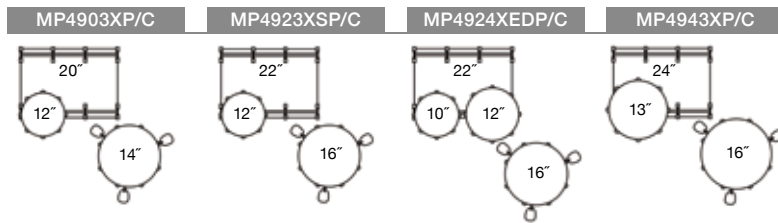

COLOR & CONFIGURATION CHART

PROFESSIONAL SERIES AN UPDATED, UPGRADED, PREMIUM GIGGING POWERHOUSE.

PAGES 24 - 25

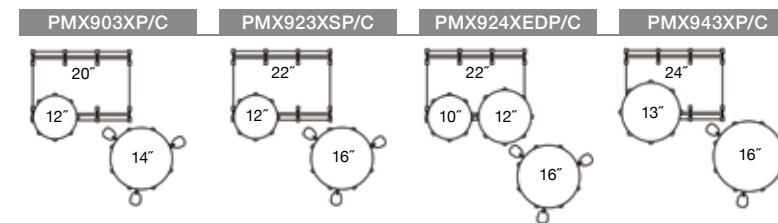

SESSION STUDIO SELECT AN ALL MAPLE DRUM SHELL FIT FOR THE MASTERS LEGACY.

PAGES 24 - 25

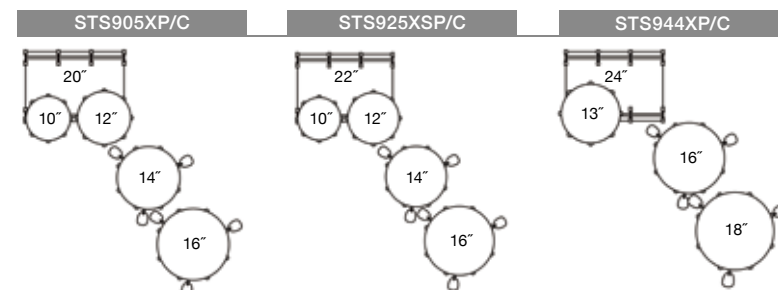

PRESIDENT SERIES DELUXE A MODERN REVIVAL OF THE DARKLY UNIQUE LAUAN SOUND.

PAGES 24 - 25

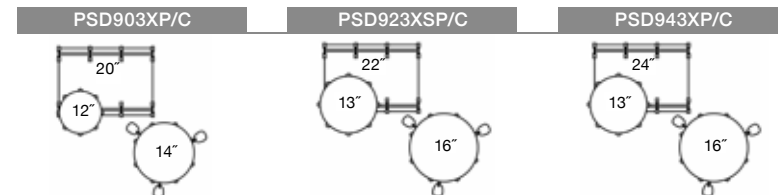

COLOR & CONFIGURATION CHART

CRYSTAL BEAT THE ORIGINAL SEAMLESS ACRYLIC DRUM SHELL.

PAGES 24 - 25



#730 Ultra Clear

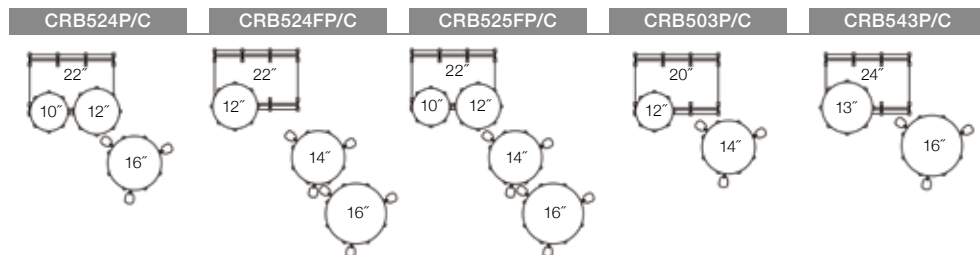

DECADE MAPLE A DRUM KIT 10 YEARS IN THE MAKING.

PAGES 24 - 25



#208 Blue Mirage #261 Gloss Deep Red Burst



#262 Satin Black Burst #849 Rose Mirage

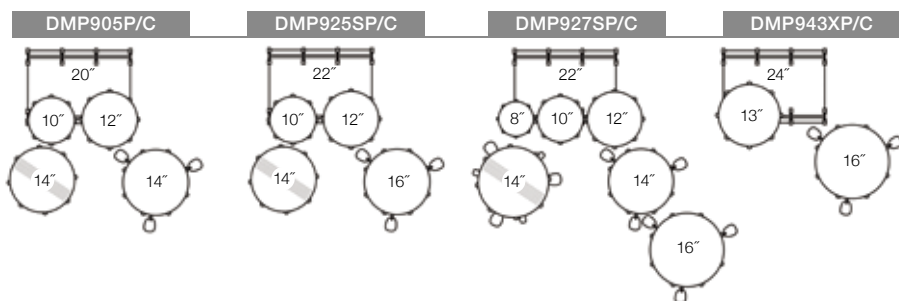

EXPORT THE BEST SELLING DRUM SET OF ALL TIME.

PAGES 24 - 25



#21 Smokey Chrome #31 Jet Black #33 Pure White



#717 High Voltage Blue #760 Burgundy

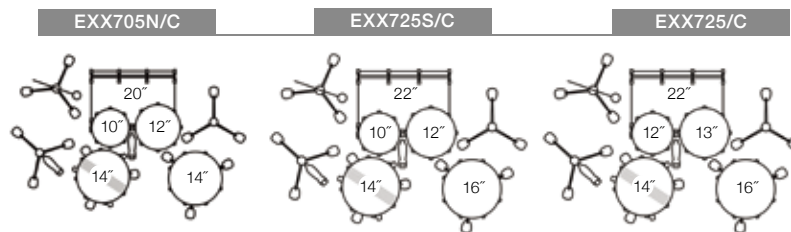

INCLUDES HWP830 HARDWARE PACK

COLOR & CONFIGURATION CHART

ROADSHOW IT'S YOUR TIME TO PLAY, START THE RIGHT WAY.

PAGES 24 - 25



#31 Jet Black #33 Pure White #91 Red Wine



#703 Aqua Blue Glitter #706 Charcoal Metallic #707 Bronze Metallic



#749 Burnt Orange Sparkle

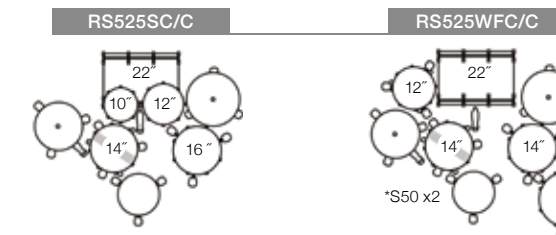
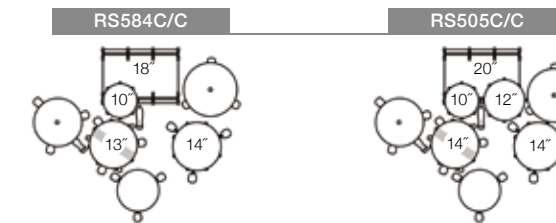

*S50 x2

INCLUDES CH50/H50/S50/P50/D50/16" CRASH/14" HI-HATS, STICK BAG, STICKS

MIDTOWN BIG GIG, SMALL RIG, HUGE SOUND.

PAGES 24 - 25



#33 Pure White #701 Black Gold Sparkle #704 Black Cherry Glitter

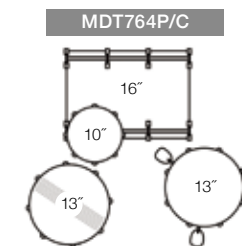

ROADSHOW JR. COMPLETE WITH HARDWARE, CYMBALS, AND THRONE FOR DRUMMERS UNDER 8.

PAGES 24 - 25



#31 Jet Black #33 Pure White #708 Grindstone Sparkle

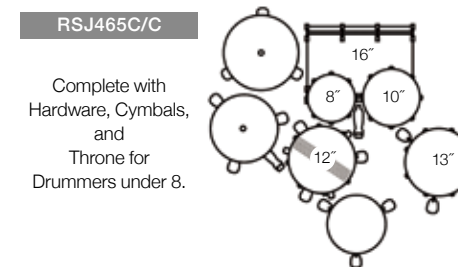

Complete with Hardware, Cymbals, and Throne for Drummers under 8.



THE BEST WARRANTY IN THE INDUSTRY!*

COMMITTED TO THE HIGHEST LEVEL OF CUSTOMER SATISFACTION.

The Pearl Lifetime Warranty is a statement of confidence to our customers to the reliability of Pearl products. Pearl drums, stands and hardware are designed and manufactured to the highest standards in quality, style, appearance and playing performance. This lifetime warranty reflects a tradition of excellence and a commitment to superior engineering and craftsmanship dedicated to you, the drummer. The Pearl lifetime warranty is our pledge to you that we will proudly stand behind our product for as long as you own it. **BUY IT ONCE, PLAY IT FOR LIFE.**

- Drum Set/Concert wood and metal shells for the Lifetime of the Original Owner.
- Foot pedals, hi-hat stands, cymbals stands, boom cymbal stands, snare drum stands, throne bases, floor-standing tom stands, floor-standing cymbal/ tom stands, concert stands, racks and rack accessories, cymbal holders and multi-clamps for the Lifetime of the Original Owner.
- Drum Set claws, tension rods, swivel nuts, spurs, tom brackets, tom holders, strainers, and nuts and bolts for the Lifetime of the Original Owner.
- Rotationally molded cases for the Lifetime of the Original Owner.
- The Lifetime Warranty applies to the aforementioned Pearl products purchased from June 15, 2009.
- * This Lifetime Warranty is valid only in the United States and excludes the Crystal Beat and Roadshow Series. Some exceptions apply.



SPECIAL ORDER LACQUER FINISHES

[PREMIUM]



#100 Wine Red



#102 Natural Maple



#103 Piano Black



#109 Arctic White



#119 Matte Black



#142 Rootbeer Fade



#152 Antique Gold



#155 Scarlet Fade



#342 Vintage Tobacco Burst



#355 Antique Walnut



#831 Matte Olive Burst



#844 Satin Rose Gold



#859 Putty Grey



#886 Deep Redburst



#887 Natural Cherry

[CUSTOM]



#195 Crystal Rain



#198 Shimmer of OZ



#376 Ultra Blue Fade



#377 Scarlet Sparkle Burst



#393 Purple Craze II



#824 Satin Charred Oak



#836 Red Burst Stripe



#854 White Ice Swirl



#855 Black Oyster Swirl



#856 Red Oyster Swirl



#857 Sunburst Redstripe



#858 Kobalt Blue Fade Metallic



#885 Cherry Amber Fade

PEARL CORPORATION

Corporate Headquarters

549 Metroplex Dr., P.O. Box 111240 Nashville, TN 37211-3140 | (615) 833-4477 FAX (615) 833-6242

WWW.PEARLDRUM.COM



pearl_drums



PearlDrumCorp



PearlDrumsUS



PearlDrumCorp



PearlDrummersGroup.com